

4,194,304 WORD X 4 BIT DYNAMIC RAM

Description

The TC5117400BSJ/BST is the new generation dynamic RAM organized 4,194,304 word by 4 bits. The TC5117400BSJ/BST utilizes Toshiba's CMOS silicon gate process technology as well as advanced circuit techniques to provide wide operating margins, both internally and to the system user. Multiplexed address inputs permit the TC5117400BSJ/BST to be packaged in a 26/24 pin plastic SOJ (300mil), and 26/24 pin plastic TSOP (300mil). The package size provides high system bit densities and is compatible with widely available automated testing and insertion equipment. System oriented features include single power supply of $5V \pm 10\%$ tolerance, direct interfacing capability with high performance logic families such as Schottky TTL.

Features

- 4,194,304 word by 4 bit organization
- Fast access time and cycle time
- Single power supply of $5V \pm 10\%$ with a built-in V_{BB} generator
- Low Power
 - 605mW MAX. Operating (TC5117400BSJ/BST-60)
 - 523mW MAX. Operating (TC5117400BSJ/BST-70)
 - 5.5mW MAX. Standby
- Outputs unlatched at cycle end allows two-dimensional chip selection
- Common I/O capability using "EARLY WRITE" operation
- Read-Modify-Write, \overline{CAS} before \overline{RAS} refresh, \overline{RAS} -only refresh, Hidden refresh, Fast Page Mode and Test Mode capability
- All inputs and outputs TTL compatible
- 2048 refresh cycles/32ms
- Package TC5117400BSJ: SOJ26-P-300C
TC5117400BST: TSOP26-P-300D

Key Parameters

ITEM	TC5117400BSJ/BST	
	-60	-70
t_{RAC} \overline{RAS} Access Time	60ns	70ns
t_{AA} Column Address Access Time	30ns	35ns
t_{CAC} \overline{CAS} Access Time	15ns	20ns
t_{RC} Cycle Time	110ns	130ns
t_{PC} Fast Page Mode Cycle Time	40ns	45ns

1. This technical data may be controlled under U.S. Export Administration Regulations and may be subject to the approval of the U.S. Department of Commerce prior to export. Any export or re-export, directly or indirectly, in contravention of the U.S. Export Administration Regulations is strictly prohibited.

2. LIFE SUPPORT POLICY

Toshiba products described in this document are not authorized for use as critical components in life support systems without the written consent of the appropriate officer of Toshiba America, Inc. Life support systems are either systems intended for surgical implant in the body or systems which sustain life.

A critical component in any component of a life support system whose failure to perform may cause a malfunction of the life support system, or may affect its safety or effectiveness.

3. The information in this document has been carefully checked and is believed to be reliable; however no responsibility can be assumed for inaccuracies that may not have been caught. All information in this data book is subject to change without prior notice. Furthermore, Toshiba cannot assume responsibility for the use of any license under the patent rights of Toshiba or any third parties.

Pin Name

A0 ~ A10	Address Inputs
$\overline{\text{RAS}}$	Row Address Strobe
$\overline{\text{CAS}}$	Column Address Strobe
$\overline{\text{WE}}$	Write Enable
$\overline{\text{OE}}$	Output Enable
I/O1~I/O4	Data Input/Output
V _{CC}	Power (+5V)
V _{SS}	Ground

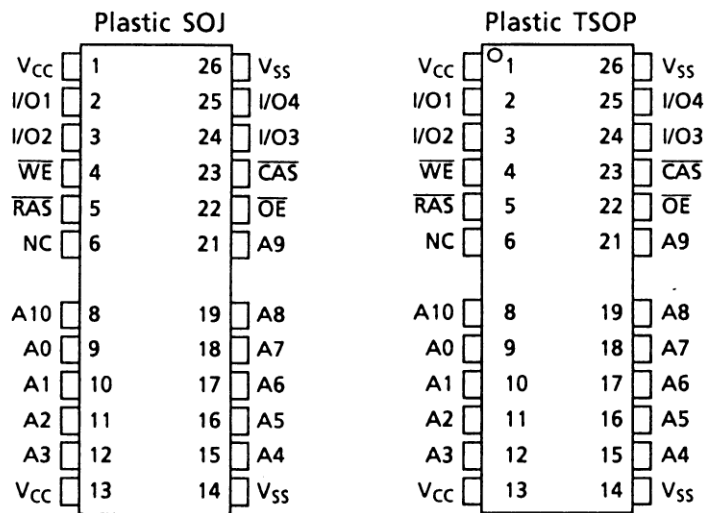
Pin Connection (Top View)

Block Diagram

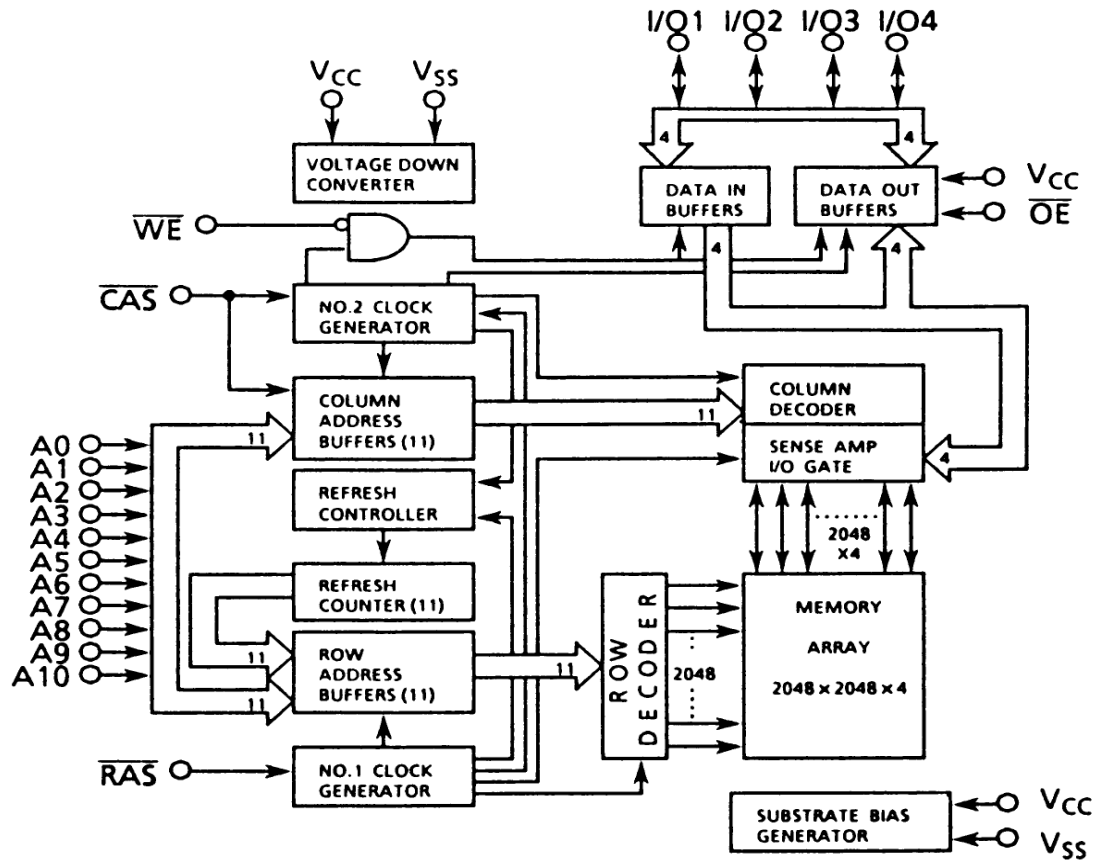

Absolute Maximum Ratings

ITEM	SYMBOL	RATING	UNIT	NOTE
Input Voltage	V_{IN}	-0.5~ $V_{CC}+0.5$	V	1
Output Voltage	V_{OUT}	-0.5~ $V_{CC}+0.5$	V	1
Power Supply Voltage	V_{CC}	-0.5~7.0	V	1
Operating Temperature	T_{OPR}	0~70	°C	1
Storage Temperature	T_{STG}	-55~150	°C	1
Soldering Temperature (10s)	T_{SOLDER}	260	°C	1
Power Dissipation	P_D	900	mW	1
Short Circuit Output Current	I_{OUT}	50	mA	1

Recommended DC Operating Conditions (Ta = 0 ~ 70°C)

SYMBOL	PARAMETER	MIN.	TYP.	MAX.	UNIT	NOTE
V _{CC}	Power Supply Voltage	4.5	5.0	5.5	V	2
V _{IH}	Input High Voltage	2.4	-	V _{CC} + 0.5*	V	2
V _{IL}	Input Low Voltage	-0.5**	-	0.8	V	2

*V_{CC} + 2.0V at pulse width ≤ 20ns (pulse width is measured at V_{CC}).**-2.0V at pulse width ≤ 20ns (pulse width is measured at V_{SS}).DC Electrical Characteristics (V_{CC} = 5V ± 10%, Ta = 0 ~ 70°C)

SYMBOL	PARAMETER	MIN	MAX	UNIT	NOTE	
I _{CC1}	OPERATING CURRENT Average Power Supply Operating Current ($\overline{\text{RAS}}$, $\overline{\text{CAS}}$, Address Cycling: t _{RC} =t _{RC} MIN)	TC5117400BSJ/BST-60	-	110	mA	3,4 5
		TC5117400BSJ/BST-70	-	95		
I _{CC2}	STANDBY CURRENT Power Supply Standby Current ($\overline{\text{RAS}}=\overline{\text{CAS}}=V_{\text{IH}}$)		-	2	mA	
I _{CC3}	RAS ONLY REFRESH CURRENT Average Power Supply Current, RAS Only Mode (RAS Cycling, $\overline{\text{CAS}}=V_{\text{IH}}$; t _{RC} =t _{RC} MIN.)	TC5117400BSJ/BST-60	-	110	mA	3, 5
		TC5117400BSJ/BST-70	-	95		
I _{CC4}	FAST PAGE MODE CURRENT Average Power Supply Current, Fast Page Mode ($\overline{\text{RAS}}=V_{\text{IL}}$, $\overline{\text{CAS}}$, Address Cycling: t _{PC} =t _{PC} MIN.)	TC5117400BSJ/BST-60	-	70	mA	3,4 5
		TC5117400BSJ/BST-70	-	60		
I _{CC5}	STANDBY CURRENT Power Supply Standby Current ($\overline{\text{RAS}}=\overline{\text{CAS}}=V_{\text{CC}}-0.2\text{V}$)		-	1	mA	
I _{CC6}	CAS BEFORE RAS REFRESH CURRENT Average Power Supply Current, $\overline{\text{CAS}}$ Before $\overline{\text{RAS}}$ Mode (RAS, CAS, Cycling: t _{RC} =t _{RC} MIN.)	TC5117400BSJ/BST-60	-	110	mA	3, 5
		TC5117400BSJ/BST70	-	95		
I _{I(L)}	INPUT LEAKAGE CURRENT Input Leakage Current, any input (0V < V _{IN} < V _{CC} , All Other Pins Not Under Test=0V)		-10	10	μA	
I _{O(L)}	OUTPUT LEAKAGE CURRENT (D _{OUT} is disabled, (0V ≤ V _{OUT} < V _{CC}))		-10	10	μA	
V _{OH}	OUTPUT LEVEL Output "H" Level Voltage (I _{OUT} =-5mA)		2.4	-	V	
V _{OL}	OUTPUT LEVEL Output "L" Level Voltage (I _{OUT} =4.2mA)		-	0.4	V	

Electrical Characteristics and Recommended AC Operating Conditions ($V_{CC} = 5V \pm 10\%$, $T_a = 0\sim 70^{\circ}C$) (Notes 6,7,8)

SYMBOL	PARAMETER	TC5117400BSJ/BST				UNIT	NOTES
		-60		-70			
		MIN	MAX.	MIN	MAX		
t_{RC}	Random Read or Write Cycle Time	110	-	130	-	ns	
t_{RMW}	Read-Modify-Write Cycle	155	-	180	-	ns	
t_{PC}	Fast Page Mode Cycle Time	40	-	45	-	ns	
t_{PRMW}	Fast Page Mode Read-Modify-Write Cycle Time	85	-	95	-	ns	
t_{RAC}	Access Time from \overline{RAS}	-	60	-	70	ns	9,14,15
t_{CAC}	Access Time from \overline{CAS}	-	15	-	20	ns	9,14
t_{AA}	Access Time from Column Address	-	30	-	35	ns	9,15
t_{CPA}	Access Time from \overline{CAS} Precharge	-	35	-	40	-	9
t_{CLZ}	\overline{CAS} to Output in Low-Z	0	-	0	-	ns	9
t_{OFF}	Output Buffer Turn-off Delay	0	15	0	15	ns	10
t_T	Transition Time (Rise and Fall)	3	50	3	50	ns	8
t_{RP}	\overline{RAS} Precharge Time	40	-	50	-	ns	
t_{RAS}	\overline{RAS} Pulse Width	60	10,000	70	10,000	ns	
t_{RASP}	\overline{RAS} Pulse Width (Fast Page Mode)	60	200,000	70	200,000	ns	
t_{RSH}	\overline{RAS} Hold Time	15	-	20	-	ns	
t_{RHCP}	\overline{RAS} Hold Time from \overline{CAS} Precharge (Fast Page Mode)	35	-	40	-	ns	
t_{CSH}	\overline{CAS} Hold Time	60	-	70	-	ns	
t_{CAS}	\overline{CAS} Pulse Width	15	10,000	20	10,000	ns	
t_{RCD}	\overline{RAS} to \overline{CAS} Delay Time	20	45	20	50	ns	14
t_{RAD}	\overline{RAS} to Column Address Delay Time	15	30	15	35	ns	15
t_{CRP}	\overline{CAS} to \overline{RAS} Precharge Time	5	-	5	-	ns	
t_{CP}	\overline{CAS} Precharge Time	10	-	10	-	ns	
t_{ASR}	Row Address Set-Up Time	0	-	0	-	ns	
t_{RAH}	Row Address Hold Time	10	-	10	-	ns	
t_{ASC}	Column Address Set-Up Time	0	-	0	-	ns	
t_{CAH}	Column Address Hold Time	10	-	15	-	ns	
t_{RAL}	Column Address to \overline{RAS} Lead Time	30	-	35	-	ns	
t_{RCS}	Read Command Set-Up Time	0	-	0	-	ns	
t_{RCH}	Read Command Hold Time	0	-	0	-	ns	11
t_{RRH}	Read Command Hold Time referenced to \overline{RAS}	0	-	0	-	ns	11

Electrical Characteristics and Recommended AC Operating Conditions (Cont)

SYMBOL	PARAMETER	TC5117400BSJ/BST				UNIT	NOTES
		-60		-70			
		MIN	MAX.	MIN	MAX		
t_{WCH}	Write Command Hold Time	10	-	15	-	ns	
t_{WP}	Write Command Pulse Width	10	-	15	-	ns	
t_{RWL}	Write Command to \overline{RAS} Lead Time	15	-	20	-	ns	
t_{CWL}	Write Command to \overline{CAS} Lead Time	15	-	20	-	ns	
t_{DS}	Data Set-Up Time	0	-	0	-	ns	12
t_{DH}	Data Hold Time	10	-	15	-	ns	12
t_{REF}	Refresh Period	-	32	-	32	ms	
t_{WCS}	Write Command Set-Up Time	0	-	0	-	ns	13
t_{CWD}	\overline{CAS} to \overline{WE} Delay Time	40	-	45	-	ns	13
t_{RWD}	\overline{RAS} to \overline{WE} Delay Time	85	-	95	-	ns	13
t_{AWD}	Column Address to \overline{WE} Delay Time	55	-	60	-	ns	13
t_{CPWD}	\overline{CAS} Precharge to \overline{WE} Delay Time	60	-	65	-	ns	13
t_{CSR}	\overline{CAS} Set-Up Time (\overline{CAS} before \overline{RAS} Cycle)	5	-	5	-	ns	
t_{CHR}	\overline{CAS} Hold Time (\overline{CAS} before \overline{RAS} Cycle)	10	-	15	-	ns	
t_{RPC}	\overline{RAS} to \overline{CAS} Precharge Time	5	-	5	-	ns	
t_{CPT}	\overline{CAS} Precharge Time (\overline{CAS} before \overline{RAS} Counter Test Cycle)	20	-	30	-	ns	
t_{ROH}	\overline{RAS} Hold Time referenced to \overline{OE}	10	-	10	-	ns	
t_{OEA}	\overline{OE} Access Time	-	15	-	20	ns	
t_{OED}	\overline{OE} to Data Delay	15	-	15	-	ns	
t_{OEZ}	Output buffer turn off Delay Time from \overline{OE}	0	15	0	15	ns	10
t_{OEH}	\overline{OE} Command Hold Time	10	-	15	-	ns	
t_{ODS}	Output Disable Setup Time	0	-	0	-	ns	
t_{WTS}	Write Command Set-up Time (Test Mode In)	10	-	10	-	ns	
t_{WTH}	Write Command Hold Time (Test Mode In)	10	-	10	-	ns	
t_{WRP}	\overline{WE} to \overline{RAS} Precharge Time (\overline{CAS} before \overline{RAS} Cycle)	10	-	10	-	ns	
t_{WRH}	\overline{WE} to \overline{RAS} Hold Time (\overline{CAS} before \overline{RAS} Cycle)	10	-	10	-	ns	

Electrical Characteristics and Recommended AC Operating Conditions in the Test Mode

SYMBOL	PARAMETER	TC5117400BSJ/BST				UNIT	NOTES
		-60		-70			
		MIN	MAX.	MIN	MAX		
t _{RC}	Random Read or Write Cycle Time	115	-	135	-	ns	
t _{PC}	Fast Page Mode Cycle Time	45	-	50	-	ns	
t _{RAC}	Access Time from $\overline{\text{RAS}}$	-	65	-	75	ns	9, 14, 15
t _{CAC}	Access Time from $\overline{\text{CAS}}$	-	20	-	25	ns	9, 14
t _{AA}	Access Time from Column Address	-	35	-	40	ns	9, 15
t _{CPA}	Access Time from $\overline{\text{CAS}}$ Precharge	-	40	-	45	ns	9
t _{RAS}	$\overline{\text{RAS}}$ Pulse Width	65	10,000	75	10,000	ns	
t _{RASP}	$\overline{\text{RAS}}$ Pulse Width (Fast Page Mode)	65	200,000	75	200,000	ns	
t _{RSH}	$\overline{\text{RAS}}$ Hold Time	20	-	25	-	ns	
t _{CSH}	$\overline{\text{CAS}}$ Hold Time	65	-	75	-	ns	
t _{RHCP}	$\overline{\text{CAS}}$ Precharge to $\overline{\text{RAS}}$ Hold	40	-	45	-	ns	
t _{CAS}	$\overline{\text{CAS}}$ Pulse Width	20	10,000	25	10,000	ns	
t _{RAL}	Column Address to $\overline{\text{RAS}}$ Lead Time	35	-	40	-	ns	

Capacitance ($V_{CC} = 5V \pm 10\%$, $f = 1\text{MHz}$, $T_a = 0 \sim 70^\circ\text{C}$)

SYMBOL	PARAMETER	MIN	MAX	UNIT
C _{I1}	Input Capacitance (A0~A10)	-	5	pF
C _{I2}	Input Capacitance ($\overline{\text{RAS}}$, $\overline{\text{CAS}}$, $\overline{\text{WE}}$, $\overline{\text{OE}}$)	-	7	
C _O	Input Capacitance (I/O1~I/O4)	-	7	

Notes:

1. Stresses greater than those listed under "Absolute Maximum Ratings" may cause permanent damage to the device.
2. All voltages are referenced to V_{SS} .
3. I_{CC1} , I_{CC3} , I_{CC4} , I_{CC6} depend on cycle rate.
4. I_{CC1} , I_{CC4} depend on output loading. Specified values are obtained with the output open.
5. Address can be changed one or less while $\overline{RAS}=V_{IL}$. In case of I_{CC4} , it can be changed once or less during a fast page mode cycle (t_{PC}).
6. An initial pause of 200 μ s is required after power-up followed by 8 \overline{RAS} only refresh cycles before proper device operation is achieved. In case of using internal refresh counter, a minimum of 8 \overline{CAS} before \overline{RAS} refresh cycles instead of 8 \overline{RAS} only refresh cycles are required.
7. AC measurements assume $t_T=5$ ns.
8. V_{IH} (min.) and V_{IL} (max.) are reference levels for measuring timing of input signals. Also, transition times are measured between V_{IH} and V_{IL} .
9. Measured with a load equivalent to 2 TTL loads and 100pF.
10. t_{OFF} (max.) defines the time at which the output achieves the open circuit condition and is not referenced to output voltage levels.
11. Either t_{RCH} or t_{RRH} must be satisfied for a read cycle.
12. These parameters are referenced to \overline{CAS} leading edge in early write cycles and to \overline{WE} leading edge in Read-Modify-Write cycles.
13. t_{WCS} , t_{RWD} , t_{CWD} , t_{AWD} and t_{CPWD} are not restrictive operating parameters. They are included in the data sheet as electrical characteristics only. If $t_{WCS} \geq t_{WCS}$ (min.), the cycle is an early write cycle and the data out pin will remain open circuit (high impedance) through the entire cycle; If $t_{RWD} \geq t_{RWD}$ (min.), $t_{CWD} \geq t_{CWD}$ (min.), $t_{AWD} \geq t_{AWD}$ (min.) and $t_{CPWD} \geq t_{CPWD}$ (min.), (Fast Page Mode), the cycle is a Read-Modify-Write cycle and the data out will contain data read from the selected cell: If neither of the above sets of conditions are satisfied, the condition of the data out (at access time) is indeterminate.
14. Operation within the t_{RCD} (max.) limit insures that t_{RAC} can be met. t_{RCD} (max.) is specified as a reference point only: If t_{RCD} is greater than the specified t_{RCD} (max.) limit, then access time is controlled by t_{CAC} .
15. Operation within the t_{RAD} (max.) limit insures that t_{RAC} (max.) can be met. t_{RAD} (max.) is specified as a reference point only: If t_{RAD} is greater than the specified t_{RAD} (max.) limit, then access time is controlled by t_{AA} .

Timing Waveforms

Read Cycle

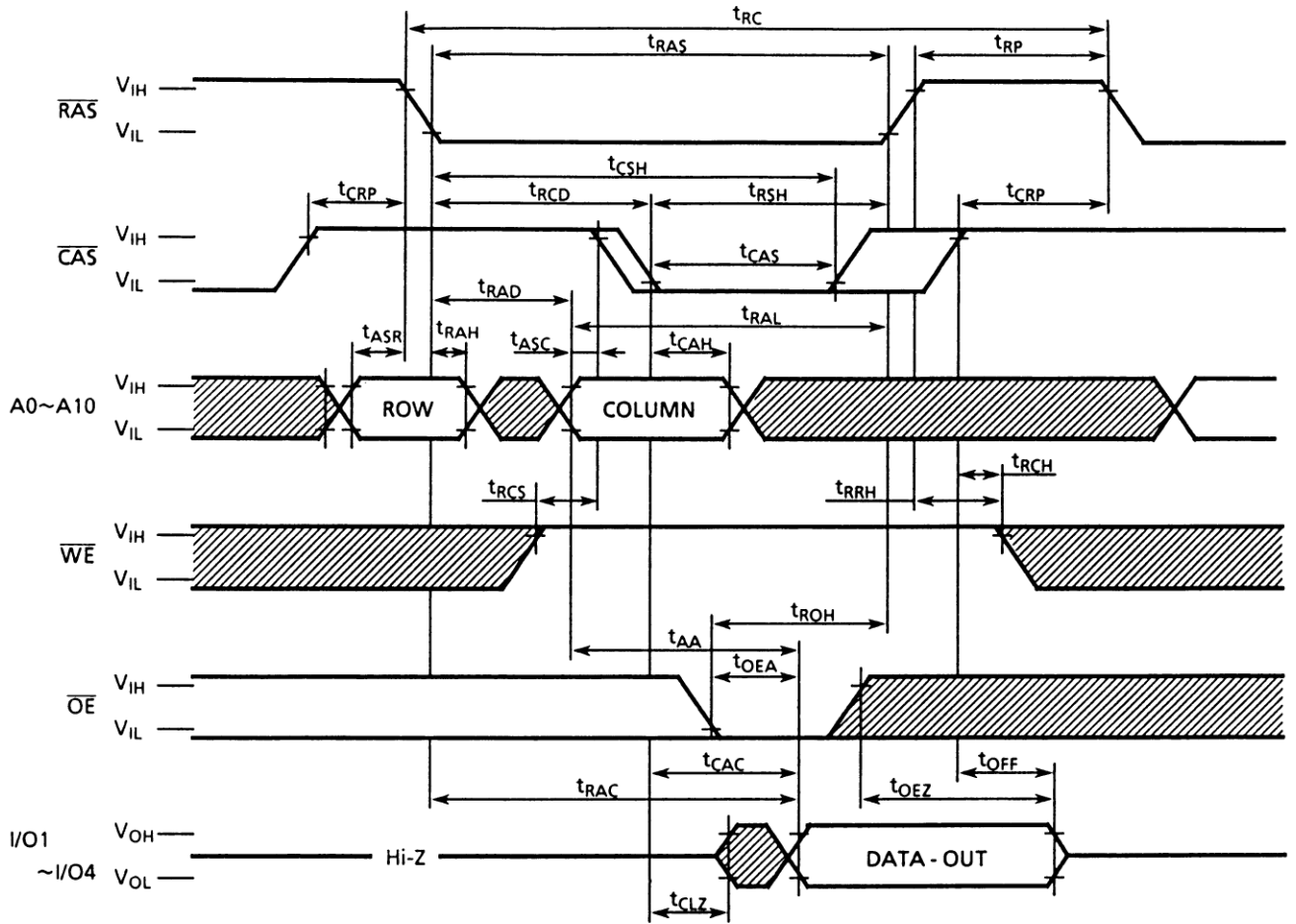

Note: $D_{IN} = \text{Hi-Z}$

▨ : "H" or "L"

Write Cycle (Early Write)

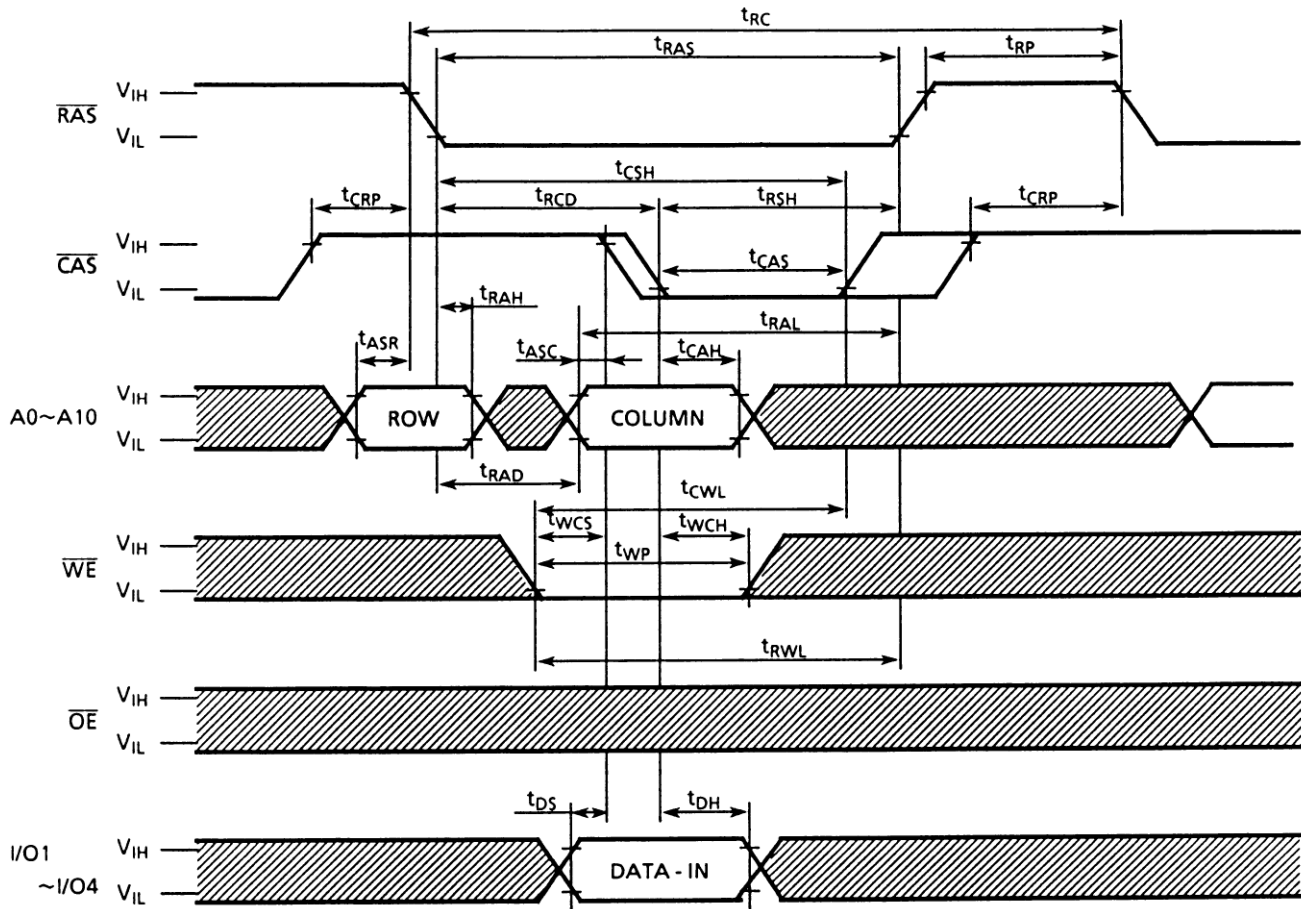

Note: D_{OUT} = Hi-Z

▨ : "H" or "L"

Write Cycle (\overline{OE} Controlled Write)

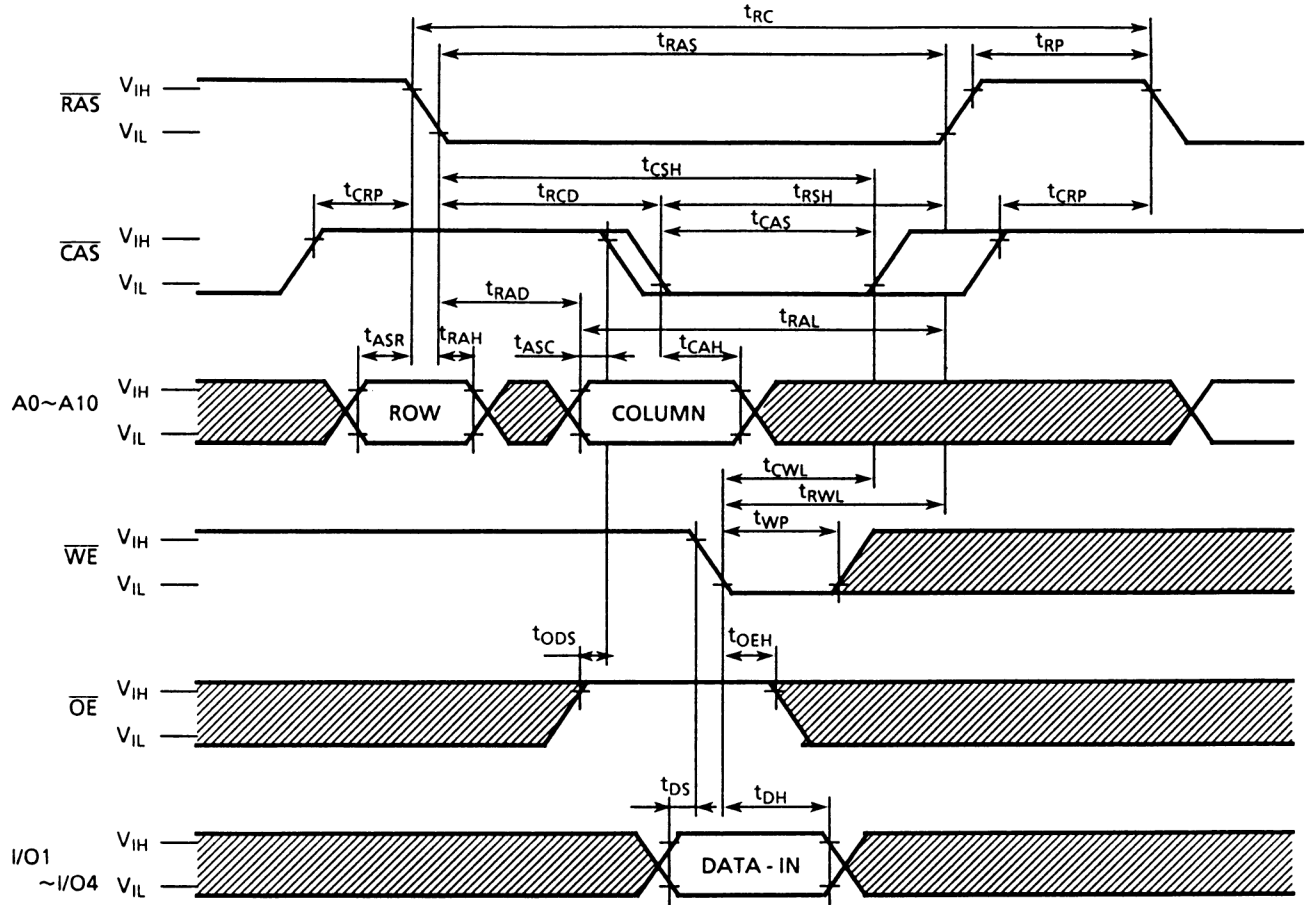

Note: $D_{OUT} = \text{Hi-Z}$

▨ : "H" or "L"

Read-Modify-Write Cycle

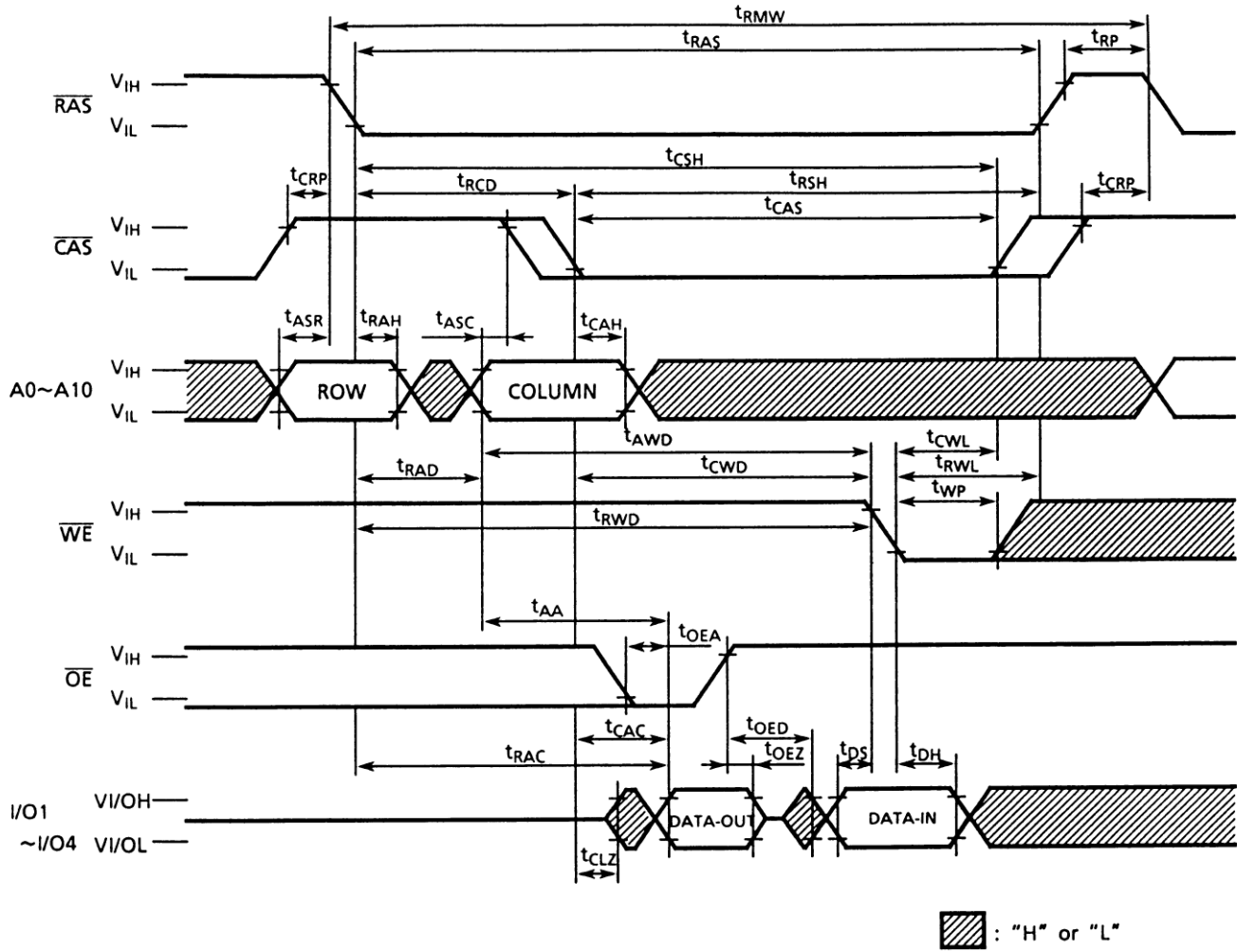

Fast Page Mode Read Cycle

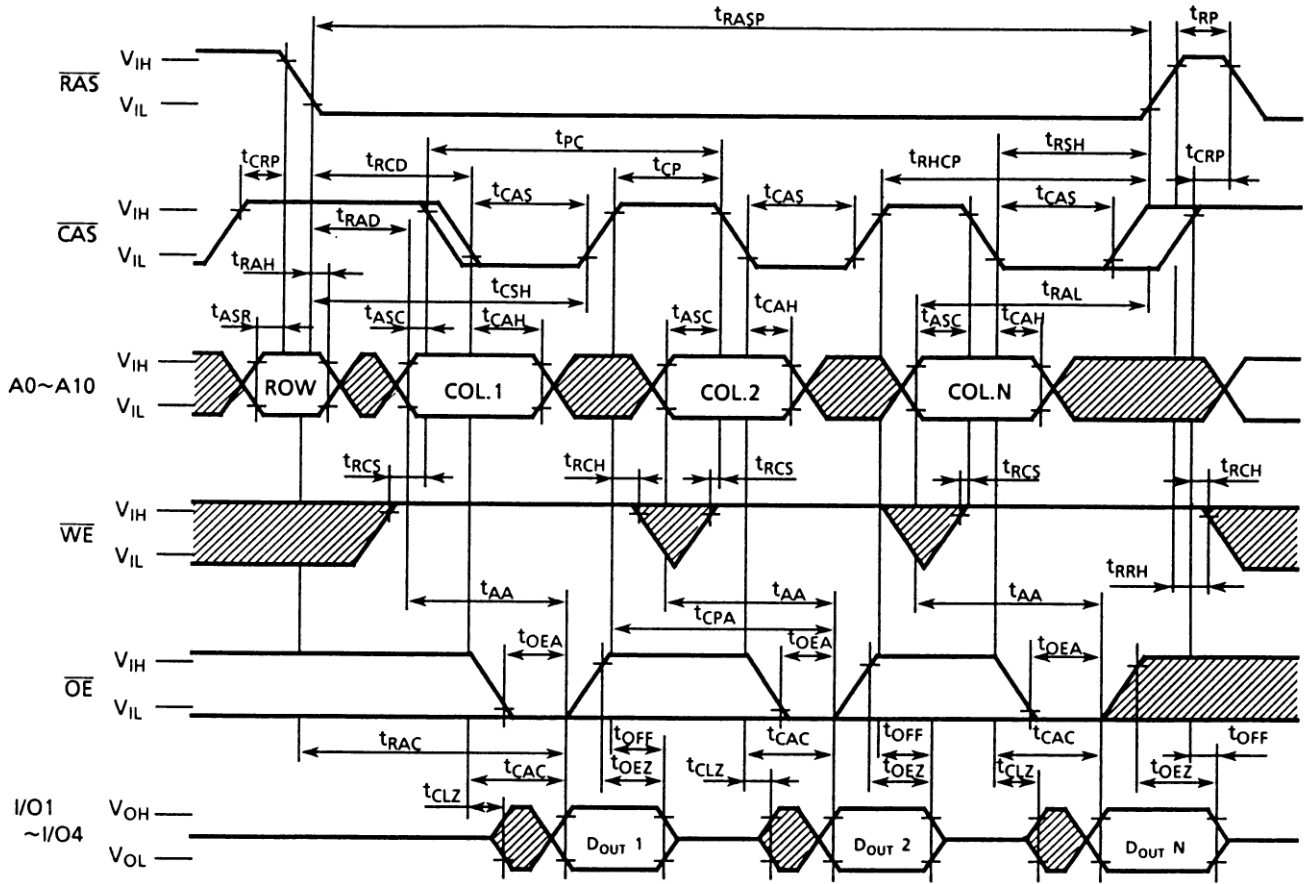

Note: $D_{IN} = Hi-Z$

▨ : "H" or "L"

Fast Page Mode Write Cycle (Early Write)

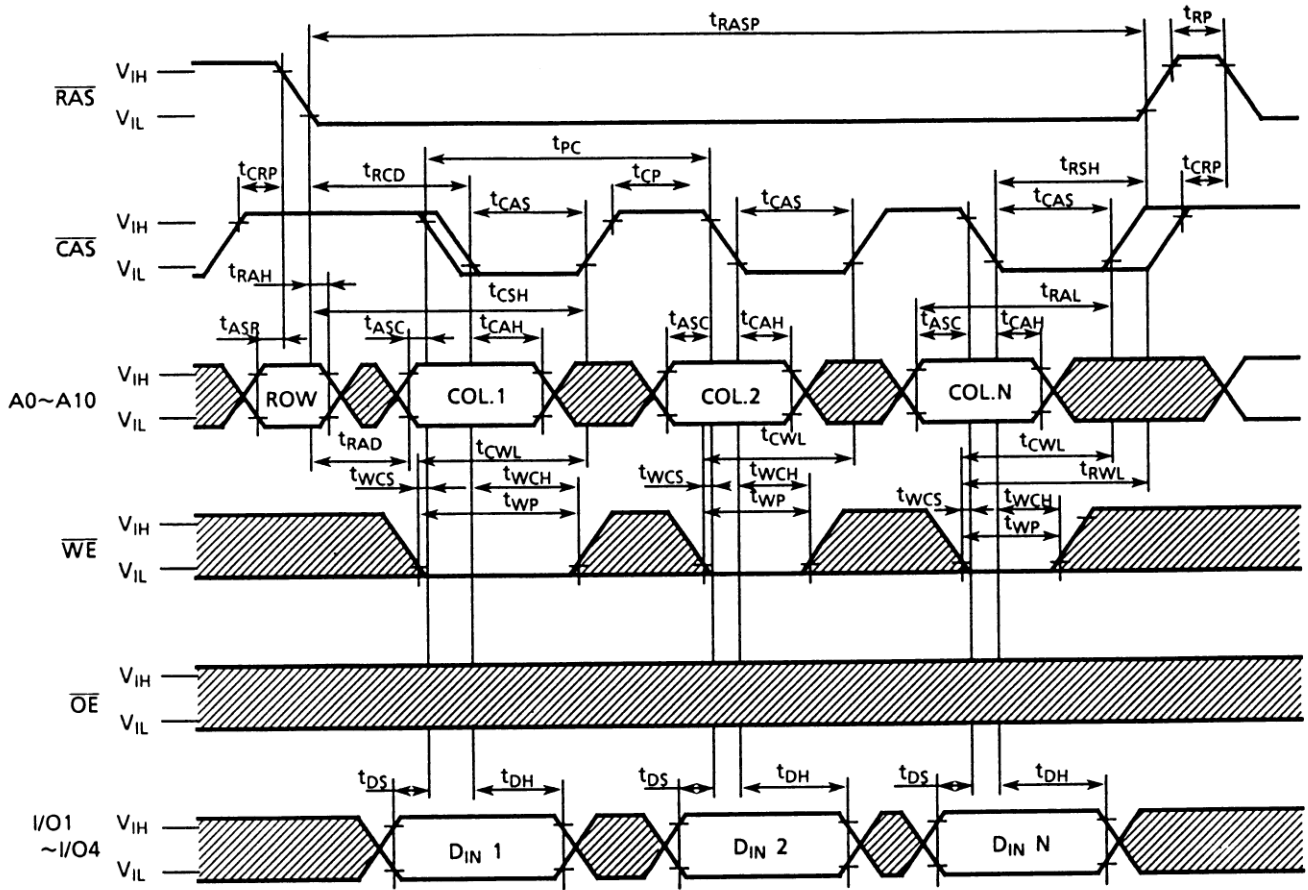

Note: D_{OUT} = Hi-Z

▨ : "H" or "L"

Fast Page Mode Read-Modify-Write Cycle

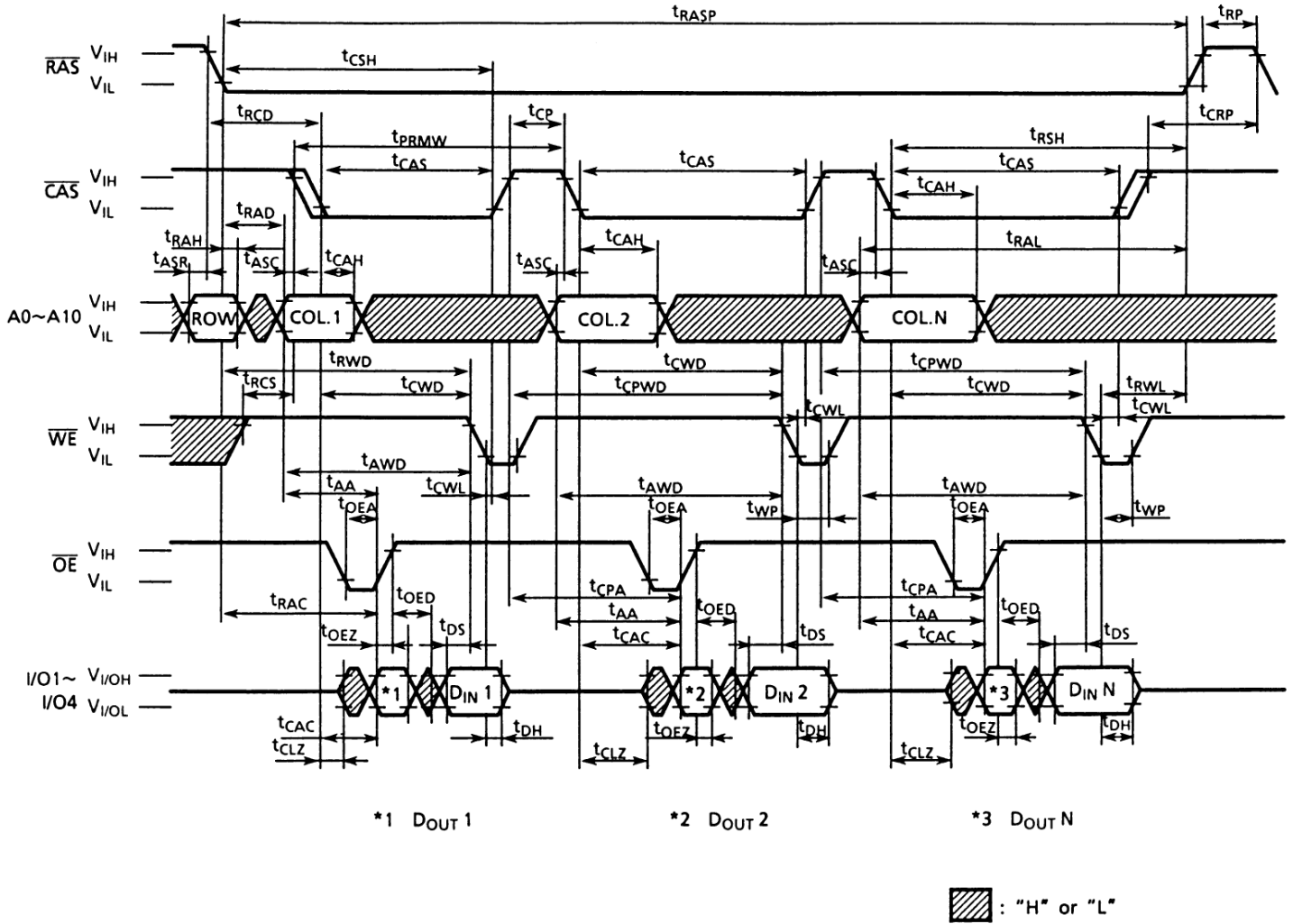

RAS Only Refresh Cycle

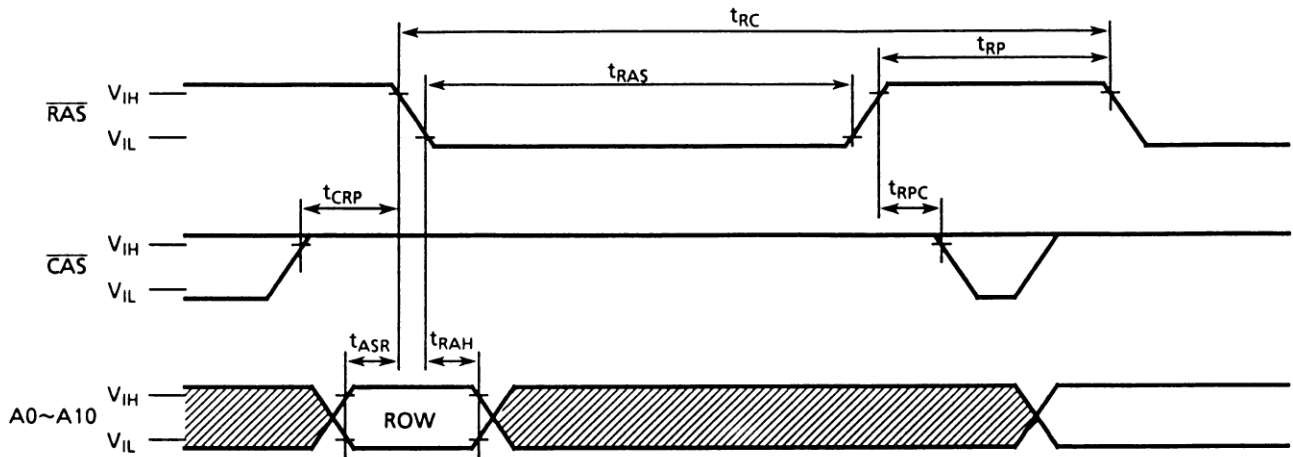

Note: D_{IN} , $\overline{\text{WE}}$, $\overline{\text{OE}} = \text{"H"}$ or "L"

: "H" or "L"

CAS Before RAS Refresh Cycle

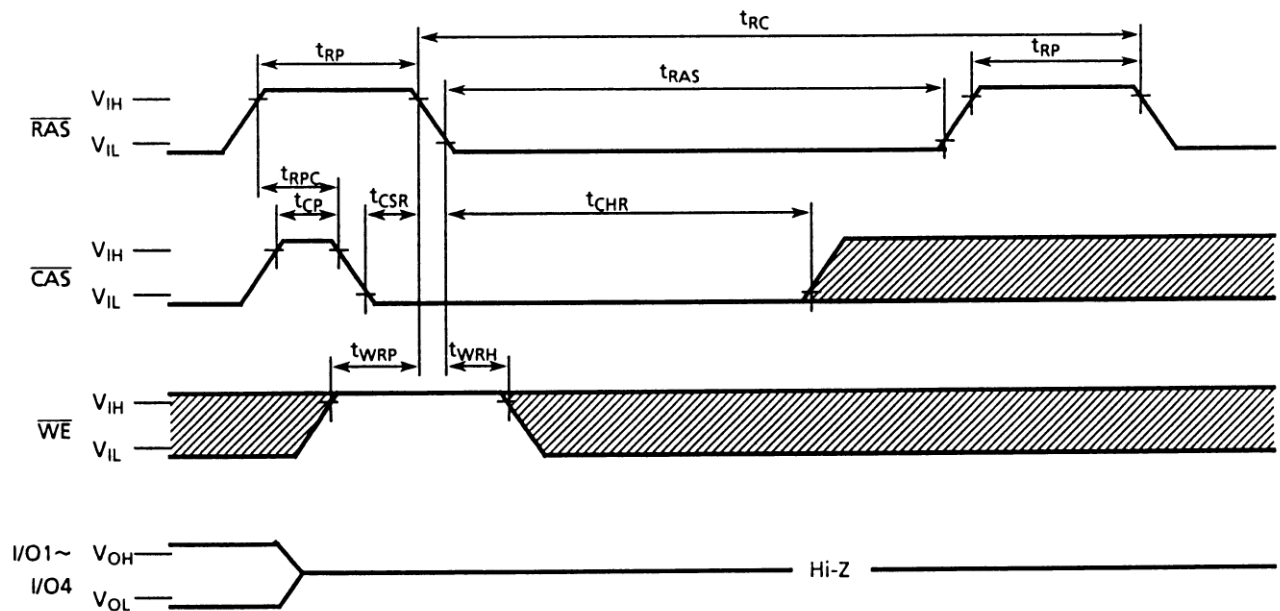

Note: D_{IN} , $\overline{\text{OE}}$, $\text{A0} \sim \text{A10} = \text{"H"}$ or "L"

: "H" or "L"

Hidden Refresh Cycle (Read)

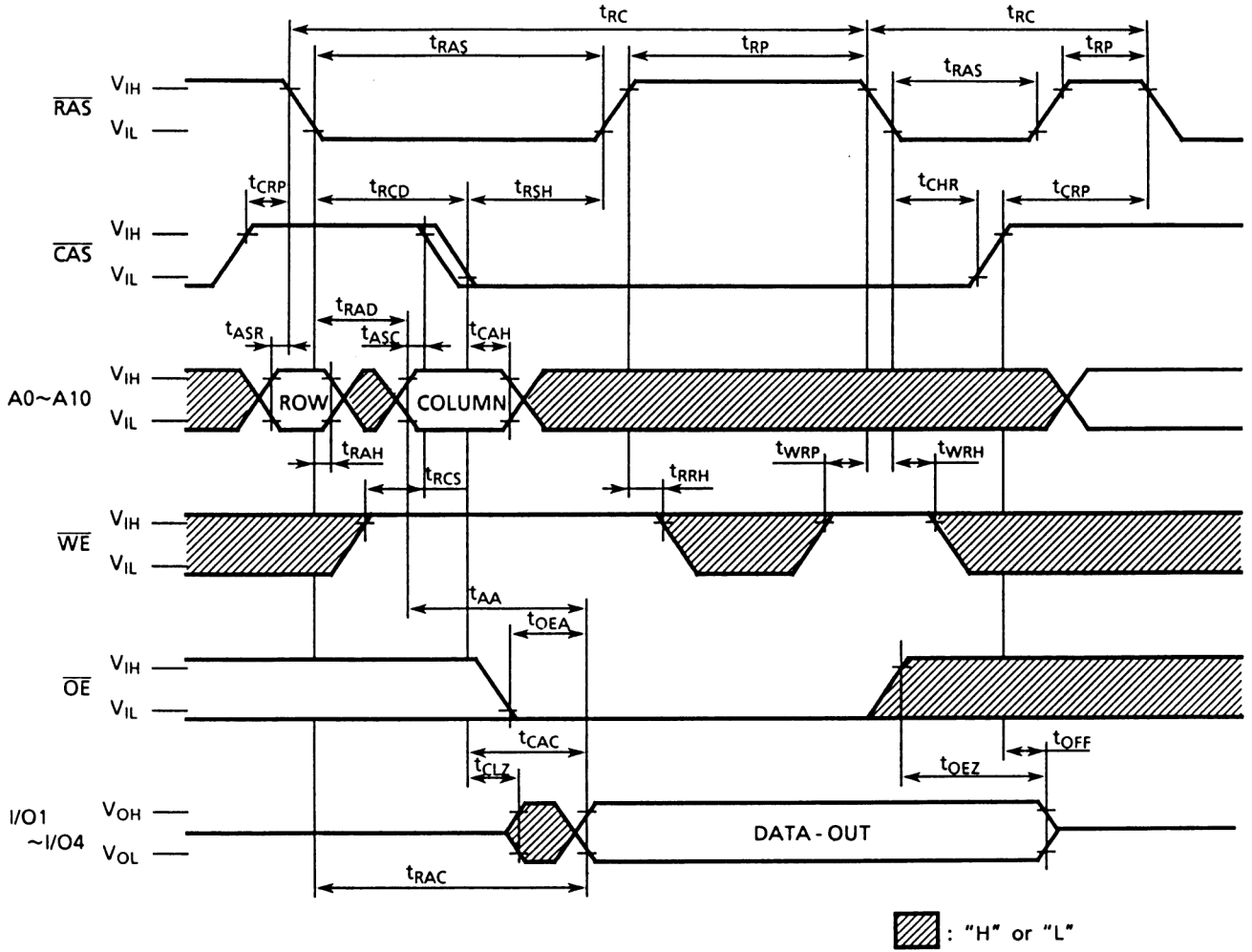

Note: $D_{IN} = \text{Hi-Z}$

Hidden Refresh Cycle (Write)

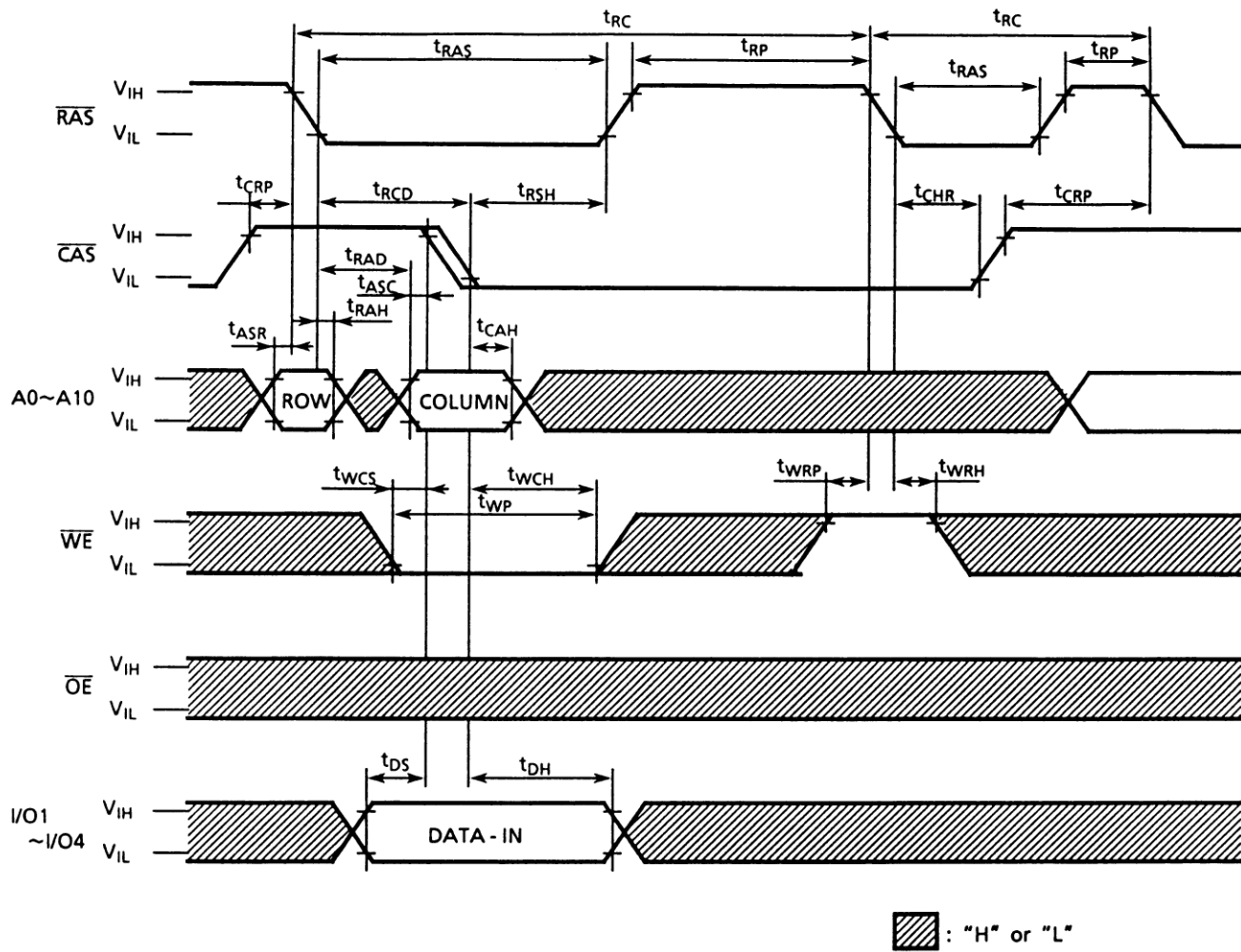

Note: $D_{OUT} = Hi-Z$

Outline Drawings (SOJ26-P-300C)

Unit in mm

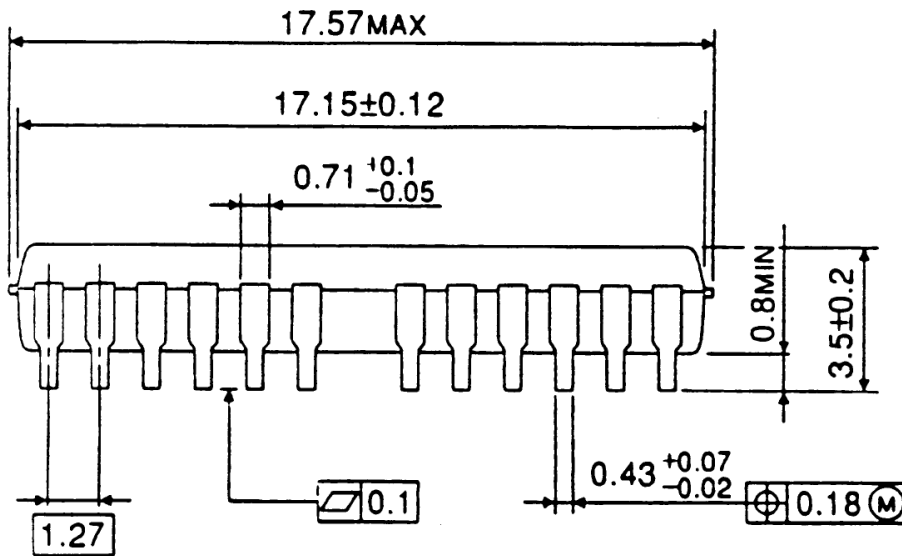
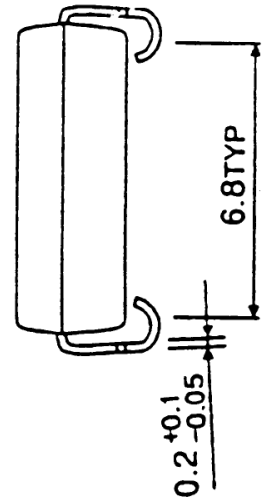
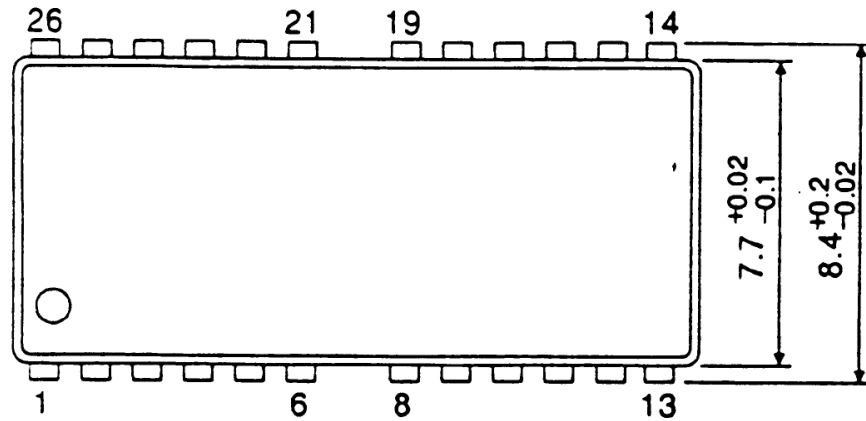

Outline Drawings (TSOP26-P-300D)

Unit in mm

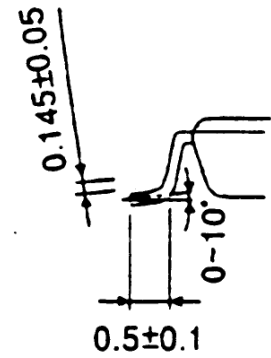
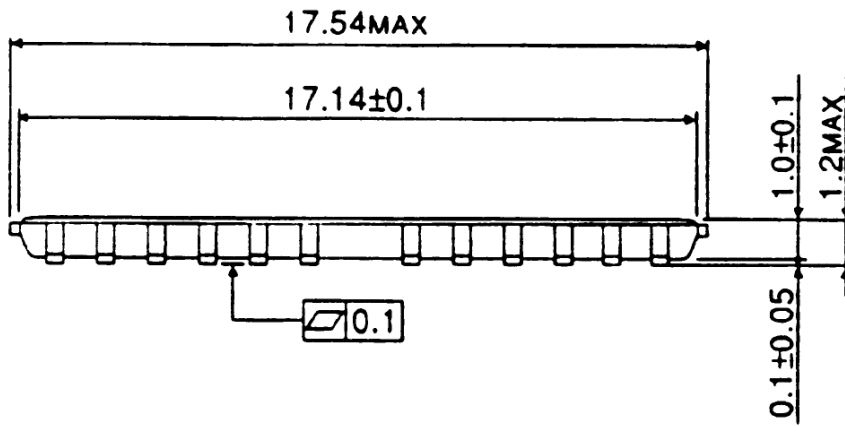
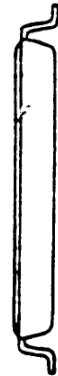
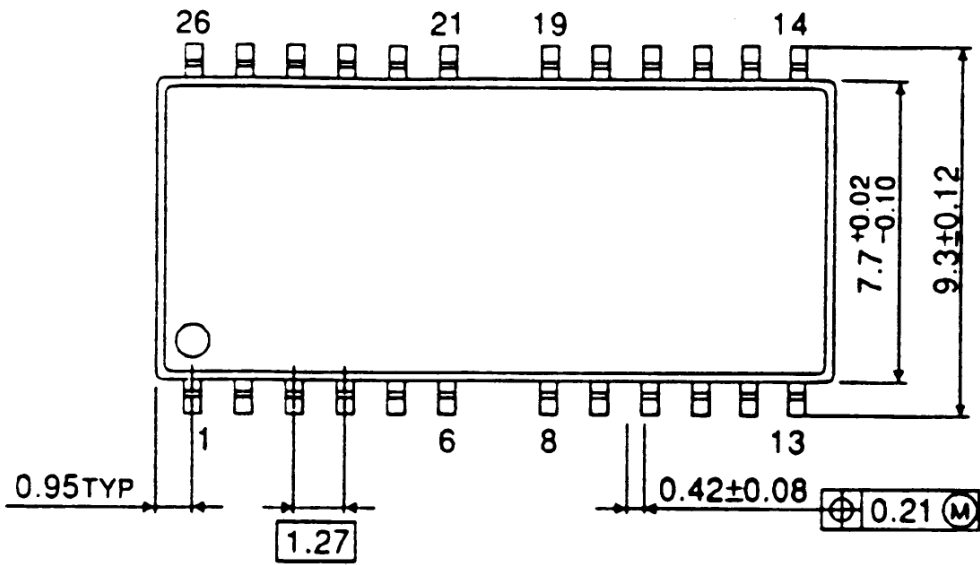

Back to Memory