

## ICs for Communications

ISDN PC Adapter Circuit

IPAC

PSB/F 2115 Version 1.1

IPAC with Capacitive Coupling of S-Interface Receiver

Application Note 02.98

|                                  |                             |  |
|----------------------------------|-----------------------------|--|
| <b>PSB/F 2115</b>                |                             |  |
| <b>Revision History:</b>         |                             | <b>Current Version: 02.98</b>                |
| Previous Version:                |                             | 01.98  |
| Page<br>(in previous<br>Version) | Page<br>(in new<br>Version) | Subjects (major changes since last revision) |
|                                  |                             |  |
|                                  |                             |  |

For questions on technology, delivery and prices please contact the Semiconductor Group Offices in Germany or the Siemens Companies and Representatives worldwide: see our webpage at <http://www.siemens.de/Semiconductor/address/address.htm>.

**Edition 02.98**

**Published by Siemens AG,  
HL TS,  
Balanstraße 73,  
81541 München**

© Siemens AG 1998.  
All Rights Reserved.

**Attention please!**

As far as patents or other rights of third parties are concerned, liability is only assumed for components, not for applications, processes and circuits implemented within components or assemblies.

The information describes the type of component and shall not be considered as assured characteristics.

Terms of delivery and rights to change design reserved.

Due to technical requirements components may contain dangerous substances. For information on the types in question please contact your nearest Siemens Office, Semiconductor Group.

Siemens AG is an approved CECC manufacturer.

**Packing**

Please use the recycling operators known to you. We can also help you – get in touch with your nearest sales office. By agreement we will take packing material back, if it is sorted. You must bear the costs of transport.

For packing material that is returned to us unsorted or which we are not obliged to accept, we shall have to invoice you for any costs incurred.

**Components used in life-support devices or systems must be expressly authorized for such purpose!**

Critical components<sup>1</sup> of the Semiconductor Group of Siemens AG, may only be used in life-support devices or systems<sup>2</sup> with the express written approval of the Semiconductor Group of Siemens AG.

- 1 A critical component is a component used in a life-support device or system whose failure can reasonably be expected to cause the failure of that life-support device or system, or to affect its safety or effectiveness of that device or system.
- 2 Life support devices or systems are intended (a) to be implanted in the human body, or (b) to support and/or maintain and sustain human life. If they fail, it is reasonable to assume that the health of the user may be endangered.

| Table of Contents |  | Page |
|-------------------|--|------|
| 1                 | <b>Overview</b> .....  | 4    |
| 2                 | <b>IPAC with Capacitive Coupling of S-Interface Receiver</b> ..... | 5    |
| 2.1               | S-Interface Description .....                                      | 5    |
| 2.2               | Overvoltage protection .....                                       | 6    |

IOM®, IOM®-1, IOM®-2, SICOFI®, SICOFI®-2, SICOFI®-4, SICOFI®-4µC, SLICOFI®, ARCOFI®, ARCOFI®-BA, ARCOFI®-SP, EPIC®-1, EPIC®-S, ELIC®, IPAT®-2, ITAC®, ISAC®-S, ISAC®-S TE, ISAC®-P, ISAC®-P TE, IDEC®, SICAT®, OCTAT®-P, QUAT®-S are registered trademarks of Siemens AG.

MUSAC™-A, FALC™54, IWE™, SARE™, UTPT™, ASM™, ASP™, DigiTape™ are trademarks of Siemens AG.

Purchase of Siemens I<sup>2</sup>C components conveys a license under the Philips' I<sup>2</sup>C patent to use the components in the I<sup>2</sup>C-system provided the system conforms to the I<sup>2</sup>C specifications defined by Philips. Copyright Philips 1983.

**1 Overview**

This document describes a cost optimized circuit to connect the IPAC to the S-interface. Usually the ISDN devices need external circuits to connect to the S-interface. These standard circuits are consisting of several components which have a big influence to the Bill of Material (BOM).

Using the IPAC PSB 2115 the BOM can be reduced significantly, e.g. it is possible to substitute one transformer by two capacitors and to avoid the choke.

The S-interface solution presented on the following pages is approved with the Stollmann Terminal Adapter (SIPB 72115 TA) by the BZT (Bundesamt für Zulassungen in der Telekommunikation, i.e. German approval lab).

IPAC with Capacitive Coupling of S-Interface Receiver

2 IPAC with Capacitive Coupling of S-Interface Receiver

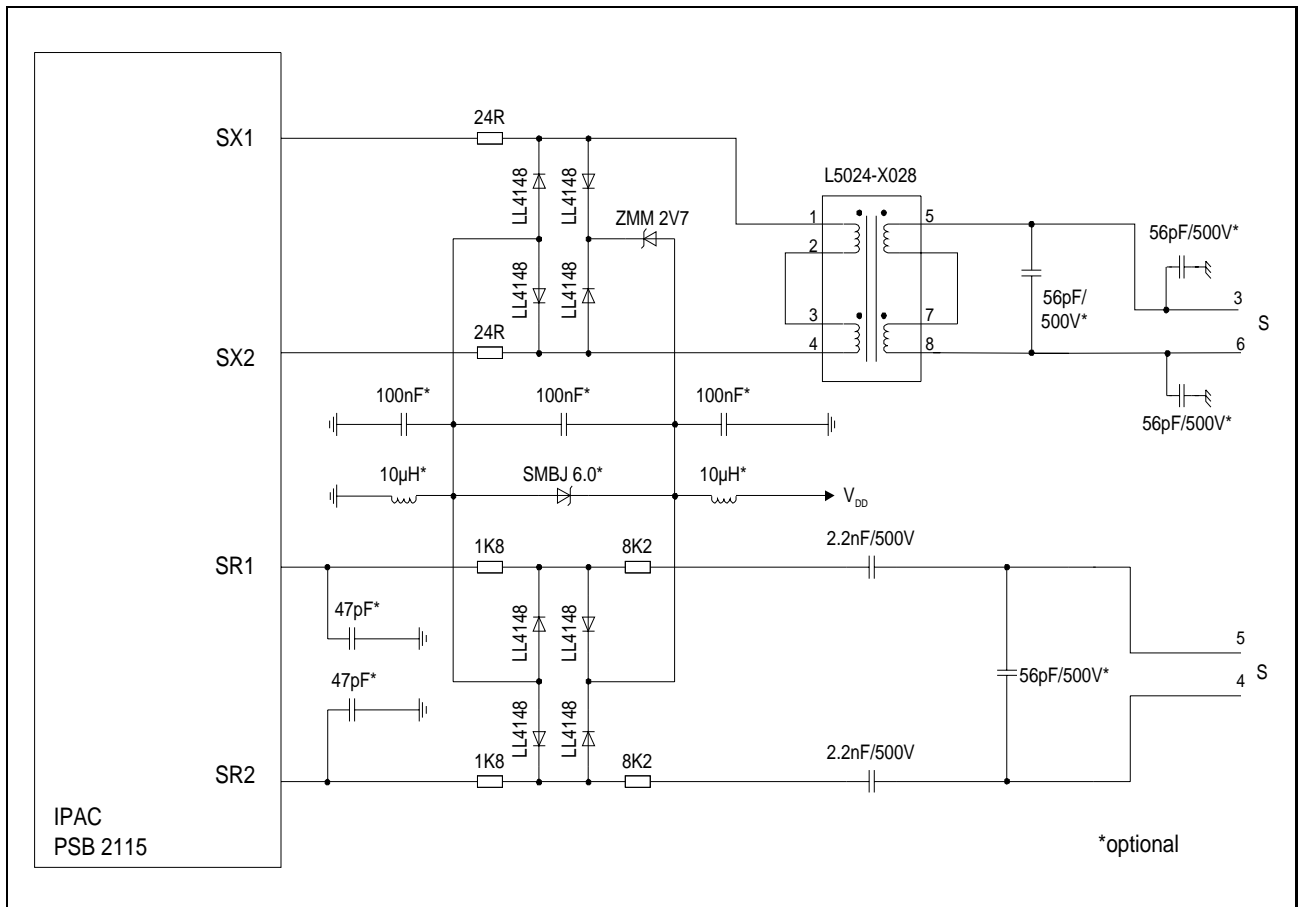

Figure 1

2.1 S-Interface Description

Compared to standard S-interface circuits there is neither a choke in transmit direction nor in receive direction (see Fig. 1). The receive path is connected to the S-interface by two 2.2nF/500V capacitors (available in SMD1206 shape), the transmit path uses a transformer.

The 2.2nF/500V capacitor value at the capacitive interface is chosen due to the turn-on transient current test (phantom power supply at S; ETS 300012).

The capacitors 56pF/500V between the transmit and receive lines suppress push-pull signals with high frequency in both directions. The voltage resistance at the primary side of S needs to be 500V because the IEC801 tests use high voltage bursts.

At the transmit line both 56pF/500V capacitors are connected to the shield to suppress also high frequency coming from the PCB.

Both 47pF capacitors and the resistors at the SR1 and SR2 pins build a low-pass suppressing high frequent noise superimposed to the S-line while testing conformance of receiver sensitivity according to ETS 300012.

---

## IPAC with Capacitive Coupling of S-Interface Receiver

GND and VCC could be superimposed by HF digital noise and therefore influence the layer 1 with high frequency. This frequency will be coupled via the stray capacitance of the diodes to the S interface. The result will be unwanted emission via the unshielded S-cable. Both 10 $\mu$ H inductances avoid the coupling from GND and VDD to the S-interface. If proper GND and VCC are available, the inductances are probably not necessary, i.e. they could be bridged.

The same is applicable for the 100nF capacitors. In addition, voltage peaks are compensated before the zener diode SMBJ6.0 breaks through. The SMBJ6.0 zener diode is useful if high-energy pulses (surge) are present on S. Currently the surge protection is not mandatory in Germany.

Generally, the diode-arrays are suppressing voltage peaks. That is at the receiver side VDD+0.7V and GND-0.7V. In transmit direction there is also a zener diode 2V7 included in the diode-array to fulfill the 96 kHz impedance tests with the unit powered off, i.e. the voltage range at SX1 and SX2 is between GND-0.7V and VDD+3.4V or VSMBJ6.0+3.4V (depending on the pulse shape and the influence of the 10 $\mu$ H inductance connected to VDD and the zener diode).

The splitted 10kOhm Resistor (1K8 + 8K2) and the diode array are limiting the voltage and the current peaks. Therefore the chip is well protected.

On the PCB there should be no power planes in the area of the S-interface.

*Note: The EMI optimization depicted in the schematics was successfully used with the Stollmann Terminal Adapter (SIPB 72115 TA). This TA has its own power supply and is located in a metal case. The described S-interface schematic gives some hints for other designs but they could need adapted solutions! The components marked as “\*option” are not mandatory but useful for EMI and noise suppression.*

## 2.2 Overvoltage protection

The overvoltage protection is not mandatory at the BZT but EMI and low-voltage guidelines must be guaranteed by the manufacturer.

Low-Voltage guidelines: ETS300047-2 page 7, last sentence: S-circuit = SELV (Safety Extra-Low Voltage) circuit, i.e. no high-voltage capacitors are necessary (2.2nF, 56pF). The used SELV definition is based on EN60950 (Issue2,1996).

ETS300047-3: §5.7.1-5.7.3 were measured with TBR3. The termination networks used in TBR3 do not need the use of high-voltage capacitors.

EMI interference immunity EN 50082 with reference to IEC801-4 burst. During this test it is not possible to foresee the voltage peaks at the coupling capacitors (2.2nF). Therefore 500 Volt types were used.