

### General Description

The Signal Processing Codec Filter (PEB 2465-H), SICOFI-4 is the interface between four analog subscribers and the digital switch. The chip combines all the circuitry needed for encoding, decoding and PCM filtering of 4 speech channels on CMOS chip. An integrated digital signal processor (DSP) allows the analog line card to be adapted to the widest variety of national specifications and applications by programming the individual digital filter functions. A wide variety of SLICs (subscriber line interface circuits) can be employed and simply adapted.

The SICOFI-4 can be used in both, PBXs and public switches. The external configuration does not vary – only decoupling capacitors are needed. Widely differing national specifications can be met with a single hardware by just changing the filter coefficients: Signal level, terminating impedance, equivalent impedance, frequency response correction and the required coding procedure (A- or  $\mu$ -Law) are simple to program. Siemens provides well proven software for calculating the required coefficients.

The SICOFI-4, together with standard SLICs, also fulfills the new specification for idle channel noise in the out-of-band range, already demanded by Japan and Great Britain.

A flexible test concept operating at component level as well as at system level is provided to support users in designing and manufacturing their systems. The following test options are integrated into the SICOFI-4:

- BIST (built-in self test) in the digital part
- Boundary scan as per IEEE 1149.1
- Functional testing with various test loops
- Simple stimulation by two built-in DTMF (Dual Tone Multifrequency) tone generators
- Function self test using what is known as the "level metering function" with which not only the chip but also the SLIC connected to it can be tested (system test).

The powerful, modular IOM-2 interface implemented on the allows minimal wiring to be used on the board and thereby a low-cost design. A suitable controller (e.g. the ELIC, PEB 20550-H) is used to direct the relevant coefficients for filter programming and the required control signals as well as the voice signals to the SICOFI-4. Signals from the SLIC can be issued by the SICOFI-4 to the IOM-2 interface and read out under interrupt control. This significantly reduces the load on the microcontroller.

Type	Package
PEB 2465-H	P-MQFP-64-1 (SMD)

### Features

- Codec for four analog subscribers (public switch and PBX) usable towards the trunk and the subscriber
- Specification according to relevant CCITT, EIA and LSSGR
- IOM-2 interface
- Usable with transformer and electronic SLICs
- DSP technology
- Adaption to different country specifications with following programmable filters
  - AC impedance matching (return loss better than 30 dB)
  - transhybrid balancing (better than 30 dB)
  - frequency response
  - gain (steps of 0.05 dB)
- Advanced test capabilities
- DTMF generator
- Level metering function
- Boundary scan
- Single 5-V power supply

### Applications

PBXs:

- 4 analog lines for subscribers and trunks

CO:

- Interface for four analog subscribers

### Interfaces

- $4 \times$  t/r interface
- IOM-2 interface
- Eight I/O signaling pins per channel
- Boundary scan

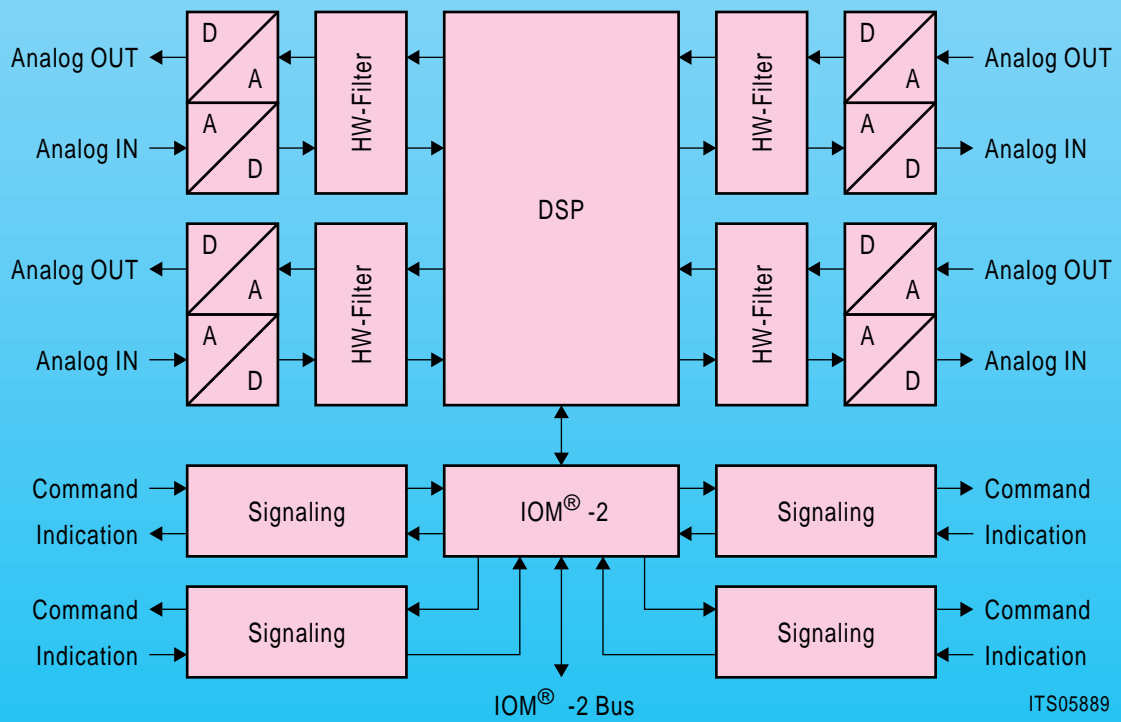

**Block Diagram**