



## **Application**

This manual has been issued by Canon Inc. for qualified persons to learn technical theory, installation, maintenance, and repair of products. This manual covers all localities where the products are sold. For this reason, there may be information in this manual that does not apply to your locality.

## **Corrections**

This manual may contain technical inaccuracies or typographical errors due to improvements or changes in products. When changes occur in applicable products or in the content of this manual, Canon will release technical information as the need arises. In the event of major changes in the contents of this manual over a long or short period, Canon will issue a new editions of this manual.

**The following paragraph does not apply to any countries where such provisions are inconsistent with local law.**

## **Trademarks**

The product names and company names described in this manual are the registered trademarks of the individual companies.

## **Copyright**

This manual is copyrighted with all rights reserved. Under the copyright laws, this manual may not be copied, reproduced or translated into another language, in whole or in part, without the written consent of Canon Inc.

**Copyright © 1999 by Canon Inc.**

**CANON INC.**

**Office Imaging Products Technical Support Dept. 3**

**5-1 Hakusan 7-Chome, Toride-city, Ibaraki 302-8501, Japan**

## **DTP System**







This manual was produced on an Apple Macintosh®, personal computer, final pages were printed on AGFA SelectSet Avantara 25.

All graphics were produced with MACRO MEDIA FREEHAND 8.0J®

All documents and all page layouts were created with ADOBE Page Maker 6.5J®

# I. MEANINGS OF MARKS

The marks used in this manual have the following meanings.

Mark	Meaning
	States a precaution to be taken to prevent danger to personnel, damage to the product, or damage to electronic components by discharge of static electricity. for example.
	States a precaution to be taken to prevent damage to electronic components by electrostatic discharge.
	Informs you of fire-related cautions.
	Informs you that the plug must be removed from the power outlet before starting an operation.
 NOTE	Gives useful information to understand descriptions.
 REFERENCE	Indicates sections to be read to obtain more detailed information.

## II. ABOUT THIS MANUAL

This manual is divided into four parts, and contains information required for servicing the product.

### **Chapter 1: General Description**

This part explains product specifications and the how to service the unit safely.

### **Chapter 2: Technical Reference**

This part explains the technical theory of the product.

### **Chapter 3: Maintenance and Service**

This part explains how to maintain the products for service operations, troubleshooting and service switches.

### **Chapter 4: Appendix**

This part explains the information of the installation, optional products and user data flow.



#### **REFERENCE**

- 
- For more details of user operations and user reports, see the separate volume of *USER'S GUIDE*.
  - Procedure for assembly/disassembly and greasing points are not given in this manual. See the illustrations in the separate volume of *PARTS CATALOG*.
  - Detailed description of each SSSW/parameter is not given in this manual except the new SSSWs/parameters added to this model.  
See *G3 Facsimile Service Data Handbook (supplied separately)* for details them.
  - See the *G3 Facsimile Error Code List (Rev.1, supplied separately)* for details of the error codes not shown in this manual.  
Details regarding D-channel error codes and B-channel error codes are mentioned in this manual.
  - Detailed description of connector Locations and Signal Descriptions in not given in this manual.  
See the *Circuit Diagram* for details them.
-

### III. REVISION HISTORY

<i>REVISION</i>	<i>CONTENT</i>
0	Original
1	Updates to Service Information HS-E5E-9015-01, as issued by Canon Inc.

## IV. TABLE OF CONTENTS

### *Chapter 1: General Description*

Page	
1-1	1. FEATURES
1-1	1.1 Overview
1-3	2. SPECIFICATIONS
1-3	2.1.General Specification
1-3	2.2 Communication Specification
1-5	2.3 Scanner Specification
1-7	2.4 Printer Specification
1-9	2.5 Copy Specifications
1-9	2.6 Function
1-12	3. OVERVIEW
1-12	3.1 External View
1-14	3.2 Operation Panel
1-17	3.3 Option
1-17	3.4 Consumable
1-18	4. DIMENSIONS
1-20	5. SAFETY & PRECAUTIONS
1-20	5.1 Personnel Hazards
1-22	5.1.1 Electrical shock
1-22	5.1.2 High-temperature parts
1-23	5.1.3 Fire hazards
1-23	5.1.4 Moving parts
1-24	5.1.5 LASER beams
1-25	5.2 General Cautions
1-25	5.2.1 Unit cautions
1-29	5.2.2 Toner cartridge cautions
1-30	5.3 Servicing Cautions
1-30	5.3.1 Damage from static charge
1-30	5.3.2 Scanner section
1-31	5.3.3 Printer section
1-32	5.3.4 Paper feed section
1-33	5.3.5 Control boards
1-34	5.4 Data-related precautions
1-34	5.4.1 Data in the image storage memory (DRAM)
1-36	5.4.2 Data in the control processing memory (SRAM)
1-37	5.4.3 SCNT board replacement precautions
1-39	5.4.4 Data initialization through service operation

1-40	5.5 Protective Mechanism
1-40	5.5.1 Data battery backup function
1-40	5.5.2 Overcurrent protection
1-40	5.5.3 Lightning protection
1-40	5.5.4 Power leakage protection
1-41	6. QUALIFICATION REQUIRED FOR INSTALLATION WORK

### ***Chapter 2: Technical Reference***

2-1	1. DRIVE/ELECTRICAL SYSTEM LAYOUT
2-4	2. SCANNER MECHANISM
2-8	3. PAPER SUPPLY SECTION
2-12	4. PRINTER SECTION
2-13	4.1 LASER/Scanner Section
2-13	4.2 Toner Cartridge
2-13	4.3 Toner Transfer Section
2-13	4.4 Fixing Section
2-14	4.5 Paper Feed/Eject Section
2-17	5. ELECTRIC CIRCUIT
2-17	5.1 Component Block Diagram
2-18	5.2 Circuit Board Components
2-24	5.3 Flow of Image Signals
2-28	6. COMMUNICATION SYSTEM OPERATIONS
2-28	6.1 ISDN Protocol Messages
2-28	6.1.1 D-channel messages
2-29	6.1.2 B-channel messages
2-32	6.2 D-Channel Standard Protocol
2-33	6.2.1 Information elements in the SETUP message
2-34	6.3 B-Channel Standard Protocol
2-35	7. NEW FUNCTION

### ***Chapter 3: Maintenance & Service***

3-1	1. MAINTENANCE LIST
3-1	1.1 Consumables
3-1	1.2 Cleaning
3-2	1.3 Periodic Inspection
3-2	1.4 Periodic Replacement Parts
3-3	1.5 Adjustment Items
3-3	1.6 General Tools
3-3	1.7 Special Tools
3-4	2. HOW TO CLEAN PARTS
3-4	2.1 Main Unit Outer Covers
3-4	2.2 Separation Roller

3-4	2.3 Separation Guide
3-4	2.4 White Sheet
3-4	2.5 Scanning Glass (Contact Sensor)
3-4	2.6 Paper Feed Guide
3-6	2.7 Paper Pickup Roller
3-6	2.8 Transfer Charging Roller
3-6	2.9 Static Charge Eliminator
3-6	2.10 High Voltage Terminal
3-6	2.11 Fixing Entrance Guide
3-6	2.12 Paper Face-up Eject Roller
3-6	2.13 Flapper
3-6	2.14 Document Feed Roller, Document Eject Roller
3-6	2.15 Pressure Roller
3-6	2.16 Fixing Ass'y
3-6	2.17 Separation Pad
3-8	3. REPLACING PARTS & ADJUSTMENTS
3-8	3.1 Replacing parts
3-8	3.2 Adjustment
3-9	4. TROUBLESHOOTING
3-9	4.1 Troubleshooting Index
3-10	4.2 Errors Shown on the Display
3-10	4.2.1 User error message
3-13	4.2.2 Error codes
3-44	4.3 Errors not Shown on the Display
3-44	4.3.1 General errors
3-45	4.3.2 Printing problems
3-51	4.3.3 Scanning problems
3-52	4.3.4 Communication problems
3-53	5. SERVICE SWITCHES
3-53	5.1 Hardware Switches
3-54	5.2 Service Data Settings
3-54	5.2.1 Service data overview
3-55	5.2.2 Service data registration/setting method
3-56	5.2.3 Service data settings
3-64	5.2.4 Explanation of service data
3-65	5.2.5 New SSSWs/parameters added to this model
3-90	6. TEST FUNCTIONS
3-90	6.1 Service Test Functions
3-90	6.1.1 Test mode overview
3-91	6.1.2 Test mode flowchart
3-92	6.1.3 D-RAM tests



3-93	6.1.4 Print
3-94	6.1.5 Modem tests
3-95	6.1.6 Faculty tests
3-99	7. SERVICE REPORT
3-99	7.1 Report Output Function
3-99	7.1.1 User report output functions
3-101	7.1.2 Service report output functions
3-115	8. WIRING DIAGRAM
3-115	8.1 Wiring Diagram
3-116	8.2 Connector Name and Signal Descriptions

***Chapter 4: Appendix***

4-1	1. INSTALLING THE FAX-L260i
4-1	1.1 Setting Up
4-1	1.2 Checking Operations
4-2	2. USER DATA FLOW
4-2	2.1 User Data Flow
4-5	3. SPECIAL MODE FLOW
4-6	4. MAKER CODE

***INDEX***

## V. ILLUSTRATION INDEX

### **Chapter 1: General Description**

Page			
1-6	Figure	1-1	Scanning Range
1-8	Figure	1-2	Printing Range
1-12	Figure	1-3	External View (1)
1-13	Figure	1-4	External View (2)
1-14	Figure	1-5	Operation Panel (1)
1-15	Figure	1-6	Operation Panel (2)
1-16	Figure	1-7	Operation Panel (3)
1-18	Figure	1-8	Dimensions
1-20	Figure	1-9	Personnel Hazards (1)
1-21	Figure	1-10	Personnel Hazards (2)
1-24	Figure	1-11	LASER beam warning label
1-25	Figure	1-12	Unit Cautions (1)
1-26	Figure	1-13	Unit Cautions (2)
1-27	Figure	1-14	Unit Cautions (3)
1-28	Figure	1-15	Unit Cautions (4)
1-29	Figure	1-16	Precautions for Handling Cartridge
1-32	Figure	1-17	Precaution for Handling LASER/scanner Unit
1-34	Figure	1-18	Backed up Devices
1-35	Figure	1-19	Reception Image Data Transfer
1-39	Figure	1-20	All Clear and Type Setting

### **Chapter 2: Technical Reference**

2-1	Figure	2-1	Drive System Layout
2-2	Figure	2-2	Electrical System Layout
2-4	Figure	2-3	Scanner Section
2-8	Figure	2-4	Paper Supply Section
2-12	Figure	2-5	Printer Section
2-16	Figure	2-6	Paper Delivery Slot Switching
2-17	Figure	2-7	Component Block Diagram
2-20	Figure	2-8	G4 Board Block Diagram
2-24	Figure	2-9	Transmission Image Signal Flow
2-26	Figure	2-10	Reception Image Signal Flow
2-32	Figure	2-11	D-Channel Protocol Flow
2-34	Figure	2-12	B-Channel Protocol Flow

### **Chapter 3: Maintenance and Service**

3-5	Figure	3-1	Cleaning Location 1
3-7	Figure	3-2	Cleaning Location 2
3-13	Figure	3-3	Service Error Code Display
3-45	Figure	3-4	Main Motor Connector
3-46	Figure	3-5	Faulty Print Samples
3-50	Figure	3-6	Fixing Nip Width
3-51	Figure	3-7	Document Feed Motor Connector
3-55	Figure	3-8	Service Data Setting Method
3-56	Figure	3-9	Service Data (page 1)
3-57	Figure	3-10	Service Data (page 2)
3-58	Figure	3-11	Service Data (page 3)
3-59	Figure	3-12	Service Data (page 4)
3-60	Figure	3-13	Service Data (page 5)
3-61	Figure	3-14	Service Data (page 6)
3-62	Figure	3-15	Service Data (page 7)
3-64	Figure	3-16	Bit Switch Display
3-64	Figure	3-17	How to Read Bit Switch Tables
3-75	Figure	3-18	G4 G3 Fallback Procedure (1)
3-75	Figure	3-19	G4 G3 Fallback Procedure (2)
3-91	Figure	3-20	Test Mode
3-92	Figure	3-21	D-RAM Test
3-93	Figure	3-22	Print Pattern Check
3-96	Figure	3-23	Sensor Tests
3-98	Figure	3-24	Operation Panel
3-100	Figure	3-25	Memory Clear List
3-102	Figure	3-26	System Dump List (1/2)
3-104	Figure	3-27	System Dump List (2/2)
3-106	Figure	3-28	Dch Dump List
3-110	Figure	3-29	Bch Dump List (Erroneous Communication)
3-112	Figure	3-30	Bch Dump List (Normal Communication)
3-113	Figure	3-31	Service Error Tx Report
3-114	Figure	3-32	Service Error Activity Report (receiving)
3-115	Figure	3-33	Wiring Diagram

### **Chapter 4: Appendix**

4-2	Figure	4-1	User Data Flow (1/3)
4-3	Figure	4-2	User Data Flow (2/3)
4-4	Figure	4-3	User Data Flow (3/3)
4-5	Figure	4-4	Special Mode Flow
4-6	Figure	4-5	Maker Code

**This page intentionally left blank**

# ***Chapter 1***

## ***General Description***



# 1. FEATURES

## 1.1 Overview

This product is a G4/G3 transceiving facsimile based on the ITU-T recommendation. It can be used in Euro-ISDN.

\*: This mark indicates new function

### **High image quality**

Ultra-high quality image processing. Gives faithful reproduction of documents.

### **Plain paper printing with LBP**

The printer section uses an LBP which employs an on-demand fixing system, operating the fan and fixing heater only when printing, and prints on plain paper.

### **Excellent print quality and speed**

This product offers 600×600 dpi laser beam printing, providing you with high resolution text and graphics. The exceptional printing speed of 6 pages per minute allows you to work more effectively.

### **Toner detection function**

This unit uses a magnetic (permeability) sensor to detect remaining toner.

### **Automatic dialing**

There are 16 one-touch dial locations, and 100 coded-speed dial locations. Registered numbers can be retrieved using the telephone directory feature.

### **ECM transmission**

The ECM system provides communication error detection and retransmission of image data.

### **Memory reception**

No need to worry about toner or recording paper running out in the middle of a reception. Received documents are stored in memory until they can be output later.

### **Delayed transmission**

Documents can be sent automatically, at a preset time. This means that documents can be sent late at night, thus reducing transmission costs.

### **ON-HOOK Dial Function**

Used in the event of facsimile information service. After dialing and connecting to the remote terminal, it is possible to send a DTMF signal and have manual communication.

### **Subaddress/Password Communications Function**

Transmissions using “Subaddress” and “Password” which conform to the ITU-T standard can be used with this machine.

Convenient uses can be found when used in combination with the other terminal’s memory box function, etc. It can use both G4 and G3 communications.

**Polling Receiving Function**

Using this function, a document placed at the other party's terminal may be taken out.

This can also be used in combination with "Subaddress" and "Password" which conform to the ITU-T standard.

It can use both G4 and G3 communications.



## 2. SPECIFICATIONS

### 2.1 General Specification

<b>Type</b>	Desktop
<b>Body colour</b>	Art gray
<b>Power source</b>	187 ~ 264V AC, 48 ~ 62 Hz,
<b>Power consumption</b>	standby less than 11W / less than 504W (when operating)
<b>Usage environment</b>	50.0°F ~ 90.5°F (10°C ~ 32.5°C), 20%~85% RH Horizontal ±3° or less
<b>Operating noise</b>	Measured in accordance with ISO standards Standby :Max. 30dB Copy :Max. 50dB
<b>Dimensions (W × D × H)</b>	365 mm × 365mm × 242 mm (Not including Trays)
<b>Weight</b>	18.96 lbs (8.6 kg) Including trays

### 2.2 Communication Specification

<b>Applicable lines</b>	Euro-ISDN
<b>Handset</b>	None
<b>Communication method</b>	Half-duplex
<b>Communication control protocol</b>	
<b>G4</b>	ITU-T T.62
<b>G3</b>	ITU-T T.30
<b>Modulation method</b>	
<b>G3 image signals</b>	ITU-T V.27ter (2.4k, 4.8k bps) ITU-T V.29 (7.2k, 9.6k bps) ITU-T V.33 (12k, 14.4k bps) ITU-T V.17 (TC7.2k, TC9.6k, 12k, 14.4k bps)
<b>G3 procedure signals</b>	ITU-T V.21 (No.2) (300bps) (With automatic fallback function)
<b>Coding</b>	
<b>G4</b>	ITU-T T.6 Coding method (MMR)
<b>G3</b>	ITU-T T.4 Coding method (MH, MR) ITU-T T.6 Coding method (MMR)
<b>Canon express protocol (CEP)</b>	None

**Transmission time\***

<b>G4 (64 kbps)</b>	approx. 3 sec.
<b>G3 (14.4 kbps)</b>	
<b>ECM-MMR</b>	approx. 6 sec.
<b>MR</b>	approx. 12 sec.

\*Based on Canon FAX Standard Chart No.1, A4, standard mode

**Communication speed**

<b>G4</b>	64 kbps, 56 kbps
<b>G3</b>	14.4 kbps, 12 kbps, 9.6 kbps, 7.2 kbps, 4.8 kbps, 2.4 kbps

---

**Time required for transmission protocol**

<b>Mode</b>	<b>Pre-message Protocol *1</b>	<b>Post-message Protocol *2 (between pages)</b>	<b>Post-message Protocol *3 (after pages)</b>
G3	approx.12 sec.	approx.4 sec.	approx.3.5 sec.
G4	approx.1.1 sec.	approx.1 sec.	approx.0.6 sec.

\*1 Time from when other facsimile is connected to the line until image transmission begins.

\*2 Post-message (between pages): Time from after one document has been sent until transmission of the next document starts if several pages are transmitted.

\*3 Post-message (after last pages): Time from after image transmission is completed until the circuit closes.

**Communication resolution**

	<b>G4</b>	<b>G3</b>
<b>Transmission</b>	200 dpi × 100 dpi 200 dpi × 200 dpi 400 dpi × 400 dpi	8 dots/mm × 3.85 lines/mm 8 dots/mm × 7.7 lines/mm 8 dots/mm × 15.4 lines/mm 16 dots/mm × 15.4 lines/mm
<b>Reception</b>	200 dpi × 100 dpi 200 dpi × 200 dpi 400 dpi × 400 dpi	8 dots/mm × 3.85 lines/mm 8 dots/mm × 7.7 lines/mm

---

**Supplementary service**

<b>MSN (Multiple Subscriber Number)</b>	Yes
<b>CLIP (Calling Line Identifier Presentation)</b>	Yes
<b>CLIR (Calling Line Identifier Restriction)</b>	Yes
<b>COLP (Connected Line Identifier Presentation)</b>	Yes* <sup>1</sup>
<b>CFU (Call Forwarding Unconditional)</b>	Yes* <sup>2</sup>
<b>AOC (Advice of Charge)</b>	Yes* <sup>1</sup>

\*1: German, Italy, only

\*2: German only

<b>Minimum transmission time</b>	10 msec. (MH,MR), 0 msec. (MMR)
<b>Transmission output level</b>	from -15 to 0 dBm
<b>Receive input level</b>	from -43 to 0 dBm
<b>Modem IC</b>	R144EFXL

**2.3 Scanner Specification**

<b>Type</b>	Sheets
<b>ADF capacity</b>	Max. 20 sheets (A4/Letter) Max. 10 sheets (Legal)
<b>Effective scanning width</b>	Letter/Legal 8.42" (214 mm) A4 208 mm (8.19")
<b>Scanning method</b>	Contact sensor scanning method
<b>Scanning speed</b>	Standard 8.7 sec./page Fine 17.5 sec./page
<b>Image modes</b>	Halftone (PHOTO mode)
<b>Scanning density adjustment</b>	3 density level
<b>Halftone</b>	64-gradation error diffusion system (UHQ)

## Scanning range

Sheet dimensions (W × L)

Maximum	218 mm × 1000 mm (8.58" × 39.3")
Minimum	88.9 mm × 44.45 mm (3.5" × 1.75")
Thickness	
multiple pages:	0.06 mm ~ 0.13 mm (0.002" ~ 0.005") 40~90 g/m <sup>2</sup>
1 pages:	0.06 mm ~ 0.43 mm (0.002" ~ 0.017") 34.7~340 g/m <sup>2</sup>

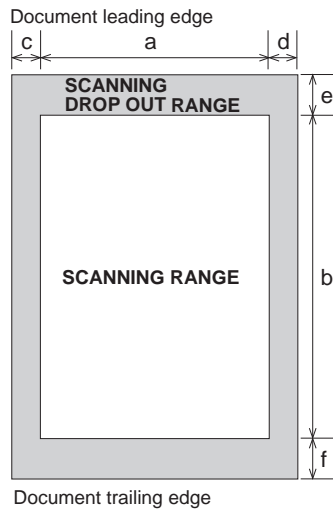

Figure 1-1 Scanning Range

Item	A4	Letter	Legal
a Effective scanning width	208 ±0.5 mm	8.42"±0.02"	8.42"±0.02"
b Effective scanning length	293 ±3.0 mm	10.84"±0.12"	13.84"±0.12"
c Left margin	1.0 ±2.0mm	0.04" ±0.08"	0.04" ±0.08"
d Right margin	1.0 ±2.5 mm	0.04" ±0.10"	0.04" ±0.10"
e Top margin	2.0 ±2.0 mm	0.08" ±0.08"	0.08" ±0.08"
f Bottom margin	2.0 ±2.0 mm	0.08" ±0.08"	0.08" ±0.08"



**NOTE**

- Document scanning width “A4/LTR” is set in service data #1 SSSW SW06, bit4.
- Skew area is not taken into consideration.
- The feed precision of the original is included in the scanning range values.

## 2.4 Printer Specification

<b>Printing method</b>	LASER Beam Printer (based on the LBP-660 printer)
<b>Printing Cartridge</b>	
Products name	Canon FX3 Cartridge
Product code	H11-6381-117
Valid period	Displayed on carton (2.5 years from date of manufacture)
Storage conditions	Temperature from 32.0°F to 95.0°F (0°C to 35°C) Humidity from 35% to 85% RH
Yeild	Approx. 2700 pages (black rate 4% chart)
<b>Toner detection</b>	Yes (Toner out detect)
<b>Printing speed</b>	Approx. 6 pages/minute
<b>Paper output tray stacking (when using the recommended paper)</b>	
Face down delivery slot	Approx. 50 sheets
Face up delivery slot	1 sheet
<b>Paper tray</b>	
Paper supply method	ASF (Auto Sheet Feeder)
Number of paper tray	1tray : Legal/Letter/A4 (Universal)
Paper capacity	Max. 0.40" (10 mm) thickness plain paper (Approx. 100 sheets)
<b>Recommended paper</b>	
<b>KANGAS</b>	
Weight	80 g/m <sup>2</sup>
Paper size	A4
Manufactured by	KANGAS
<b>NEUSIEDLER Canon Paper</b>	
Weight	80 g/m <sup>2</sup>
Paper size	A4
Manufactured by	NEUSIEDLER

**Printing range**

Paper dimensions (W × L)

Maximum	216 mm × 356 mm (8.50" × 14.02")
Minimum	76.2 mm × 127 mm (3.00" × 5.00")
Letter	216 mm × 279 mm (8.50" × 10.98")
Legal	216 mm × 356 mm (8.50" × 14.02")
A4	210 mm × 297 mm (8.27" × 11.69")
Thickness	64~90g/m <sup>2</sup>

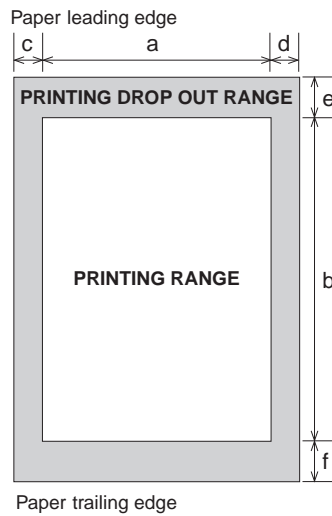

**Figure 1-2 Printing Range**

Item	A4	Letter	Legal
a Effective printing width	206 ±2.0 mm	8.34" ±0.08"	8.34" ±0.08"
b Effective printing length	288.9 ±3.0 mm	10.68" ±0.12"	13.68" ±0.14"
c Left margin	2.0 ±2.0 mm	0.08" ±0.08"	0.08" ±0.08"
d Right margin	2.0 ±3.0 mm	0.08" ±0.12"	0.08" ±0.12"
e Top margin	2.0 <sup>+3.5</sup> <sub>-2.0</sub> mm	0.08" <sup>+0.14</sup> <sub>-0.08</sub> "	0.08" <sup>+0.14</sup> <sub>-0.08</sub> "
f Bottom margin	6.1 <sup>+3.4</sup> <sub>-4.8</sub> mm	0.24" <sup>+0.13</sup> <sub>-0.19</sub> "	0.24" <sup>+0.15</sup> <sub>-0.21</sub> "



**NOTE**

- The header and footer are printed in the printing range.
- Skew area is not taken into consideration.
- The feed precision of the original is included in the scanning range values.
- Print area when all-black pattern from Test Print modes are outputted.

## 2.5 Copy Specifications

<b>Color copy</b>	None	
<b>Multiple copy</b>	99 copies	
<b>Copy resolution</b>	Scanning	600 dpi × 300 dpi (direct copy) 300 dpi × 300 dpi (memory copy)
	Printing	600 dpi × 600 dpi
<b>Copy magnification ratio</b>	100%, 90%, 80%, 70%	



**NOTE**

- When one copy is specified at a magnification ratio of 100%, the direct copy mode is entered. When two or more copies are specified, the memory copy mode is entered.
- When the magnification ratio is 90%, 80% or 70%, the memory copy mode is entered.
- When long originals are scanned in the direct copy mode, only the area that can be printed on a single page is copied, and copies are not made over multiple pages.

## 2.6 Function

<b>Dialling</b>	
Manual dialling	Numeric button
Auto dialling	Maximum 50 digits/Average 39 digits/Optimal/32 digits One-touch:16, Coded speed:100
Group dial	Max.115 locations
Redial	Numeric button redial function
ON-HOOK dialling	Yes
<b>Transmission</b>	
Broadcast transmission	Max. 117 locations (One-touch:16, Coded speed:100, Numeric button:1)
Delayed transmission	No. of Destination MAX. 117 No. of Reservation MAX. 20
Confidential Tx/Rx	None
Relay broadcasting originating	None
Relay broadcasting	None
Subaddress/Password sending	Yes
<b>Reception</b>	
Reduction settings for reception (vertical only)	Yes
Automatic reduction of reception images	Yes (100%~70%)
Memory lock reception	None
Reception printing in reverse order	Yes (When using face-down delivery slot)
<b>Polling</b>	
Polling transmission	None
Polling reception	Yes

**Others**

**Dual access**

File No. of reservation Max. 20 files

**Closed network**

None

**Direct mail preventive**

Yes

**Memory box**

None

**Memory backup**

Backup contents Dial registration data, User data, Service data, Time

Backup IC 256 kbit SRAM for control

Backup device Lithium battery 3.0V DC/600 mAh

Battery life Approx. 5 years

**Image memory**

DRAM Approx. 3.75 Mbyte

Page Approx. 230 pages\*

\* Based on Canon FAX Standard Chart No.1, A4, standard mode.

**Image data backup**

None

**Activity management**

Yes

**a) User report**

One-touch speed dialling list

Coded speed dialling list

Group dialling list

User's data list

Activity report (Every 20 transactions: always transmission and reception together)

Activity report (sending/receiving)

Memory clear list

Multi activity report

**b) Service report**

System data list

ISDN data list

System dump list

Dch dump list

Bch dump list

Error list

**Transmitting terminal identification**

Yes

**Time**

Management data Year/month/date/day/hour/minute (24 hour display)

Precision ±60 sec per month

**Display**

1 row × 16 digits

**Completion stamp**

None

**Program key**

None

**Telephone exchange function**

None

**Reception footer**

Yes

---



**This page intentionally left blank**

## 3. OVERVIEW

### 3.1 External View

#### Front View

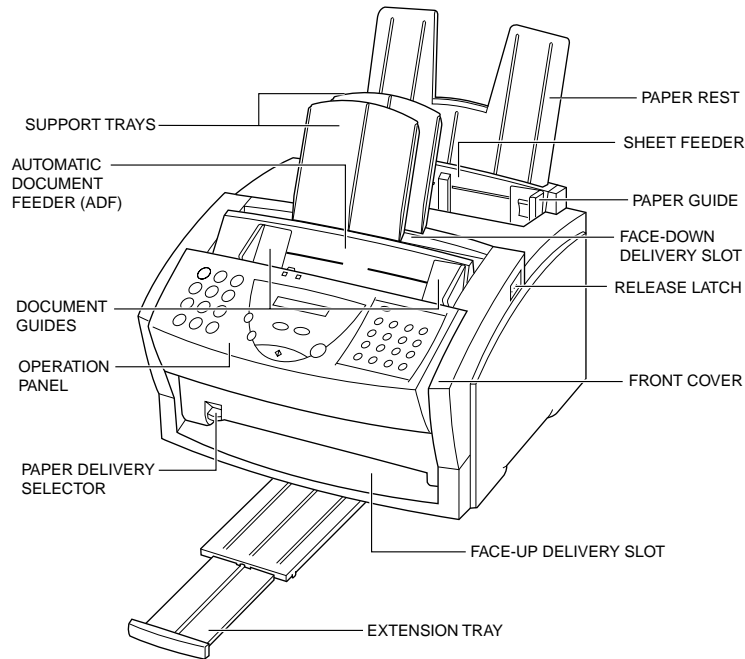

#### Inside View

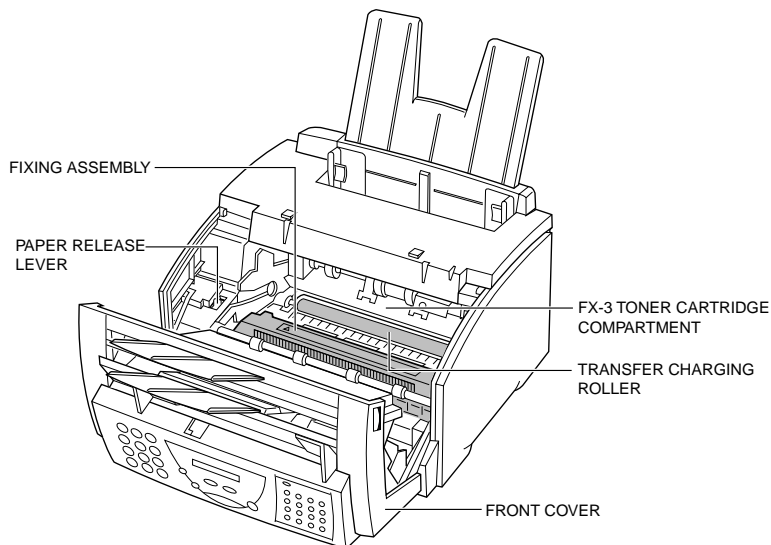
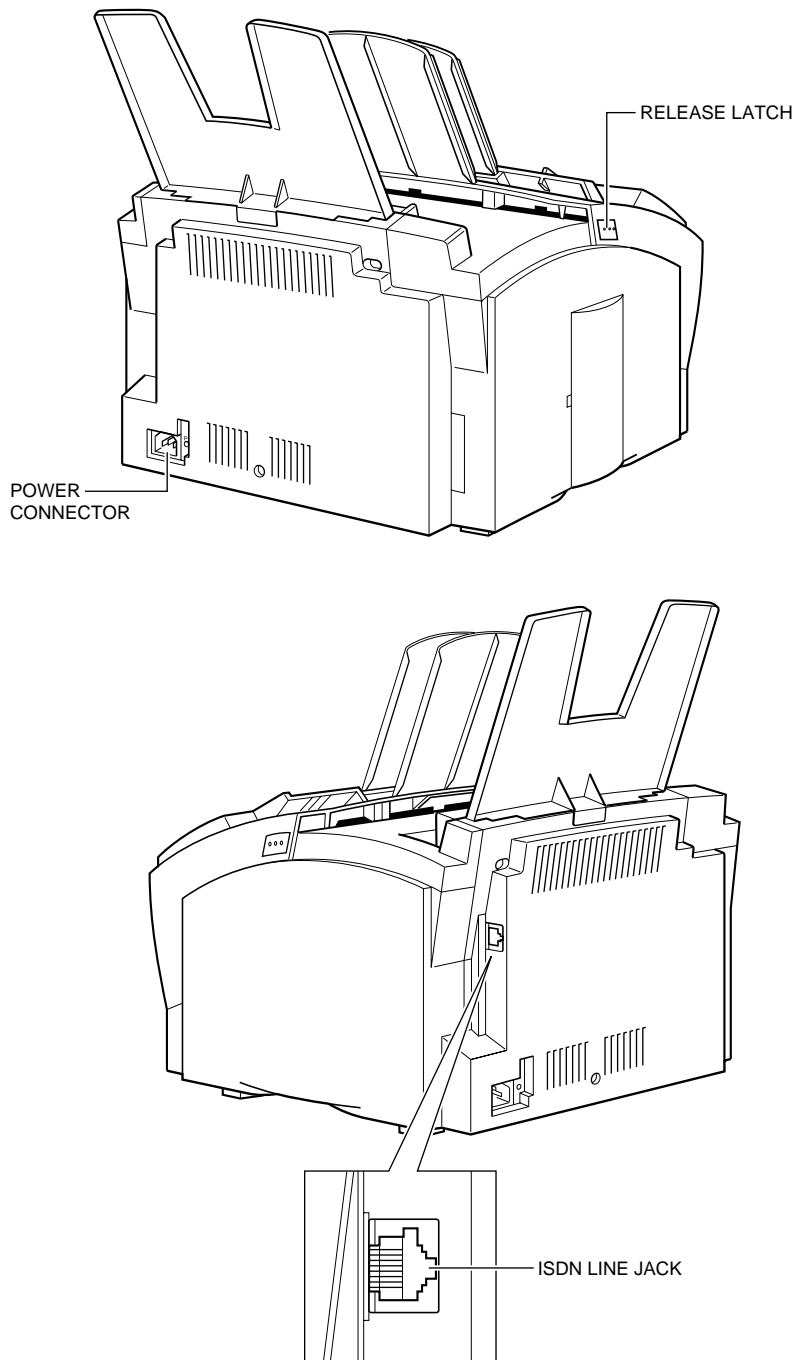

Figure 1-3 External View (1)

**Rear View**



**Figure 1-4 External View (2)**

### 3.2 Operation Panel

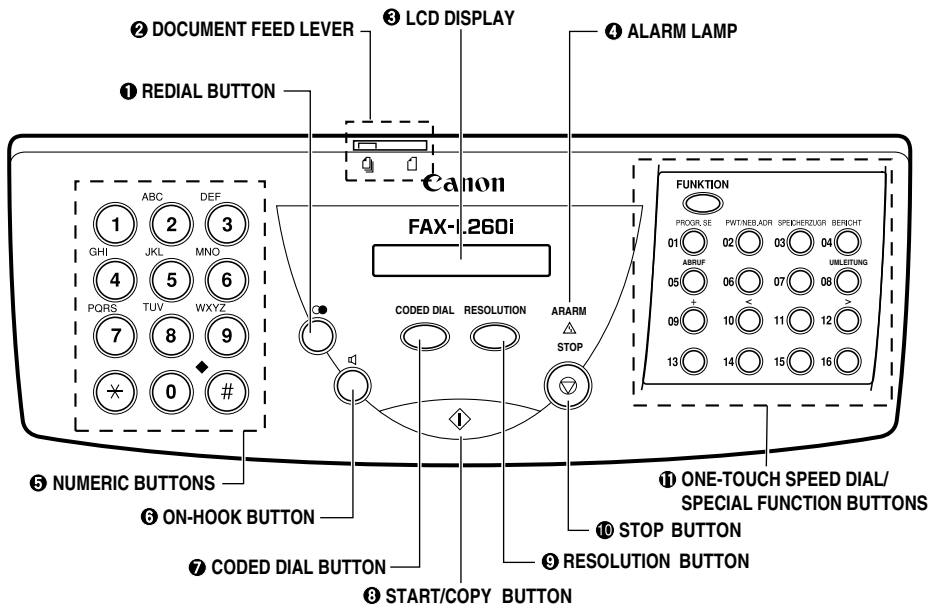



- 1 REDIAL button**  
Press this button to redial the last number that was dialed using the numeric buttons.
- 2 Document feed lever**  
Set this lever to the left (  ) for automatic document feed, or to the right (  ) for manual document feed.
- 3 LCD display**  
The LCD display shows messages and prompts during operation, and displays selections, text, numbers and names when registering information.
- 4 ALARM lamp**  
This lamp flashes when an error occurs, or when the FAX-L260i is out of paper or toner.

Figure 1-5 Operation Panel (1)

- ⑤ **Numeric buttons**  
Use these buttons to enter numbers and names when registering information, and to dial fax numbers that are not registered for automatic dialling.
- ⑥ **ON-HOOK button**  
Use this button to access "touch-line" services.
- ⑦ **CODED DIAL button**  
Press this button and a two-digit code to dial a fax number that you have registered for coded speed dialling.
- ⑧ **START/COPY button**  
Press this button to begin sending, scanning, copying or other operations, or to select functions when registering information.
- ⑨ **RESOLUTION button**  
Press this button to select the resolution the FAX-L260i will use for the document you want to fax or copy.
- ⑩ **STOP button**  
Press this button to cancel sending, receiving, or any other operation.
- ⑪ **One-Touch Speed Dial/Special Function buttons**  
Use these buttons for one-touch speed dialling and to perform special operations. See pages 2-22 and 2-23 for details on the special function buttons.

**Figure 1-6 Operation Panel (2)**

### Special Function Buttons

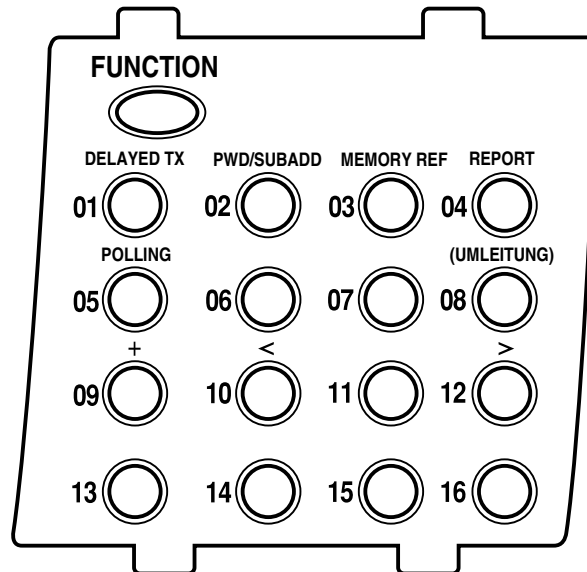

- ❑ **FUNCTION button**  
Use this button to enable access to the special function buttons described below.
- ❑ **DELAYED TX button 01**  
Press this button to register a time for delayed sending.
- ❑ **PWD/SUBADD button 02**  
Press this button to send a document using a password and subaddress based on the ITU-T standard.
- ❑ **MEMORY REF button 03**  
Use this button to delete or resend documents stored in memory, or to print a list of documents in memory.
- ❑ **REPORT button 04**  
Use this button to print activity reports.
- ❑ **POLLING RX button 05**  
Press this button for polling reception.
- ❑ **FORWARDING button 08 (German only)**  
Use this button to activate/disactivate the received document forwarding function.
- ❑ **+ button 09**  
Press this button to enter a + sign when registering your fax number.
- ❑ **<, > (Arrow) buttons 10 and 12**  
Use these buttons to scroll through menu selections or to move the cursor when registering data.

Figure 1-7 Operation Panel (3)

### **3.3 Option**

None

### **3.4 Consumable**

#### **Toner cartridge**

FX3 cartridge is used.

## 4. DIMENSIONS

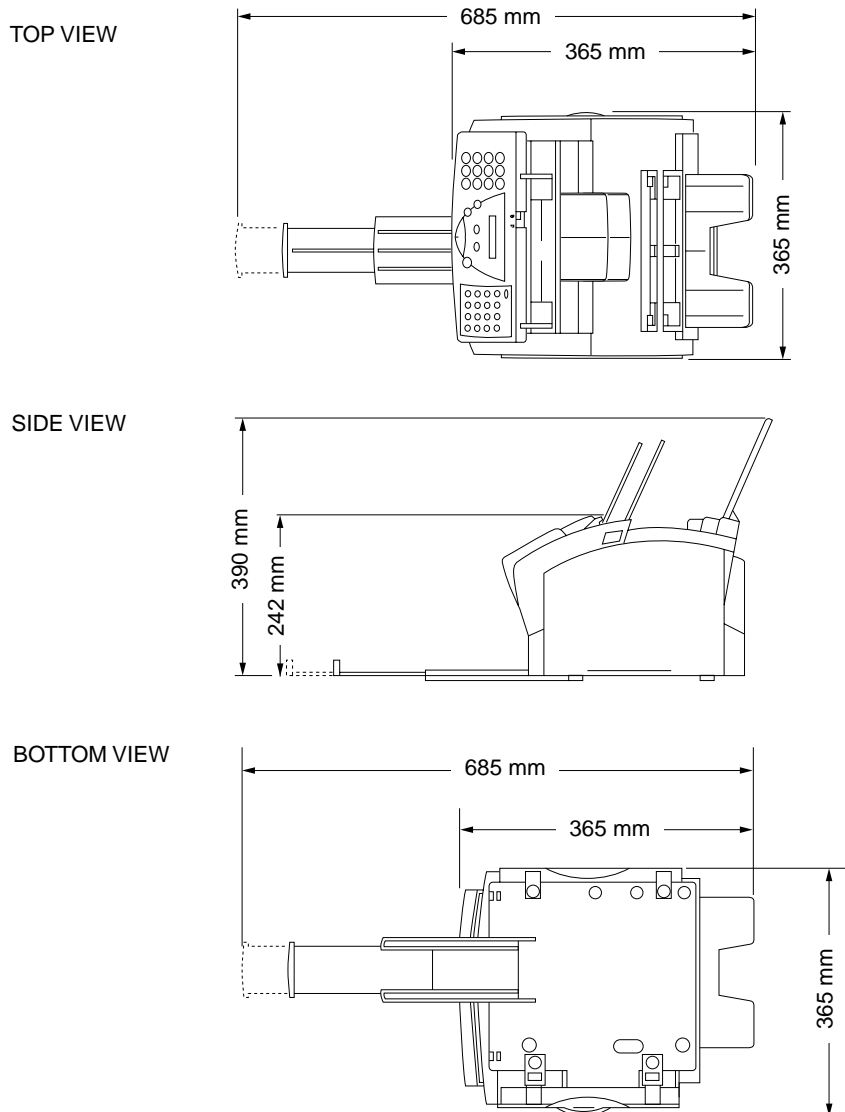

Figure 1-8 Dimensions



**This page intentionally left blank**

## 5. SAFETY & PRECAUTIONS

### 5.1 Personnel Hazards

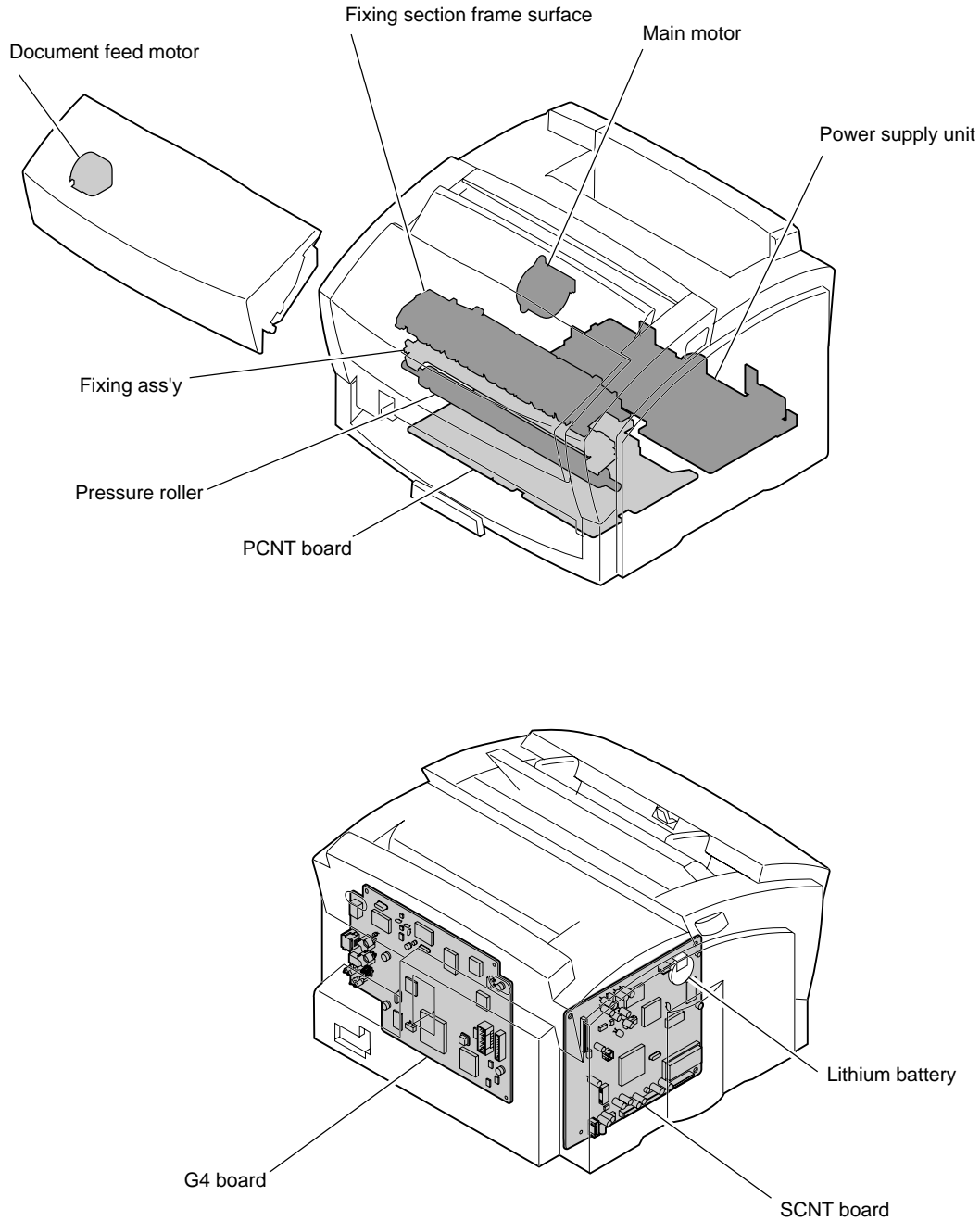
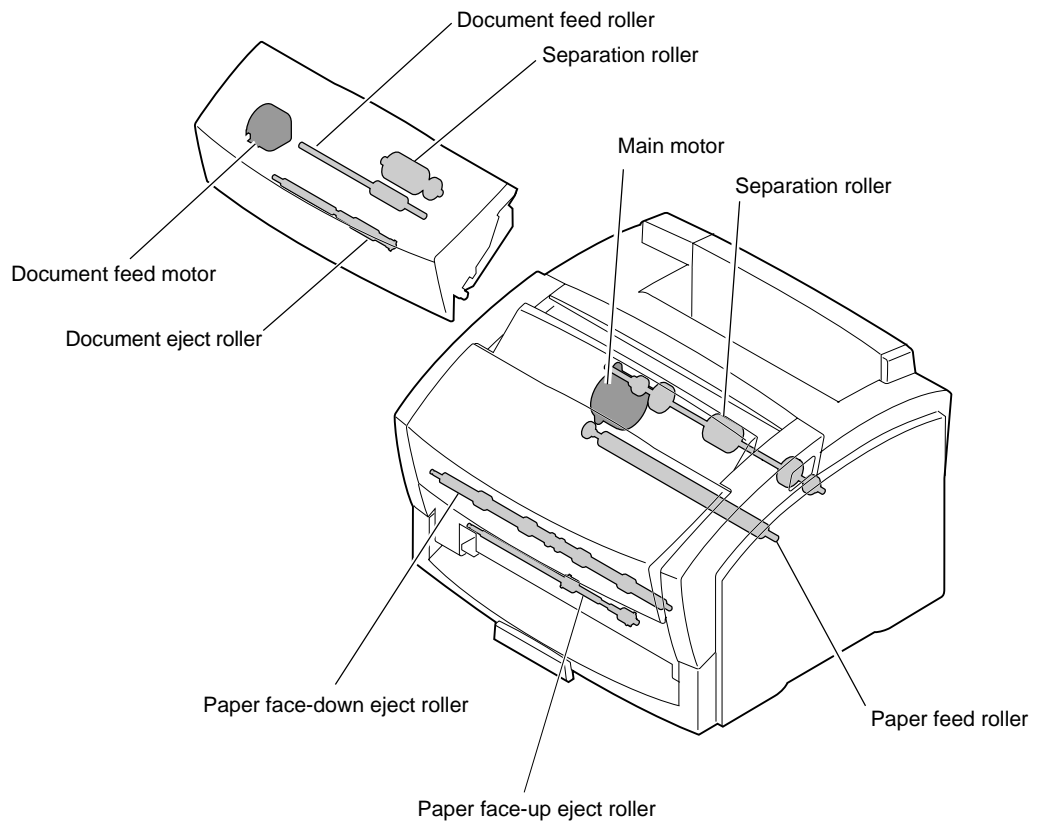

Figure 1-9 Personnel Hazards (1)



**Figure 1-10 Personnel Hazards (2)**

### 5.1.1 Electrical shock



---

#### Electrical shock hazard

- To prevent electrical shock, be sure to disconnect the power cord and ISDN line cable before disassembly.
  - Remove grounding wrist straps before servicing this unit while the FAX's power is on. Otherwise, electrical shock may occur.
- 



**NOTE**

---

#### Power supply unit

When power is supplied to this unit, 230 VAC will be supplied to the primary side.

#### Telephone line

The voltage supplied in the ISDN line is 34 VDC-42 VDC, as per ITU-T I.430 recommendations.

---

### 5.1.2 High-temperature parts



---

#### High-temperature warning

To prevent skin burns, disconnect the power cord and let this unit stand for at least 10 minutes to allow hot parts to cool.

---



**NOTE**

---

#### How to treat burns

Heat of about 122°F or more causes burns. Also, the longer the contact, the more severe the burn.

When treating a burn, the first minute after receiving the burn is the most important. Cool the burn immediately with cold running water. In case of a serious burn, seek medical attention immediately.

#### High-temperature parts

The parts which get hot during operation are indicated. For the location of these parts, refer to the figures.

(Ambient temperature 95°F (35°C) continuous copy operation)

Document feed motor (approx. 140°F (60°C))

Main motor (approx. 140°F (60°C))

Fixing section frame surface (approx. 203°F (95°C))

Fixing ass'y and pressure roller (approx. 338°F (170°C))

Power supply unit (Max. ~ 170.6°F (77°C))

PCNT board assembly (Max. ~ 190.4°F (88°C))

SCNT board assembly (Max.~153.7°F (67.6°C))

G4 board assembly (Max.~148.1°F (64.5°C))

---

### 5.1.3 Fire hazards



---

**Do not dispose in fire.**

Do not dispose of lithium batteries in fire. Doing so may rupture the battery and expose flammable materials.

Follow applicable local regulations when disposing of the SCNT board assembly's lithium battery.

**Fire hazard**

When using IPA or other solvents during servicing, heat or sparks from internal electronic circuits can ignite the solvent. Before using such solvents, be sure to turn off the power source and wait until the high-temperature parts cool. Use the solvent in a well-ventilated area.

---

### 5.1.4 Moving parts



---

**Moving parts**

To prevent mishaps due to moving or rotating parts during servicing, be sure to disconnect the power cord before disassembly.

---

### 5.1.5 LASER beams

This machine is classified as Class 1 laser product under EN60825: 1991 and EN60825-1: 1994. This means that the fax does not produce hazardous LASER radiation. However, observe the precautions below to avoid radiation by LASER beams during servicing involving disassembly.



#### Warning

If the LASER light gets in your eyes, it will damage the retina. Figure 1-11 is a LASER beam warning label which is placed on the LASER/scanner unit. Always remain within the contents of this manual when servicing, and do not carry out any other maintenance. Within the range of service work in this manual, you will not be exposed to dangerous LASER light.



Figure 1-11 LASER beam warning label



#### Disassembly Prohibited

Never disassemble or alter the printer section LASER/scanner unit. There is no servicing that requires you to disassemble the LASER/scanner unit.



NOTE

#### Safety Mechanism

There is a safety mechanism that electrically stops LASER emission and scanner mirror rotation when the front cover is opened and when the microswitch on the body frame has operated.

Also there is a safety mechanism that mechanically closes the shutter in the LASER/scanner unit to cut off the laser path, when the front cover is opened.

## 5.2 General Cautions

### 5.2.1 Unit cautions

## Safety Instructions

Read these safety instructions thoroughly before using your FAX-L260i, and keep them handy in case you need to refer to them later.



Caution

---

Except as specifically described in this user's guide, do not attempt to service the FAX-L260i yourself. Never attempt to disassemble the unit: opening and removing its interior covers will expose you to dangerous voltages and other risks.

---

- Always follow all warnings and instructions marked on the FAX-L260i.
- Use the FAX-L260i only on a sturdy, stable, level surface. If the unit falls, it could be seriously damaged.
- Do not use the FAX-L260i near water.
- The back of the FAX-L260i includes slots and openings for ventilation. To keep the FAX-L260i from overheating (which can cause it to operate abnormally and create a fire risk), take care not to block or cover these openings. Do not operate the unit on a bed, sofa, rug, or other similar soft surface, or near a radiator or other heat source. Do not place the FAX-L260i in a cupboard or cabinet or on shelves unless adequate ventilation is available.
- Operate the FAX-L260i only from the type of power source indicated on the unit's label. If you are unsure of the type of power available from your wall outlets, contact your local power company.
- Make sure the total amperage used by all devices plugged into the wall outlet does not exceed the ampere rating of the outlet's circuit breaker.
- Do not allow anything to rest on the power cord or place the FAX-L260i where the cord will be walked on. Make sure the cord is not knotted or kinked.

**Figure 1-12 Unit Cautions (1)**

- ❑ Do not insert objects of any kind into the slots or openings on the FAX-L260i's cabinet, as they could touch dangerous voltage points or short out parts, and result in fire or electric shock.
- ❑ Do not allow small objects (such as pins, paper clips, or staples) to fall into the FAX-L260i. If something does fall into it, unplug the unit immediately.
- ❑ Do not plug the power cord into an uninterruptible power supply (UPS).
- ❑ Always unplug the FAX-L260i before moving or cleaning it.
- ❑ Whenever you unplug the FAX-L260i, wait at least five seconds before you plug it back in.
- ❑ Keep the FAX-L260i away from direct sunlight, as this can damage it. If you have to place it near a window, install heavy curtains or blinds.
- ❑ Do not expose the FAX-L260i to extreme temperature fluctuations. Install the unit in a place with temperatures between 10° and 32.5 °C.
- ❑ Always unplug the FAX-L260i during thunderstorms.
- ❑ Before you transport the FAX-L260i, remove the toner cartridge.
- ❑ Always lift the FAX-L260i as shown below. Never lift it by its sheet feeder or other supports.

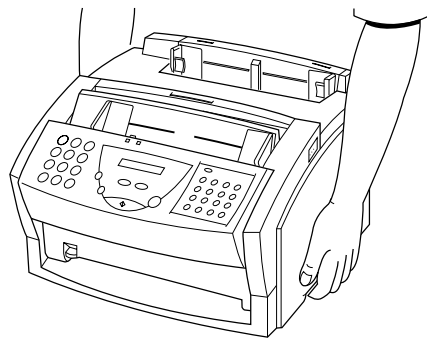

**Figure 1-13 Unit Cautions (2)**



## Choosing a Location for Your FAX-L260i

Before unpacking your FAX-L260i, follow these guidelines to choose an appropriate location for the unit.

- ❑ Put the FAX-L260i in a cool, dry, clean, well ventilated place:
  - Make sure the area is free from dust.
  - Make sure the location is not affected by extreme temperature fluctuations, and remains between 10° and 32.5 °C.
  - Make sure the area's relative humidity is always between 20% and 85%.
- ❑ Keep the FAX-L260i away from direct sunlight.
- ❑ If possible, place the FAX-L260i near an existing ISDN outlet, to allow for an easy connection of the ISDN line to the unit.
- ❑ Place the FAX-L260i near an electrical wall outlet that provides 200–240-volt AC (50–60 Hz) power.
- ❑ Do not plug the FAX-L260i into the same circuit as an appliance such as an air conditioner, electric typewriter, television, or copier. Such devices generate electrical noise that can interfere with your unit's ability to send or receive faxes.
- ❑ Set the FAX-L260i on a flat, stable, vibration-free surface that is strong enough to support its weight (about 8.6 kg).

Setting Up Your  
FAX-L260i

**Figure 1-14 Unit Cautions (3)**

## Connecting the Power Cord



Follow these guidelines when connecting your FAX-L260i to a power source:

- ❑ The FAX-L260i is intended for domestic use only and requires 200–240 V AC. Do not use it outside the country where it was purchased.
- ❑ Use only the power cord that came with the unit. Using a longer cord or extension cord can cause the FAX-L260i to malfunction.
- ❑ Unplug the unit only by pulling on the plug itself. Never pull on the cord.
- ❑ Do not plug the FAX-L260i into an outlet shared with an appliance such as an air conditioner, computer, electric typewriter, or copier. These devices generate electrical noise, which can interfere with the operation of the FAX-L260i.
- ❑ Make sure nothing is laying on the power cord, and that the cord cannot be walked on or tripped over.
- ❑ Do not overload the electrical outlet. Make sure the total amperage used by all the machines plugged into the outlet does not exceed the ampere rating of the outlet's circuit breaker.
- ❑ Do not plug the unit into an uninterruptible power supply (UPS).

Connect the power cord as follows:

1. Plug the supplied power cord into the power connector on the back of the FAX-L260i.

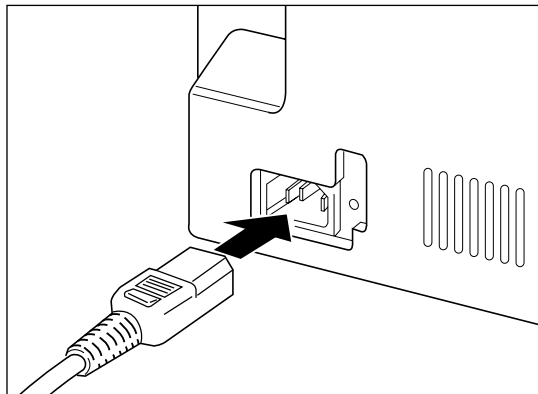
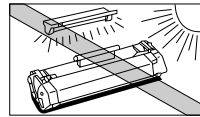

**Figure 1-15 Unit Cautions (4)**

## 5.2.2 Toner cartridge cautions

### a) Handling the toner cartridge

#### Handling and Storing Cartridges



- Do not expose the cartridge to direct sunlight or bright light for longer than five minutes.

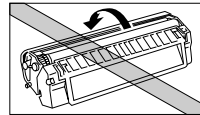

- Do not open the drum protective shutter on the cartridge. If the drum surface is exposed to light and damaged, print quality may deteriorate.

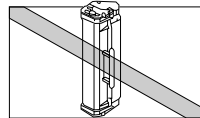

- Do not stand the cartridge on end, and do not turn it upside down. If toner becomes caked in the cartridge, it may prove impossible to free it even by shaking the cartridge.

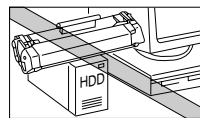

- Keep the cartridge away from computer screens, disk drives, and floppy disks. The magnet inside the cartridge may harm these items.

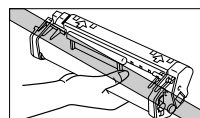

- Never touch the drum protective shutter. When holding the cartridge avoid touching the drum protective shutter with your hands.

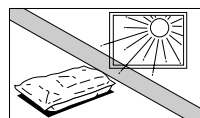

- Do not store the cartridge in direct sunlight.

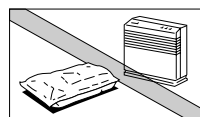

- Avoid locations subject to high temperature, high humidity, or rapid changes in temperature. Store the cartridge between 32° and 95° F (0° and 35° C).

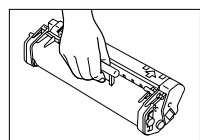

- Hold the cartridge as shown so that your hand is not touching the drum protective shutter.
- Store the cartridge in its protective bag. Do not open the bag until you are ready to install the cartridge in the unit.
- Save the protective bag. You may need to repack and transport the cartridge at a later date.
- Do not store the cartridge in salty air or where there are corrosive gases such as from aerosol sprays.
- Do not remove the cartridge from the FAX-L260i unless necessary.



Caution

DO NOT PLACE THE CARTRIDGE IN FIRE. TONER POWDER IS FLAMMABLE.

Figure 1-16 Precautions for Handling Cartridge

### b) Usage period of toner cartridge

The usage period for the toner cartridge is stamped on the label of its individual package. period lasts for 2.5 years from the date of manufacture. Using a cartridge after this period may reduce print quality.

## 5.3 Servicing Cautions

### 5.3.1 Damage from static charge

This unit contains contact sensors and printed circuit boards equipped with ROM, RAM, custom chips, etc. These electronic components are susceptible to damage caused by static charge.

When disassembling this unit, take care to prevent static charge.



---

#### Static electricity

Static charge can damage electronic components or alter their electrical characteristics. Even plastic tools and hands without grounding wrist straps can generate damaging static charge.

---

The following items are required to prevent static charge:

- A grounded, conductive mat
- Grounding wrist straps
- A cord with alligator clips to ground this unit's metal chassis

If you do not have any of the above on hand (during on-site servicing), follow the alternate measures below:

- Use a grounding bag to store and transport printed circuit boards and electronic devices.
- Avoid wearing silk or polyester clothing and leather-soled shoes. Wear cotton clothing and rubber-soled shoes instead.
- Avoid servicing this unit in a carpeted room.
- Before servicing this unit, touch this unit's grounded terminals to discharge any static charge.
- Wear grounding wrist straps and ground this unit's metal chassis.
- Always handle the circuit boards and devices along their edges. Do not touch the components and terminals with your fingers.



---

#### Shock hazard during power on

If servicing must be performed while this unit is turned on, do not wear any grounding wrist straps. This is to prevent electricity from passing through your body.

---

### 5.3.2 Scanner section

#### a) Contact sensor

- Handle contact sensors with care to prevent scratching or smudging of the scanning surface. Scratches or smudges can cause vertical stripes, etc., to appear on the scanned image.

#### b) ADF rollers

- Be careful not to scratch the ADF rollers. If the rollers are scratched, paper jams may result.

#### c) Lubrication points

- Document feed roller.

### 5.3.3 Printer section

#### a) Transfer charging roller

If skin, oil or, the like, gets on the sponge of the transfer charging roller, the rear side of the recording paper can be soiled, and blank patches can occur in printing.

During disassembly, hold the transfer charging roller by the shaft and gears at both ends.



REFERENCE

#### Cleaning method

If a printing defects occur, clean the transfer charging roller, as explained in *Chapter 3: Maintenance & Service*.

#### b) Fixing ass'y

If you get skin, oil, or the like, on the internal fixing film or pressure roller surface, the front or rear of the recording paper may be soiled, and fixing defects, and jams can occur.

During disassembly, hold the fixing ass'y by the plastic sections. Hold the pressure roller by the shaft, at both ends of the rollers.



REFERENCE

#### Cleaning method

If the fixing film or pressure roller is soiled, clean the transfer charging roller, as explained in *Chapter 3: Maintenance & Service*.

#### c) Lubrication points

Do not touch the greased parts of the outer periphery of the gear shaft and the gear teeth at the left side of the main frame. If you do, the grease (applied for smooth operation of the printer mechanism) will come off.



Use only specified grease.

If you use other grease, the grease may oxidize, and weaken plastic parts.



REFERENCE

If you accidentally touch a greased part and grease comes off, reapply the grease, *see the PARTS CATALOG (supplied separately)*.

**d) LASER/Scanner unit**

The LASER/scanner unit cannot be adjusted in the field so do not attempt to disassemble it.  
Never loosen or remove the screws on the LASER/scanner unit. Doing so might prevent satisfactory printing.

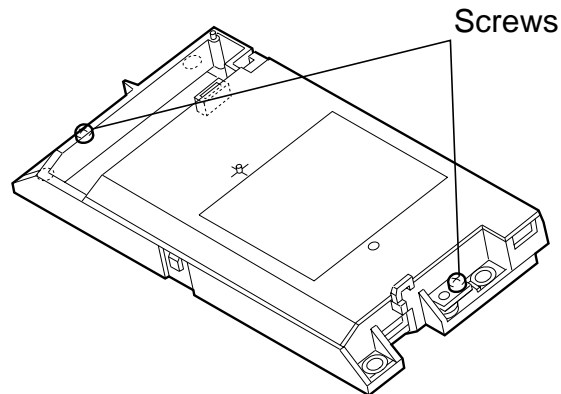

**Figure 1-17 Precaution for Handling LASER/scanner Unit**

**5.3.4 Paper feed section**

**a) Pick-up roller**

If, skin, oil or, the like, gets on the pick-up roller surface, misfeeding, jam, or multi-feeding can occur.  
During disassembly, hold the pick-up roller by the plastic sections.



**REFERENCE**

---

**Cleaning method**

If the printing defects occur, clean the pick-up roller, as explained in *Chapter 3: Maintenance & Service*.

---

### 5.3.5 Control boards

#### a) SCNT board

- The SCNT board stores the user data, service data, and other data. Therefore, when replacing the SCNT board, print out the stored data and then enter this data into the new SCNT board.



#### REFERENCE

---

The SCNT board replacement precaution is described in “5.4.3 SCNT board replacement precautions” on Page 1-37.

---

#### b) Power supply unit

- Current fuses FU101 on the power supply unit are directly attached. If these fuses must be replaced, we recommend replacing them together with the power supply unit.
- The power supply unit’s adjustable volume VR201, VR202 has been factory-adjusted. Service personnel are not to alter its setting.



---

Do not plug the unit into an uninterruptible power supply (UPS).  
Doing so may result in damage to the fixing ass’y.

---

## 5.4 Data-related precautions

The memory IC on the circuit board stores the user's registration data and values for various counters, etc., required for servicing. Although this data is normally retained in memory, it can be deleted by mistake. When handling this data during servicing, note the following precautions.

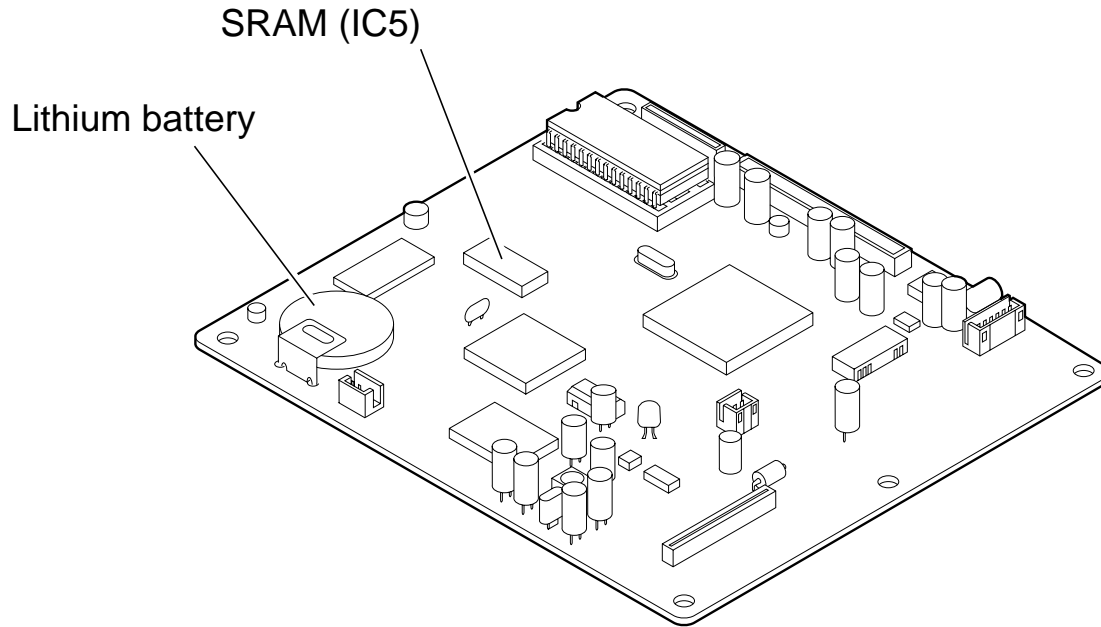

Figure 1-18 Backed up Devices

### 5.4.1 Data in the image storage memory (DRAM)

DRAM stores image data which was read other than by a direct transmission. It also acts as a buffer memory to store the image data received. If power is turned off, the memory clear list is printed automatically the next time the power is turned on. The user is thereby notified of the images that were erased from memory.



**NOTE**

---

#### Reception image data

This product is not equipped with image data backup, so that if the power supply is cut, data in memory reception will be lost.

When image data are set to be printed, they will be stored in the DRAM as memory reception images, and "REC'D IN MEMORY" will be displayed. If printing is disabled due to a fault in the printing section, transfer the stored reception image data to another fax machine.

---



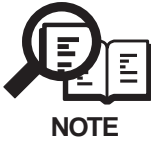

**Reception image data transfer**

When reception images cannot be output due to printer failure, etc., the image data can be transferred to another fax machine by using the reception image data transfer function. To transfer reception image data, set **SSSW #1 SW01 bit2 to "1"**, then follow the procedures below.

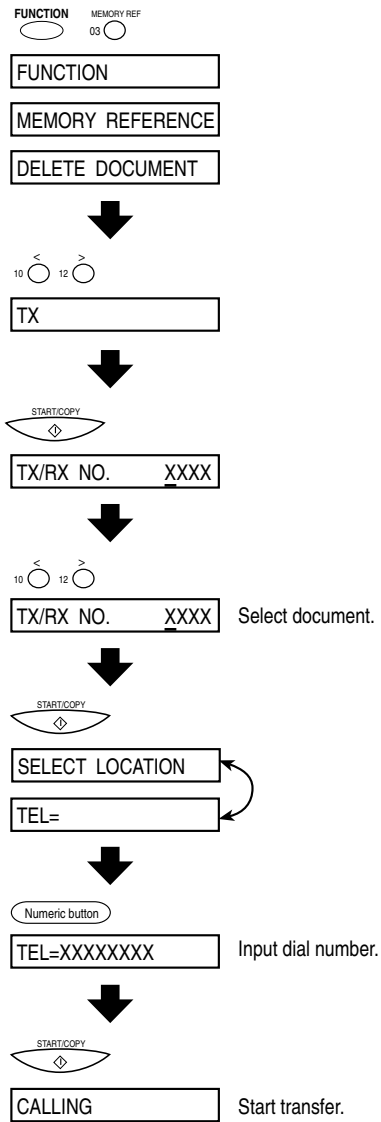

**Figure 1-19 Reception Image Data Transfer**



Be sure to return **SSSW #1 SW01 bit2 to "0"** after the reception image data transfer ends normally.

### 5.4.2 Data in the control processing memory (SRAM)

SRAM is backed up by a lithium battery. It can retain the stored data for 5 years after the power is turned off. SRAM stores the following data: All the data the user entered with the user data, the activity reports and other report-generating data, the redial data containing the redial destinations set with the Redial button, the servicing data set by repair personnel with the service soft switch. SRAM stores almost all of the data which can be entered or set.

These stored data can be checked with various reports.



**NOTE**

---

#### **Lithium battery life**

The lithium battery can last for over 5 years after the power is turned off.

When the power is on, the lithium battery's power is untapped. Therefore, the actual battery life can be much longer.

When the lithium battery becomes exhausted, "**DATA ERROR**" will be displayed after the power is turned off or on. When this happens, replace the lithium battery. Since the data in SRAM will be lost when the battery is replaced, it cannot be printed out.

After the lithium battery is replaced and the power is turned on, "**DATA ERROR**" will be displayed. Press the **START/COPY** button to discard the contents in SRAM and initialize it to the factory defaults.

---

### 5.4.3 SCNT board replacement precautions

Before replacing the SCNT board, print out all of the stored data.

The list which output the data that must be entered into the new SCNT board is listed below.

#### User list

- One-touch speed dialing list
- Coded speed dialing list
- Group dialing list
- User data list
- Activity report

#### Service list

- System data list
- ISDN data list
- System dump list



#### REFERENCE

---

To printout these list, see *Chapter 3: 7. SERVICE REPORT on Page 3-99*.

---



---

The service part SCNT board uses a jumper pin to close the lithium battery's circuit. To prevent battery depletion during shipping, only one prong of the jumper pin is covered with a jumper plug.

When replacing the SCNT board, re-attach the jumper plug so that it covers both prongs of the jumper pin and closes the circuit; the lithium battery can then be used for SRAM back-up.

If this procedure is omitted, there will be no battery back-up for the SRAM data.

After the new SCNT board is installed and the power is turned on, "**DATA ERROR**" will be displayed. Press the START/COPY button to discard the SRAM's irregular contents and initialize it to the factory defaults.

Then refer to the list that was printed out beforehand and enter the various data.

#### Replacing the ROM on the SCNT board

With this machine, it is necessary to print out all accumulated data, perform an "All clear", and set the "#5 TYPE" settings in the same way as when the SCNT board is replaced, even if only replacing the SCNT board's ROM.

---

**Operation flow after replacing SCNT board**

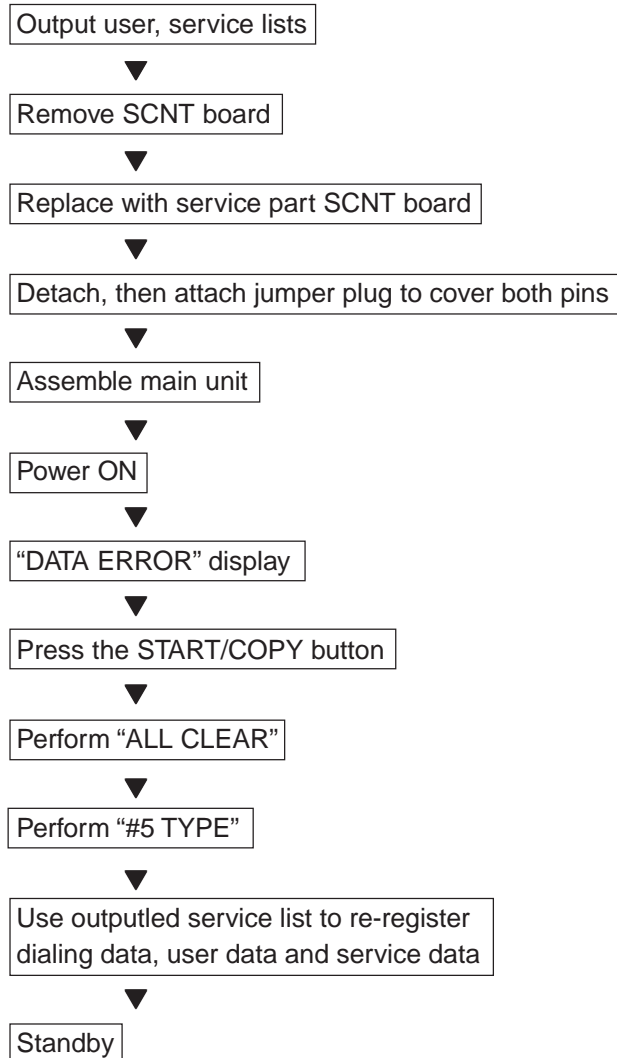

### 5.4.4 Data initialization through service operation

All the data can be initialized with the service data #8 clear operation.



**REFERENCE**

For details on the initialization procedure and the data that is erased, see *Chapter 3: 5.2 Service Data Settings on Page 3-54*.



**NOTE**

**"All clear" when nothing works.**

On a rare occasion, the display may go blank and all the buttons may stop working.

Severe electrical noise and static can cause problems as well. In such a case, use the **"All clear"** feature.

After installing the unit for the first time and connecting the power cord, execute **"All clear."**

Also, after an **"All clear,"** we recommend that you set the country type to suit the communication standard used in your country. Below is the procedure for performing All clear and type setting operation.

**ALL CLEAR**

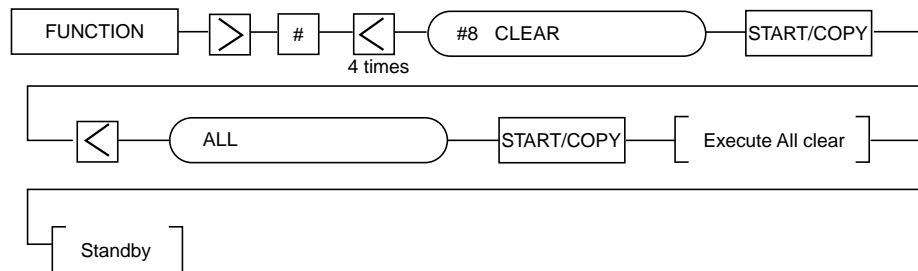

**TYPE SETTING**

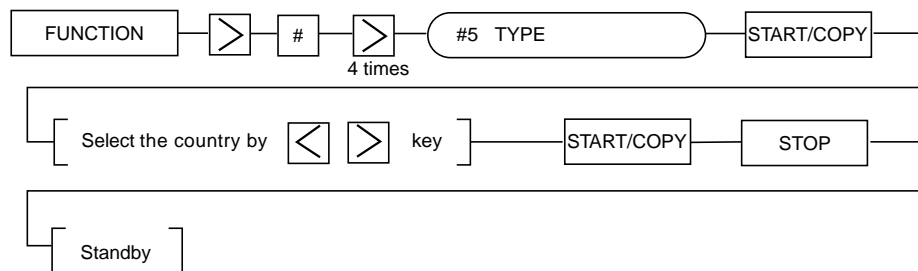

**Figure 1-20 All Clear and Type Setting**



While waiting to return to the ready state after executing **"All clear"**, please do not press the STOP button. Doing so may cause a malfunction afterwards.

## 5.5 Protective Mechanism

### 5.5.1 Data battery backup function

If there is a power outage or if the power is turned off, the data stored in the control memory is retained since the lithium battery function as a data battery backup.



For details on the backed up data, see *Chapter 1: 5.4 Data related precautions* on Page 1-34.

#### REFERENCE

### 5.5.2 Overcurrent protection

This machine is provided with an overcurrent with built-in fuse, to prevent abnormal rises in temperature if an overcurrent flows to the motors and power supply due to driver IC trouble, software lockup and short circuit.

Protected Parts	Safety Measures
Document feed motor	IC protector (FU401) on PCNT board
Main motor	IC protector (FU401) on PCNT board
Power supply unit	Glass-tube current fuse (FU101 : 250V) overcurrent protection circuit thermistor (TH101)
Fixing ass'y	Thermal fuse, thermistor

### 5.5.3 Lightning protection

The fax unit's electrical components are protected from abnormal voltage caused by lightning.

Protected Component	Safety Device
Power supply unit	Varistor (VZ101) located at the primary side of the power supply unit discharge a voltage of more than
G4 board ass'y	The arrester (VZ1~4) positioned on the primary side of the G4 board discharges via the ISDN line more than 1000V of voltage applied between the line and the line. More than 500V applied between the line and the GND is also discharged via the power cord.



#### When protection is not possible

The G4 board sometimes may not be protected even by the protection circuits if lightning strikes the ISDN line.

#### NOTE

### 5.5.4 Power leakage protection

The AC line, ISDN line, and metal parts of the fax unit are completely insulated. The fax unit has a grounded power cord to prevent electrical shock. If power leakage does occur, use the fax unit only with a grounded electrical outlet supplying the proper voltage.

## **6. QUALIFICATION REQUIRED FOR INSTALLATION WORK**

The qualifications for installation must satisfy local laws and regulations.

**This page intentionally left blank**



# ***Chapter 2***

## ***Technical Reference***



# 1. DRIVE/ELECTRICAL SYSTEM LAYOUT

This machine is divided into three mechanisms: scanner section, paper supply section and printer section.

In the scanner section, the document feed motor drives the document feed rollers and separation rollers to feed the document from the document feed tray to the document eject slot at the front of the machine. The document is scanned by the contact sensor located along the document feed path.

In the paper supply section, the main motor in the printer section is used to drive the paper pickup roller, which separates one sheet at a time from multiple sheets set on the recording paper rest at the rear of the machine, and feeds the recording paper to the printer section.

In the printer section, the main motor drives the gears and rollers to print the image scanned from the document onto the recording paper fed from the papers supply section, which is then ejected. The user can choose to eject the printed paper either face up or face down.

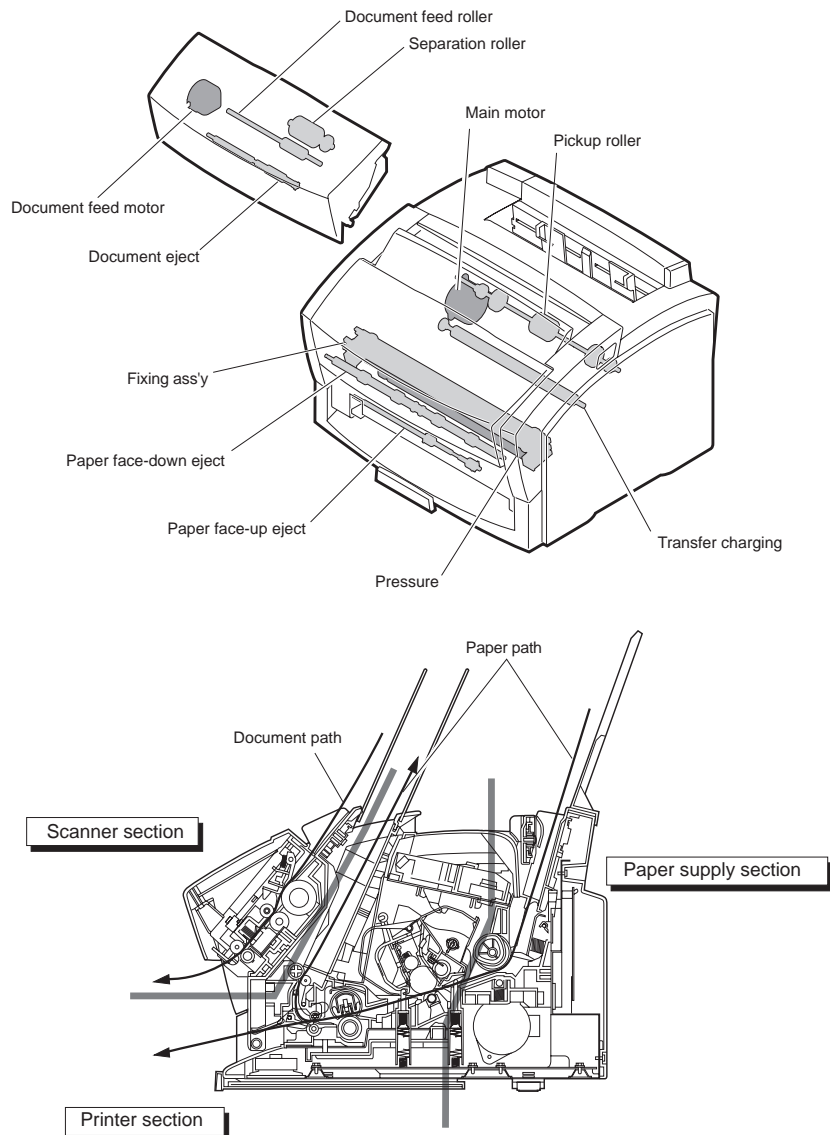
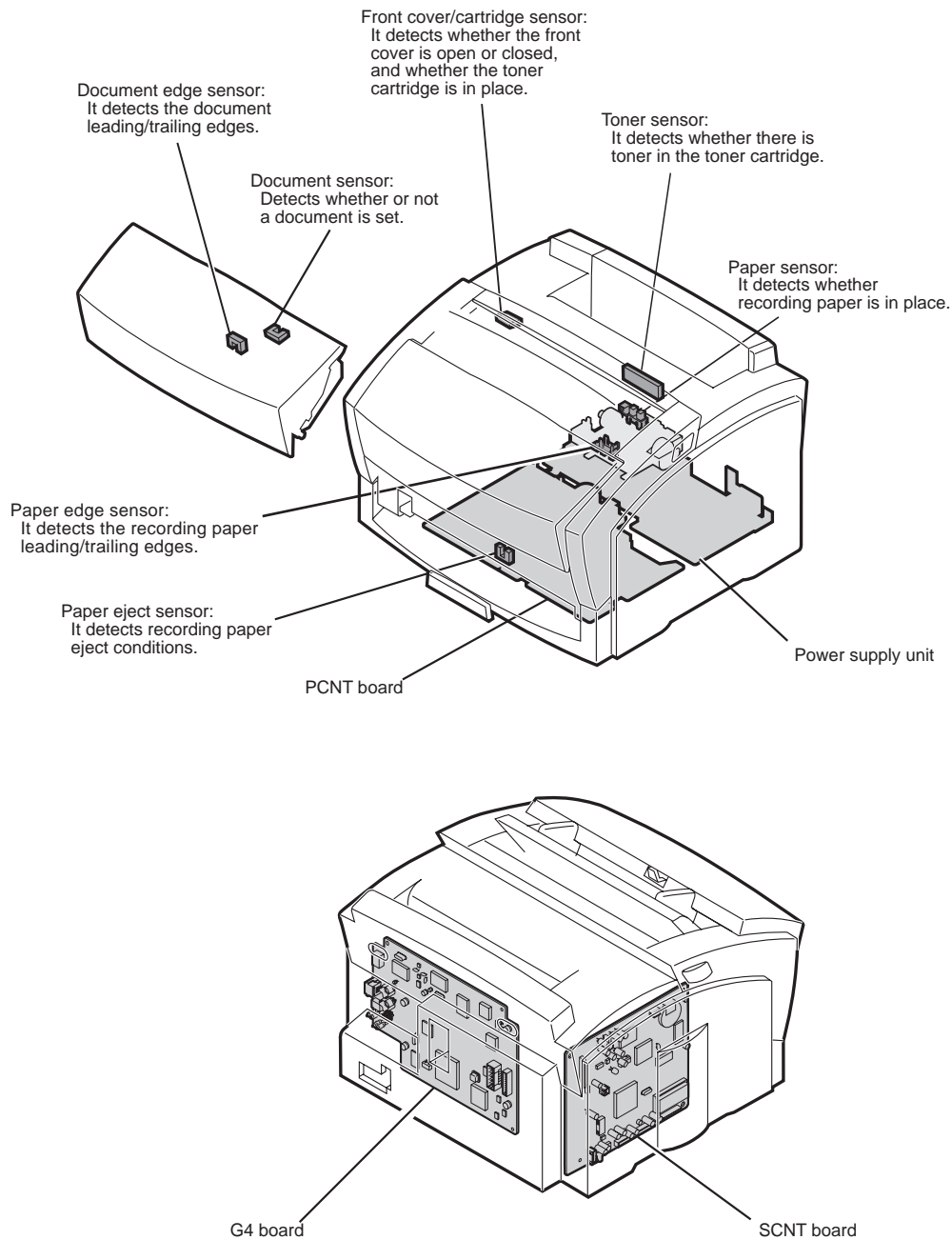

Figure 2-1 Drive System Layout

The following six printed circuit boards are located in this machine:

- SCNT board that controls the entire system
- G4 board that controls the communication section
- PCNT board that generates high voltage for the printer
- OPCNT board that controls the operation panel's buttons and LCD.
- A power supply unit is also located in this machine.

The seven sensors shown below detect the status of the machine.



**Figure 2-2 Electrical System Layout**

**This page intentionally left blank**

## 2. SCANNER MECHANISM

The scanner section scans documents that are to be sent or copied.

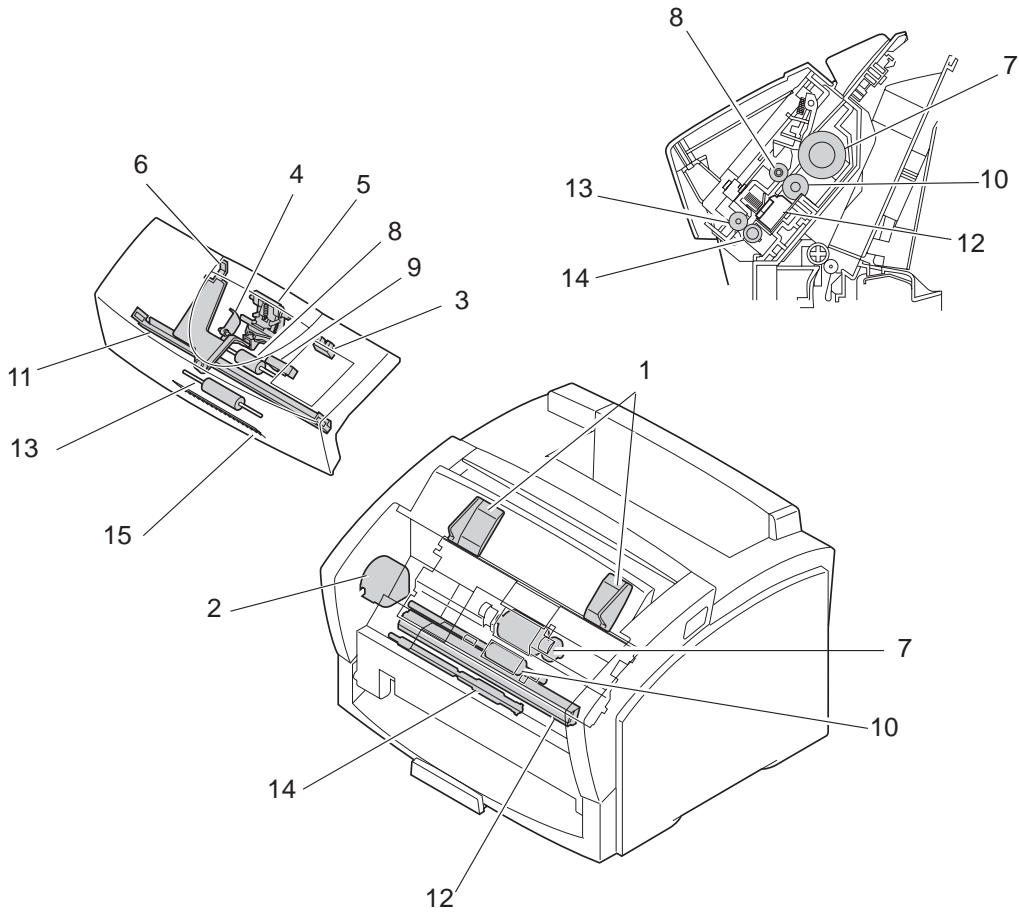

Figure 2-3 Scanner Section

**Names and functions of parts:**

**1. Paper Guide**

When properly adjusted to the width of the documents, the guide will hold the documents in the horizontal direction to prevent them from skewing when fed.

**2. Document Feed Motor**

This motor drives all the rollers in the scanner section.

**3. Document Sensor (DS)**

This sensor uses an actuator to detect the presence of documents to be scanned, and sends that information to the SCNT board by way of the gate array in the operation panel unit.

**4. Document Stopper**

This stopper is located to the side of the separation rollers, and prevents documents from entering too far inside the scanning section. This stopper is located here to improve document loading and prevent double feeding or non-feeding due to defective loading of documents.

**5. Separation Guide**

Separates the documents to prevent double-feeding.

**6. Document Feed Lever**

→ See Page 2-6

This lever switches between automatic document feed and manual document feed. Damage to the document caused by the separation roller can be minimized by switching to the manual document feed position when sending single sheets such as thick-stock paper or photographs.

**7. Separation Roller**

This roller uses differences in the coefficients of friction of the separation guide, document and separation roller to separate each of the sheets in a multiple-page document.

**8. Upper Document Feed Roller**

→ See Page 2-6

When the separation roller starts to rotate, the upper document feed roller raises the document stopper so that documents can be fed.

**9. Document Edge Sensor (DES)**

Using an actuator, the DES detects the edge of a document just before it reaches the contact sensor, and sends this information to the SCNT board.

**10. Document Feed Roller**

This roller feeds documents to the contact sensor after they are separated by the separation roller.

**11. White Sheet**

This white sheet is used as a whiteness reference when pre-scanning documents.

**12. Contact Sensor**

Scans the image information from the document, converts it to serial data, and transmits it to the SCNT board as an electrical signal. The contact sensor has a scanning resolution of 300 dpi.

**13. Upper Document Eject Roller**

Holds the document between the document eject rollers, and then ejects it.

**14. Document Eject Roller**

This roller ejects documents fed from the document feed roller.

**15. Static Eliminator Brush**

Removes static electricity which may have built up on the document in the scanning process, and guards against roller jams.



**NOTE**

---

**Initializing the upper document feed roller**

When the separation roller starts to rotate, the position of the upper document feed roller is simultaneously initialized to raise the document stopper. Initialization is carried out when the power is turned ON, when documents are inserted and when documents are ejected.

**Document feed lever**

Switching between automatic document feed and manual document feed is carried out by the document feed lever above the left side of the LCD. During automatic document feed, documents are gripped between the separation guide and the separation roller. Switching the lever to manual document feed raises the separation guide and frees it from the document. Manual document feed can therefore minimize the possibility of damage caused by pinching between the separation guide and separation roller when feeding documents such as thick-stock paper or photographs. However, because document separation does not occur in manual document feed mode, only one sheet at a time may be loaded. Loading multiple sheets will result in double feed.

**Document Jam Detection**

There are two types of document jams which may occur:

**a) Feed jam**

Occurs when the document edge sensor cannot detect the document's leading edge within 15 seconds after the start of document separation.

**b) Eject jam/document too long**

Occurs when the document edge sensor cannot detect the document's trailing edge within one meter of feeding after the document's leading edge is detected.

When one of these types of jams occurs, all data which have been read and stored in memory (except pages that have already been completely transmitted or copied) are erased.

---



**This page intentionally left blank**

### 3. PAPER SUPPLY SECTION

The paper supply section separates the sheets of recording paper loaded in the sheet feeder and feeds them to the printer section one sheet at a time.

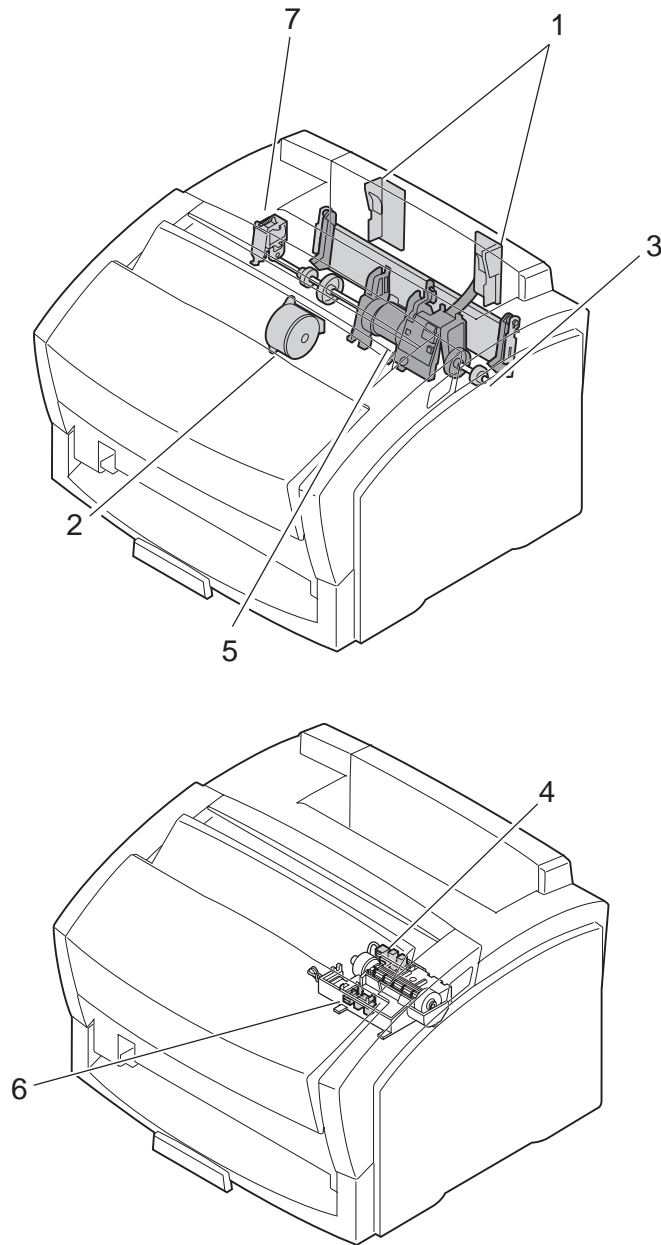

Figure 2-4 Paper Supply Section

**Names and functions of parts:**

**1. Paper Guide**

This guide can be adjusted to the width of the loadable recording paper sizes. It prevents the recording paper from skewing during recording by accurately aligning the paper width.

**2. Main Motor**

This motor drives all the rollers in the paper supply section.

**3. Lifting Plate**

The lifting plate that was held down by the pickup roller is lifted up during paper feeding, and the recording paper loaded on the lifting plate contacts the pickup roller to be separated.

**4. Paper Sensor (PS)**

This sensor uses an actuator to detect the presence of recording paper in the sheet feeder.

**5. Pickup Roller**

The pickup roller has a semi circular roller. This roller is rotated once, and operating together with the lifting plate, feeds the paper one sheet at a time.

**6. Paper Edge Sensor (PES)**

This sensor uses an actuator to detect the leading edge of recording paper and sends detection information to the SCNT board. It is located under the pickup roller.

**7. Pickup Solenoid**

This solenoid controls rotation of the pickup roller. When the main motor is activated to begin paper feeding, the pickup solenoid releases the pickup roller. When the pickup roller picks up a sheet of recording paper and rotates one full turn, the solenoid locks the pickup roller again.



**NOTE**

---

**Paper Feed Jam Detection Retry Function**

Because the recording paper on this machine is loaded upright, the paper is sometimes difficult to feed when there is little recording paper left or the recording paper curls. For this reason even if the paper edge sensor does not detect the leading edge of the recording paper within 3.5 seconds after the pickup solenoid releases the pickup roller the machine tries to repeat the same operation before judging that a jam has occurred. If the paper edge sensor still cannot detect the leading edge of the recording paper, a paper feed delay jam is detected.

---



**NOTE**

**Paper feed jam detection**

There are two types of paper jam which may occur:

**a) Paper feed delay jam**

The paper feed delay jam occurs if the paper edge sensor does not detect the leading edge of the recording paper within 7.0 seconds (including paper feed jam detection retry time) after the pickup solenoid releases the pickup roller.

**b) Paper feed stationary jam**

The paper feed stationary jam occurs if the trailing edge of the recording paper is not detected within 11.7 seconds after the paper edge sensor detects the leading edge of the recording paper.

When either of these jams is detected, the message “**CLEAR PAPER JAM**” is displayed. If this machine is receiving, the data is received via memory reception. If the machine is copying from memory, the image data in memory will be cleared.

To clear a paper feed jam, open the front cover and remove the jammed recording paper from inside. When the front cover is closed, the recording paper is automatically output. When jammed recording paper is removed from inside without opening the front cover, open and close the front cover once to reset the printer.

**Paper size error**

The machine does not have a paper size sensor. It recognizes the paper sizes (Letter, A4, and Legal) according to the user data setting.

A paper size error occurs if the specified paper size is different from the size of the paper placed in the sheet feeder when one page is actually printed. In this case, a message “**CHECK PAPER SIZE**” appears on the display, the ALARM lamp blinks, and the following operation is carried out.

**If the specified paper length is greater than the actual paper length:**

When the received document comprises one page, one sheet is printed and operation ends. The error message remains displayed, so clear the error message. When the received document comprises two or more pages, it is received in memory from the second sheet onward. Printing automatically starts from the 2nd sheet onwards after the error is corrected.

**If the specified paper length is less than the actual paper length:**

Regardless of whether the document consists of only one sheet or two or more sheets, it will be received in memory.

The document is automatically output after the error is corrected.

To correct the error, either match the user data setting with the actual recording paper, or match actual recording paper with the user data setting.

The paper size error does not occur during copying.

---

**This page intentionally left blank**

## 4. PRINTER SECTION

The LASER beam printer engine comprises the following sections.

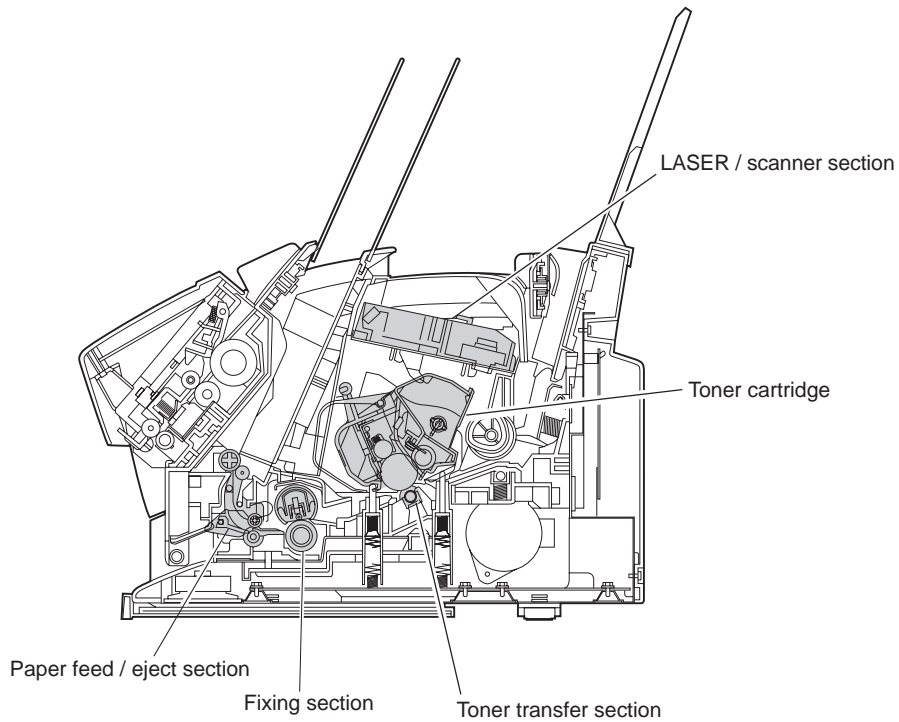

**Figure 2-5 Printer Section**

#### **4.1 LASER/Scanner Section**

→ See Page 2-14

This section comprises a LASER unit, cylindrical lens, 4-faced polygon mirror, scanner motor, imaging lens, reflection mirror and BD unit. The LASER is driven in accordance with the LASER drive signals that are sent from the PCNT board. This LASER light passes through the cylindrical lens to fall on the 4-faced polygon mirror that is rotating at a fixed speed. The LASER light is reflected from the 4-faced polygon mirror and passes through the imaging lens, and reflects from the reflection mirror to scan the photosensitive drum in the toner cartridge.

#### **4.2 Toner Cartridge**

→ See Page 2-14

This cartridge comprises the primary charging roller, developing cylinder, photosensitive drum, cleaner blade, and toner.

The LASER beam from the LASER/scanner section forms a latent static image on the photosensitive drum that is charged by the primary charging roller. The photosensitive drum rotates inside the toner cartridge, and rotation of the developing cylinder causes toner to adhere to the photosensitive drum to form a visible image which is then transferred to the recording paper at the toner transfer section. Residual toner is then removed from the surface of the photosensitive drum by the cleaning blade.

#### **4.3 Toner Transfer Section**

This section comprises the transfer charging roller and the static eliminator. The recording paper passes between the photosensitive drum and the transfer charging roller, and the transfer charging roller is charged with a charge opposite to that of the toner to transfer the toner on the photosensitive drum to the recording paper. The charge on the rear side of the recording paper is then removed by the static eliminator.

#### **4.4 Fixing Section**

→ See Page 2-15

This section comprises the fixing ass'y and pressure roller. The fixing section on this machine is an on-demand system that uses fixing film with low thermal capacity.

The toner that was transferred to the recording paper at the toner transfer section is fused to the paper and fixed as a permanent image.

The fixing ass'y has a built-in fixing heater and thermistor. The fixing temperature is controlled by the printer controller on the PCNT board.

## 4.5 Paper Feed/Eject Section

→ See Page 2-16

After toner is fixed in the fixing section, the recording paper is fed to either the face-up delivery slot or the face-down delivery slot that is switched by the flapper. The user selects the setting of the flapper by the paper delivery selector at the bottom left of the front panel.

All rollers from paper feed through paper ejection are driven by the main motor.

### 1. Paper eject sensor

An actuator is used to detect the leading edge of the recording paper that is fed towards the ejected paper. The detection information is sent to the SCNT board.

### 2. Flapper

This flapper switches the direction in which the recording paper is ejected after toner is fixed.



NOTE

---

#### BD Malfunction

If the total number of sheets printed after turning the power ON is four or more, and BD is out of the BD cycle for 2.0 seconds or more during laser drive while the scanner motor is rotating at fixed speed, the printer controller judges this to be a BD malfunction.

#### Scanner Motor Malfunction

If the predetermined speed of rotation is not reached within 3.0 seconds of start of scanner motor rotation, the printer controller detects a scanner motor malfunction and stops the scanner motor.

---



---

The LASER/scanner unit contains parts that require adjustment that must be adjusted. Never disassemble the LASER/scanner unit.

---



NOTE

---

#### No-toner detection

The no-toner state is detected by the toner sensor (magnetic sensor) located on the pickup roller shaft. If a toner cartridge is installed, the toner sensor touches the side of the cartridge. The part of the cartridge which the toner sensor touches is made thinner to increase the sensor output. When the toner sensor detects no toner, the sensor output goes low.

#### Cartridge detection

A microswitch detects cartridge presence and front cover open/closed. The microswitch is structured so that it is shorted only when the cartridge is loaded and the front cover is closed.

---





#### Drum cover shutter

If the photosensitive drum is subjected to strong light, optical memory can cause dropout areas or black bands to occur. To prevent the photosensitive drum from strong light, a drum cover shutter is attached. Do not open this cover unless absolutely necessary.



#### NOTE

#### Fixing Heater Malfunction

The printer controller on the PCNT board detects a fixing heater malfunction in the following instances.

- a) When a temperature of 100°C or more is not detected within 15 seconds after the fixing heater begins heating toward the normal preset target temperature
- b) When a fixing unit temperature of 195°C or more continues for 150m seconds
- c) When a temperature of 20°C or more is not detected even though the power is supplied for 0.5 seconds during printing or warming up
- d) When a temperature of less than 0°C is detected for 150m seconds during fixing heater control
- e) When the fixing heater temperature falls to 90°C or lower for 3 seconds during printing

When a fixing heater malfunction is detected, this machine shuts off the power supply to the fixing heater, stops the main motor, scanner motor and high-voltage systems, and generates a printer error.

#### Paper eject jam detection

There are two types of paper eject jam which may occur.

##### a) Paper eject stationary jam

A paper eject stationary jam occurs when the paper eject sensor detects the paper between 3.3 and 4.7 seconds after the paper edge sensor detects the trailing edge of the paper.

##### b) Paper eject delay jam

A paper eject delay jam occurs if the paper eject sensor detects “no paper” between about 5 seconds after the paper edge sensor detects the leading edge of the paper and about 2.5 seconds after paper edge sensor detects the trailing edge of the paper. Fixing unit windup jams are also detected by this method.

When either of these jams are detected, “**CLEAR PAPER JAM**” is displayed. If the jam occurs during reception, the data is received in memory. If it occurs in memory copy mode, the image data in memory is cleared.

To clear a paper eject jam, open the front cover, and remove the jammed paper. Output resumes automatically when you close the front cover. If you remove the jammed paper without opening the front cover, open and close the front cover once to reset the printer.

When a fixing unit windup jam occurs, remove the delivery cover to access the jammed paper, then remove the jam.

### Paper delivery slot switching

The paper delivery slot can be switched by the paper delivery selector located at the bottom left on the front of the machine. After fixing, the paper is fed to the flapper, which guides it to one of two delivery slots. When the paper delivery selector is set to the up position, the flapper is lowered to guide paper to the face-down delivery slot. The paper is delivered face-down, so that pages are stacked in numeric order.

When the paper delivery selector is set to the down position, the flapper is raised to guide paper to the face-up delivery slot.

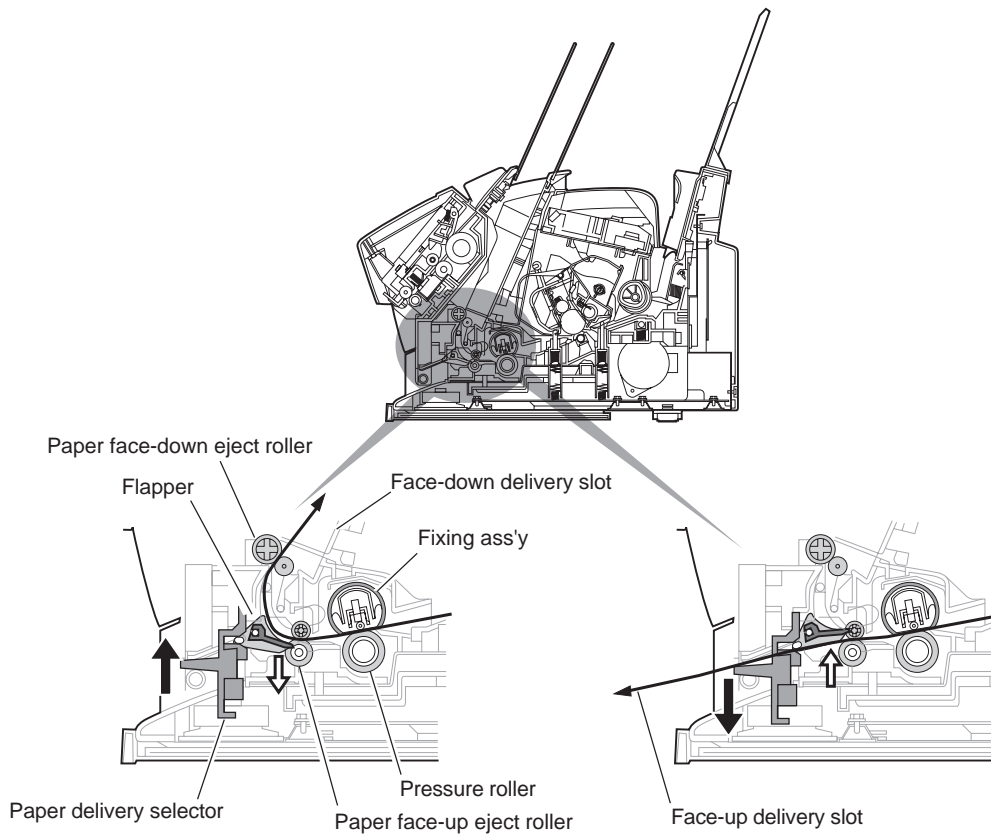

Figure 2-6 Paper Delivery Slot Switching

---

# 5. ELECTRIC CIRCUIT

## 5.1 Component Block Diagram

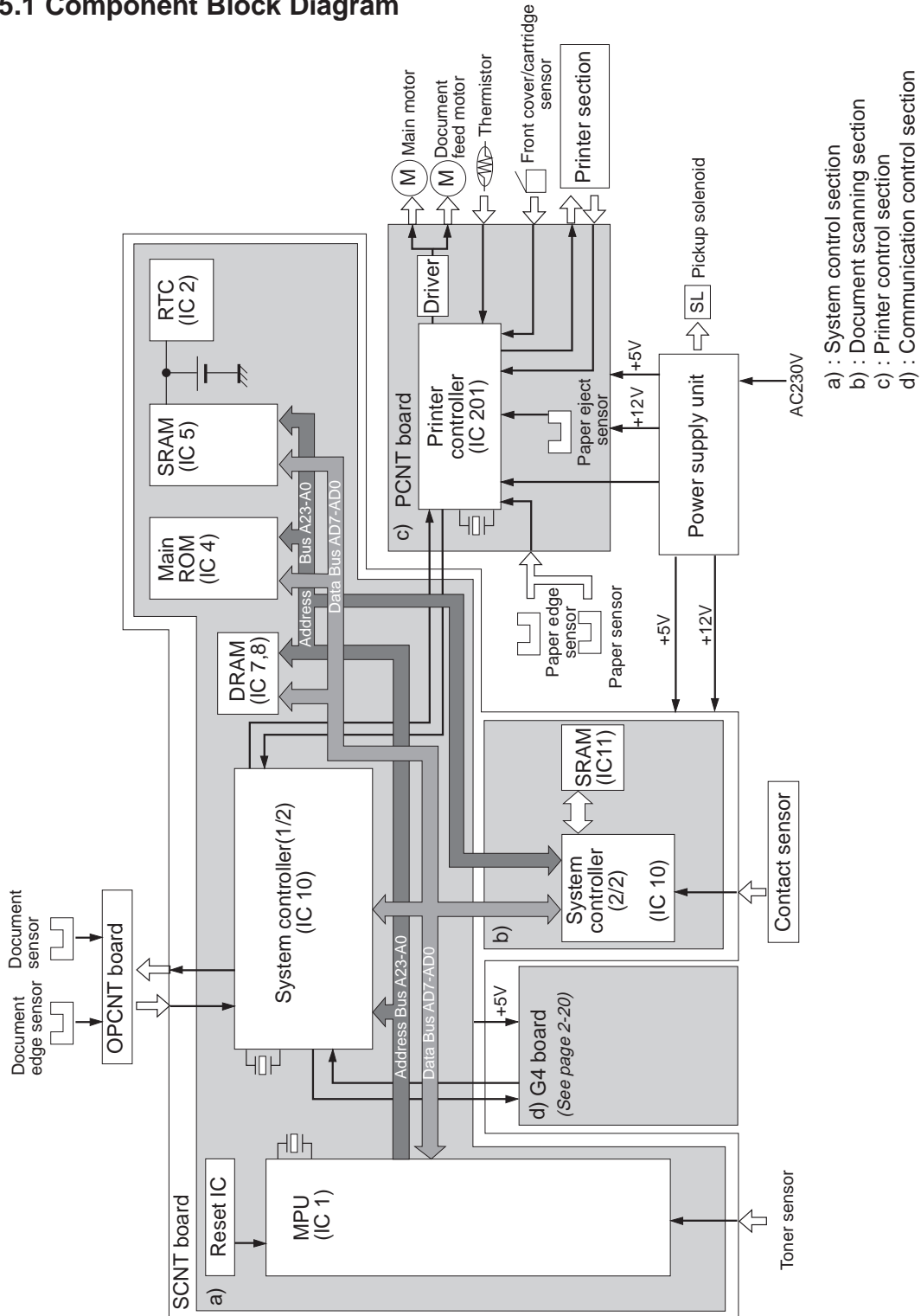

Figure 2-7 Component Block Diagram

## **5.2 Circuit Board Components**

### **a) System control section**

The system controller is made up of the following components, and controls the entire fax system.

#### **a-1) MPU (Micro Processor Unit) (IC1)**

The main functions of the NEC  $\mu$ PD70433GJ-16-3EB MPU are as follows:

- 16 bit CPU
- 24 bit address bus
- 8 bit data bus
- DMA control
- A/D converter
- Software CODEC
- Interrupt control unit

#### **a-2) System controller (IC10)**

The system controller is a gate array for controlling MPU peripheral devices. The main functions of the system controller are as follows:

- Printer resolution conversion (Smoothing)
- LBP video interface

The LBP video interface transfers print signals to or from the printer controller and sends them to the MPU. The interface transmits an image signal (nVDO) and a vertical sync signal (nTOP) to the printer section, receives a horizontal sync signal (nBD) and printer section status from the printer section and transfers them to the MPU.

- OPCNT serial interface
- DRAM/SRAM controller
  - Controls DRAM/SRAM read/write and refreshing.
- Document feed motor control
- Reduction in vertical scanning
- Recording decoder

#### **a-3) RTC (Real Time Clock) IC (IC2)**

A SII S3510ANFJ-TB is used as the RTC. The RTC IC is backed up by lithium battery, and counts the date and time.

#### **a-4) Main ROM (IC4)**

This 8 Mbit ROM contains the control programs (e.g. operation panel, scanner and communications section etc.) for this fax.

#### **a-5) SRAM (IC5)**

This 256 kbit SRAM is backed up by lithium battery. SRAM holds data registered for system control and communications management information.

#### **a-6) DRAM (IC7, IC8)**

This 16 Mbit is used as memory for storing image data, and as an MPU work area.

**b) Document scanning section**

**b-1) System controller (IC10)**

The system controller IC include image processing function (UHQ) are as follows:

- Serial-to-parallel conversion
- A/D conversion

Input signals from the contact sensor are A/D converted.

- ABC(Auto Background Control)

Sets the slice level for each scan line.

- Edge enhancement processing
- Binaryzation processing
- Halftone processing

**b-2) SRAM (IC11)**

Used as a shading data buffer or an edge enhancement processing buffer.

**c) Printer control section (PCNT board)**

The printer control section is made up of the printer controller IC (IC 201). The printer controller IC is a microcomputer that incorporates a Fujitsu MBCU34102-104 8kbyte ROM and a 256byte RAM. The ROM contains printer control software to control LBP operations.

The printer control section receives commands from the system controller IC and controls paper pickup and loading, the fixing heater, the high voltage required for primary charging, development, and transfer, and the LASER/scanner unit.

The printer control section transfers the signal received from the printer section to the system controller IC as printer status.

The printer controller IC has the following other functions:

- Main motor control
- Fixing heater control
- Fixing heater temperature detection
- BD signal detection
- LASER drive control
- Pickup solenoid control
- APC control
- Scanner motor, fixing ass'y, or BD failure detection
- Control of high-voltage power supply

d) Communication control section

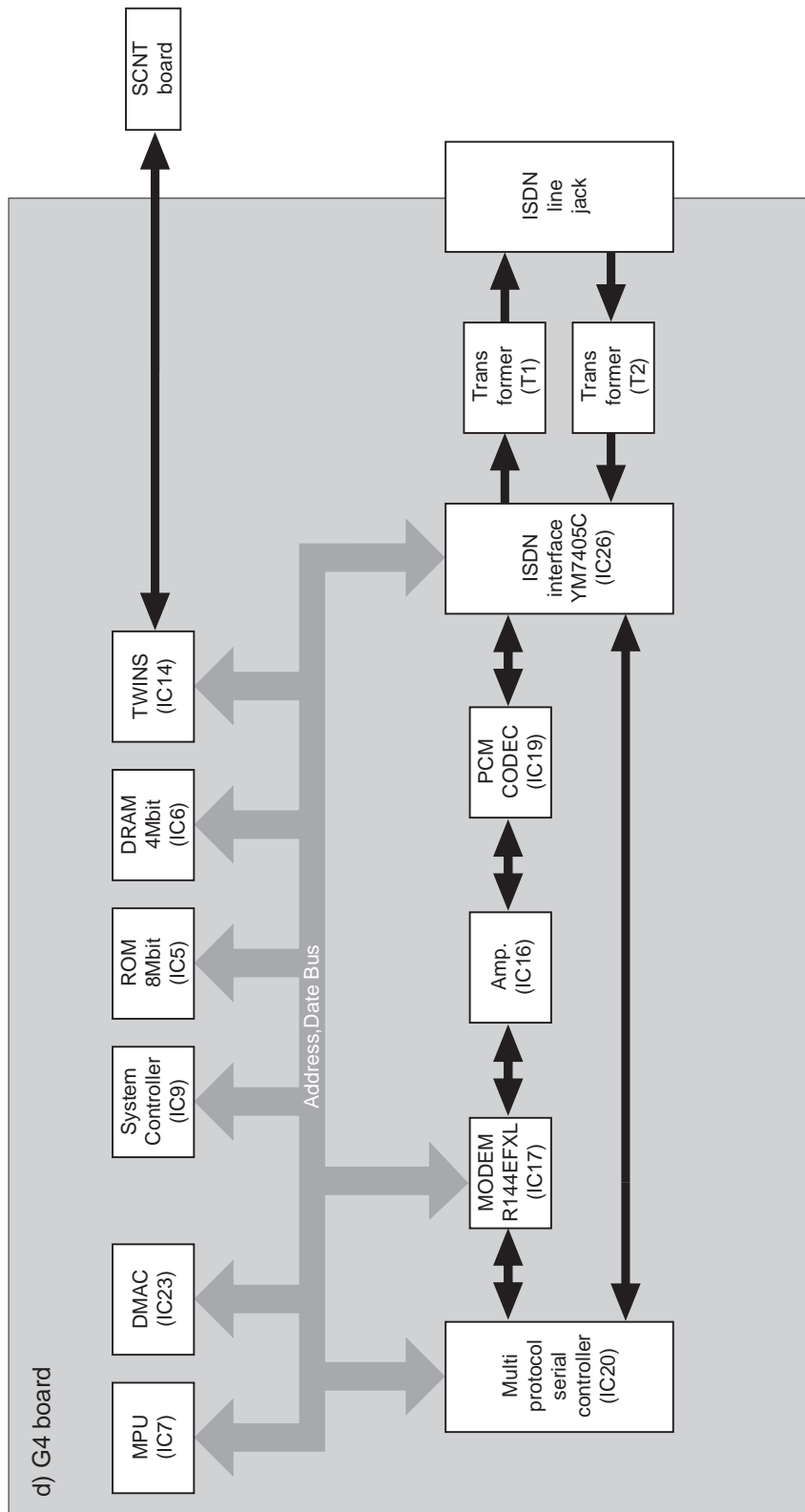

Figure 2-8 G4 Board Block Diagram

**d-1) Modem IC (IC17)**

A Rockwell R144EFXL PQFP is used as the MODEM IC. The MODEM IC carries out G3 modulation conforming to ITU-T standards V.27ter, V.29, V.17 and V.33 on transmitted data received from the MPU during transmission. During reception, the MODEM IC carries out G3 modulation on received signals from the telephone line, according to the same standards.

**d-2) ROM (IC5)**

This 8Mbit ROM contains the control programs (e.g. communications section etc.)

**d-3) DRAM (IC6)**

This 4Mbit DRAM is used as a temporary location to house image data when decoding/encoding image data and performing resolution exchange when data is being transmitted.

**d-4) MPU (IC7)**

The main function of the NEC UPD70741GC-25-7EA are as follows:

- 32 bit CPU
- 24 bit address bus
- 16 bit data bus
- DMA control
- A/D converter
- Software CODEC
- Interrupt control unit

**d-5) PCM CODEC IC (IC19)**

This IC converts the analog signal sent from a G3 modem into a digital signal when transmitting with G3. Also, when receiving with G3, it converts the received digital signal into an analog signal.

**d-6) Multi-protocol serial controller IC (IC20)**

This IC performs parallel/serial conversion of D-channel (Layer 3) data, and each B-channel data when transmitting with G4, between the DRAM (IC6) and the ISDN interface IC (IC26) interface, and performs parallel/serial conversion of B-channel data when transmitting with G3 between the DRAM (IC6) and the modem (IC7). It also performs ISDN interface IC (IC26) and HDLC (High level Data Link Control procedures) when handling D-channel (Layer 3) data, B-channel data when transmitting with G4, and image data when transmitting with G3 (ECM).

**d-7) DMA controller IC (IC23)**

Performs DMA (Direct Memory Access) control between the DRAM (IC6) and the Multi-protocol serial controller IC (IC20) when transmitting with G4/G3.

**d-8) ISDN interface IC (IC26)**

This YAMAHA-made IC YM7405C has Layer 1 functions, Layer 2 functions (LAPD), and Layer 3 interface functions for connection to an ISDN circuit.

**d-9) Transformer (T1, T2)**

Used to provide insulation between the ISDN circuit and the main unit, as well as to satisfy electric characteristics of the ISDN circuit.

**d-10) System controller IC (IC9)**

This Mitsubishi-made M66364FP is a standard cell for control of the MPU's peripheral devices.

**d-11) TWINS (IC14)**

This NEC-made gate array UPD65802GJ-117-3EN controls the IEEE1284's dual-party parallel transmission port.

**d-12) Operation amplifier (IC16)**

This IC amplifies the image data signal, V.21 signal, etc. when using G3 transmission.



**This page intentionally left blank**

### 5.3 Flow of Image Signals

#### a) Transmission

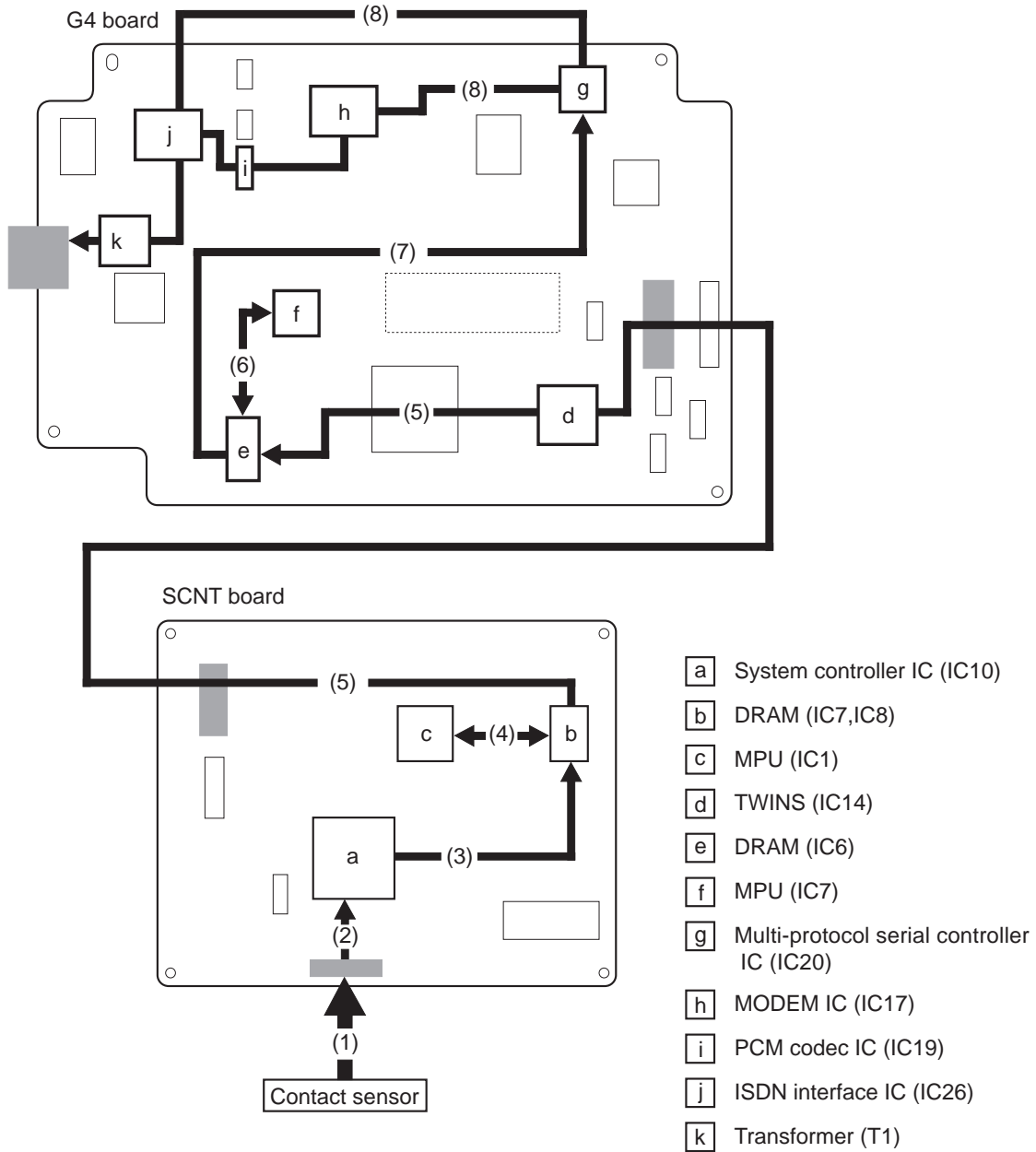

Figure 2-9 Transmission Image Signal Flow

- (1) The document is read by the contact sensor and converted to analog image data. After that, the analog image data is sent to the SCNT board.
- (2) The system controller IC converts analog image data from the contact sensor to digital image data.
- (3) The system controller IC converts processed image data from serial data to parallel data, and writes them to the DRAM.
- (4) The MPU encodes image data in the DRAM using a soft codec, and rewrites the encoded data into the DRAM.
- (5) The encoded image data passes through the centronics interface, is DMA forwarded and written to the G4 board's DRAM.
- (6) The encoded image data is decoded to one-time data with the MPU's soft codec, and converted to a resolution when transmitted. After this new raw image data is encoded with the transmission encoding method, it is read into DRAM again.
- (7) Image data is converted from parallel data to serial data by the multi-protocol serial controller IC, and HDLC framed.
- (8) With G4 transmission, image data passes through the ISDN interface IC, transformer and the ISDN line terminal to the ISDN line. With G3 transmission, image data is modulated by the MODEM IC, and after being converted to digital data by the PCM codec IC, passes through the ISDN interface IC, Transformer, and ISDN terminal to the ISDN line.

b) Reception

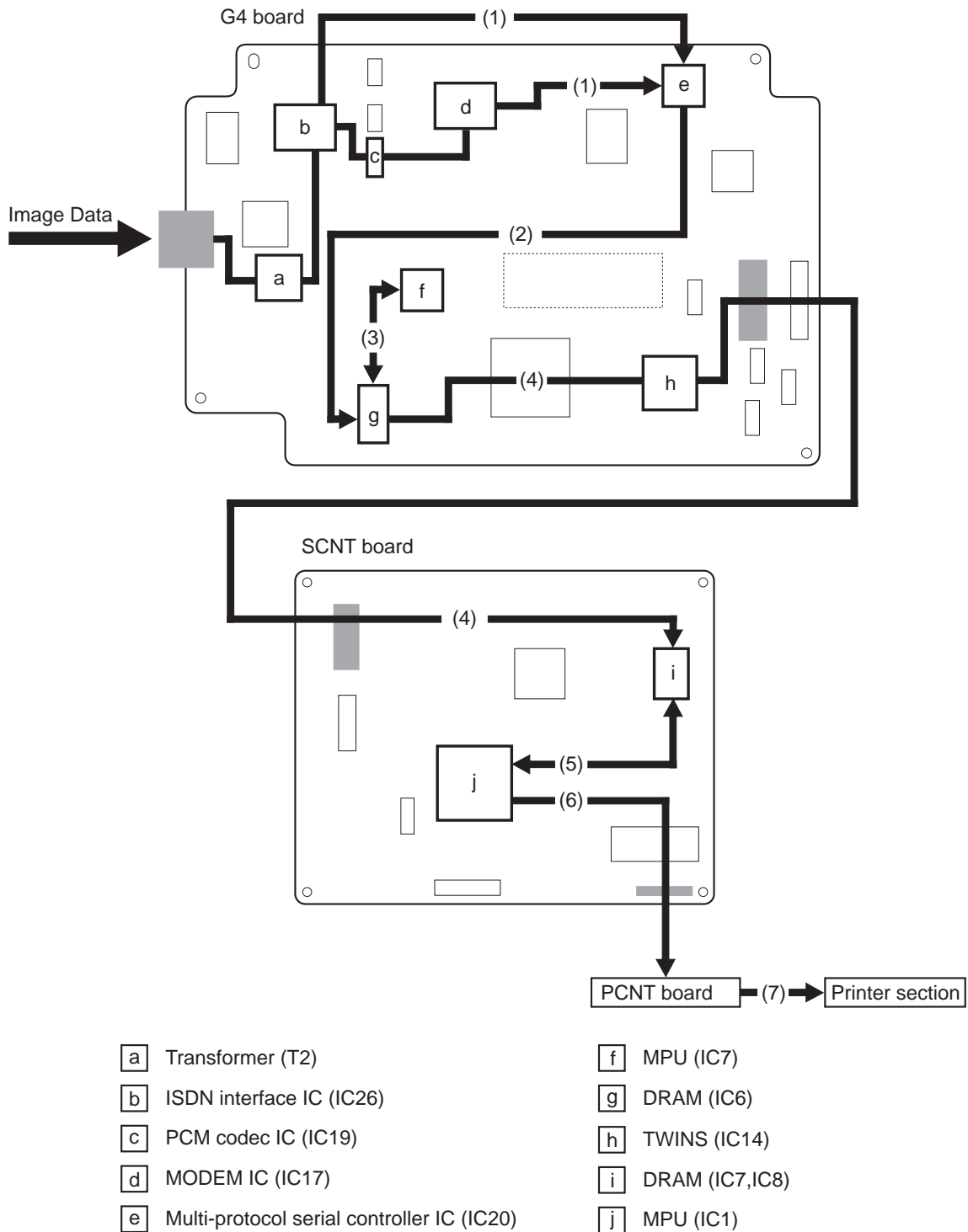

Figure 2-10 Reception Image Signal Flow

- (1) When receiving with G4, the received data is sent through the ISDN terminal, Transformer, and ISDN interface IC to the multi-protocol serial controller IC. When receiving with G3, the received data is converted to analog data by the PCM coded IC, and after being demodulated by the MODEM IC, is sent to the multi-protocol serial controller.
- (2) The image data is converted from serial data to parallel data by the multi-protocol serial controller, and then stored in DRAM.
- (3) After the encoded image data is decoded to one-time raw data by soft codec in the MPU, it is again written to DRAM.
- (4) The encoded image data passed through the centronics interface, is DMA forwarded and written to the SCNT board's DRAM.
- (5) The encoded image data is decoded to raw data by the system controller IC.
- (6) The system controller IC then converts the resolution of the fax data to the appropriate resolution for the printer data, and send it to the printer controller IC on the PCNT board.
- (7) The printer controller IC prints data by controlling the main motor, LASER, and high voltage according to the received print data.

## 6. COMMUNICATION SYSTEM OPERATIONS

### 6.1 ISDN Protocol Messages

Main messages which are used in the communication protocols of Layer 2 - Layer 3 of the control channel's D-channel and Layer 2 - Layer 6 of the information channel's B-channel are listed.

#### 6.1.1 D-channel messages

##### a) Layer 2

Message	Description	Remark
SABME	Set Asynchronous Balanced Mode Extended	The first thing sent when layer 2 is set.
UA	Unnumbered Acknowledge	A reply message for SABME, DISC.
DISC	Disconnect	Sent when layer 2 is released.

##### b) Layer 3

Message	Description	Remark
SETUP	Request for call settings	First sent by the calling party after setting layer 2 when making call settings. For the called party, it does not matter whether or not layer 2 is connected, SETUP will be done anyway. Then, if layer 2 has not been connected on the called party, it will be connected, and following that CONN, etc. will be sent.
SETUP ACK	SETUP Acknowledge	SETUP confirmation (request for additional information)
CALL PROC	Call Proceeding	This means that the calling party SETUP has been received by ISDN. It is an option message.
CONN	Connect	On the calling party, receives when the other terminal has responded. On the called party, sent for accepted SETUP when able to respond.
CONN ACK	Connect Acknowledge	On the calling party, sent for received CONN. On the called party, ISDN sent for the transmitted CONN.
ALERT	Alerting	On the calling party, receives when the other terminal is in a call. On the called party, sent when the user is in a call. It is an option message.
DISC	Disconnect	Sent when layer 3 is disconnected. Receives when disconnected from ISDN.
REL	Release	Sent when layer 3 is released or when DISC is received.
REL COMP	Release Complete	Sent when REL is received. ISDN sends with the transmitted REL.

### 6.1.2 B-channel messages

#### a) Layer 2

Message	Description	Remark
SABM	Set Asynchronous Balanced Mode	The first thing sent when layer 2 is set.
UA	Unnumbered Acknowledge	A reply message for SABM, DISC.
DISC	Disconnect	Sent when layer 2 is released.

#### b) Layer 3

Message	Description	Remark
CR	Call Request	Sent when layer 3 connects.
CN	Incoming Call	Received when layer 3 is connected.
CC	Call Connected	Reply for CR.
CA	Call Accepted	Reply for CN.
SQ	Restart Request	Sent before layer 3 connects.
SI	Restart Indication	Received before layer 3 is connected.
SF	Restart Confirmation	Reply for SQ/SI.
CQ	Clear Request	Sent when layer 3 disconnects.
CI	Clear Indication	Received when layer 3 is disconnected.
CF	Clear Confirmation	Reply for CQ/CI.

#### c) Layer 4

Message	Description	Remark
TCR	Transport Connection Request	Sent when layer 4 connects.
TCA	Transport Connection Accepted	Sent when TCR is received and layer 4 can be connected.
TCC	Transport Connection Clear	Sent when TCR is received and layer 4 cannot be connected.
TBR	Transport Block Reject	Sent when an error is found in layer 4 information.

#### d) Layer 5

Message	Description	Remark
CSS	Command Session Start	The first thing sent when layer 5 is started. Canon mode communication parameters are mainly added to this command.
RSSP	Response Session Start Positive	Sent when CSS is received and layer 5 can be started. Canon mode communication parameters are mainly added to this command.
RSSN	Response Session Start Negative	Sent when CSS is received and layer 5 cannot be started.
CSE	Command Session End	Sent when layer 5 is completed.
RSEP	Response Session End Positive	Reply for CSE.
CSCC	Command Session Change Control	Sent when it becomes layer 5's turn to transmit. This is used by polling communications, etc.

**d) Layer 5 (Continue)**

Message	Description	Remark
RSCCP	Response Session Change Control Positive	Reply for CSCC
CSUI	Command Session User Information	Indicates that there is a document procedure command.
RSUI	Response Session User Information	Indicates that there is a document procedure response.
CSA	Command Session Abort	Sent when the session procedure is halted.
RSAP	Response Session Abort Positive	Reply for CSA.
CDS	Command Document Start	Sent when the document procedure is started. States the size and resolution of pages that are able to be transmitted to CDE.
CDE	Command Document End	Sent when the document procedure is completed.
RDEP	Response Document End Positive	Reply for CDE.
CDPB	Command Document Page Boundary	Sent when it is shown that there is a gap between pages. A check point reference number is added as a parameter.
RDPBP	Response Document Page Boundary Positive	Sent when a page designated as CDPB is OK. A check point reference number is added as a parameter.
RDPBN	Response Document Page Boundary Negative	Sent when a page designated as CDPB is NG. A check point reference number is added as a parameter.
CDCL	Command Document Capability List	Indicates the function of the sending side (page size, resolution).
RDCLP	Response Document Capability List Positive	Indicates the function of the receiving side (page size, resolution).
CDR	Command Document Resynchronize	Sent when the document procedure on the sending side is halted.
RDRP	Response Document Resynchronize Positive	Reply for CDR.
CDD	Command Document Discard	Sent when the document procedure on the sending side is halted.
RDDP	Response Document Discard Positive	Reply for CDD.
RDGR	Response Document General Reject	Sent when a document procedure error is discovered on the receiving side.
CDUI	Command Document User Information	Indicates that there is data from layer 6 and higher (MMR).



**e) Layer 6**

Message	Description
P-START	Added to the front of the image data (page) as that page's attribute (paper, size, resolution) parameter.
P-END	Added to the end of the image data (page) for P-START.
PIX	The image data header, or the image data (MMR).



**NOTE**

---

The message names (P-START, P-END, and PIX) are terms only used within Canon. Please note that recommendations for these message names are not being considered.

---

### 6.2 D-Channel Standard Protocol

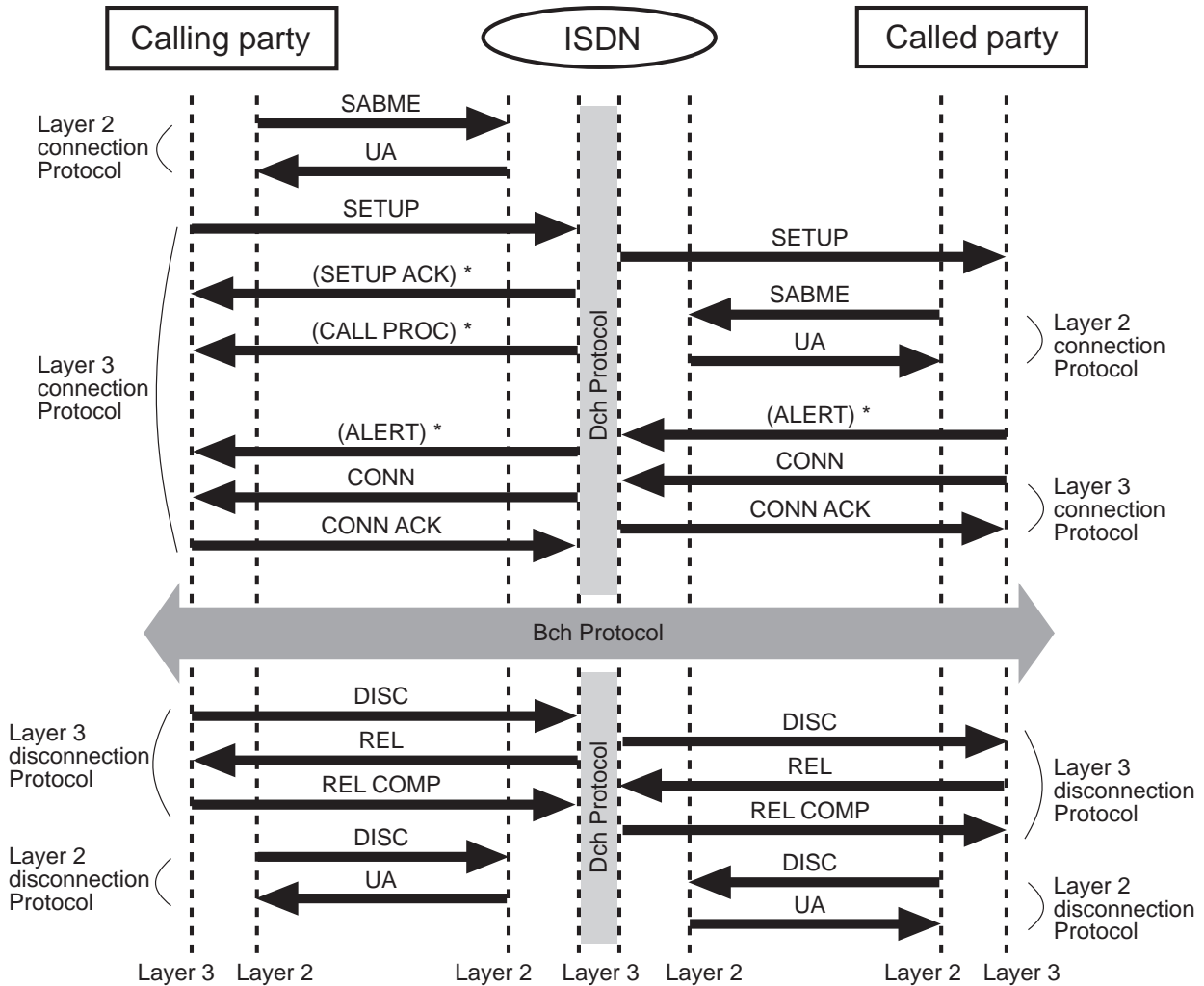

\*: Messages in brackets are options.

Figure 2-11 D-Channel Protocol Flow

### **6.2.1 Information elements in the SETUP message**

The SETUP message is one of the messages used in the D-channel Layer 3 communication protocol, as opposed to a network, and requires commencement of call settings. It is listed here, in the information element included in the main message, as a necessary element for the machine's service.

#### **Sending Complete**

Gives notification of completion of the Called Party Number destination. Addition of this required information is handled as an option in ITU-T recommendations. Additionally, the required information can be set as "Add/Do not Add" with a service switch on this machine.

#### **Bearer Capability**

Sets an outgoing G4 call to "unrestricted digital", an outgoing G3 call to "3.1kHz audio", and telephone to "speech". (There is no telephone in this machine.) It must be ensured that the information in question is added according to ITU-T recommendations.

#### **Channel Identification**

Designates the B-channel which will be used from now on. "B1 channel", "B2 channel", "any channel", and "no channel" will all be set. It must be ensured that the information in question is added according to ITU-T recommendations.

#### **Progress Indicator**

Notifies the channel generated for the call. Addition of this required information is handled as an option in ITU-T recommendations. Additionally, using a service switch, the progress contents can be set, and the required Progress Indicator information can be set as "Add/Do not Add" on this machine.

#### **Calling Party Number**

Sets the phone number of the calling party (=the machine itself). Addition of this required information is handled as an option in ITU-T recommendations.

#### **Called Party Number**

Sets the telephone number of the called party. Addition of this required information is handled as an option in ITU-T recommendations.

#### **Low Layer Compatibility**

Sets an outgoing G4 call to "unrestricted digital", an outgoing G3 call to "3.1kHz audio", and telephone to "speech". (There is no telephone in this machine.) Addition of this required information is handled as an option in ITU-T recommendations. Additionally, this machine can use a service switch to set the required information to "Add/Do not Add" in the SETUP message when calling with G4/G3.

#### **High Layer Compatibility**

With an outgoing G4 call, "G4 FAX" is set, with an outgoing G3 call, "G2/G3 FAX", and with telephone, "TEL". (There is no telephone in this machine.) Addition of this required information is handled as an option in ITU-T recommendations. Additionally, this machine can use a service switch to set the required information to "Add/Do not Add" in the SETUP message when making an outgoing G4/G3 call.

### 6.3 B-Channel Standard Protocol

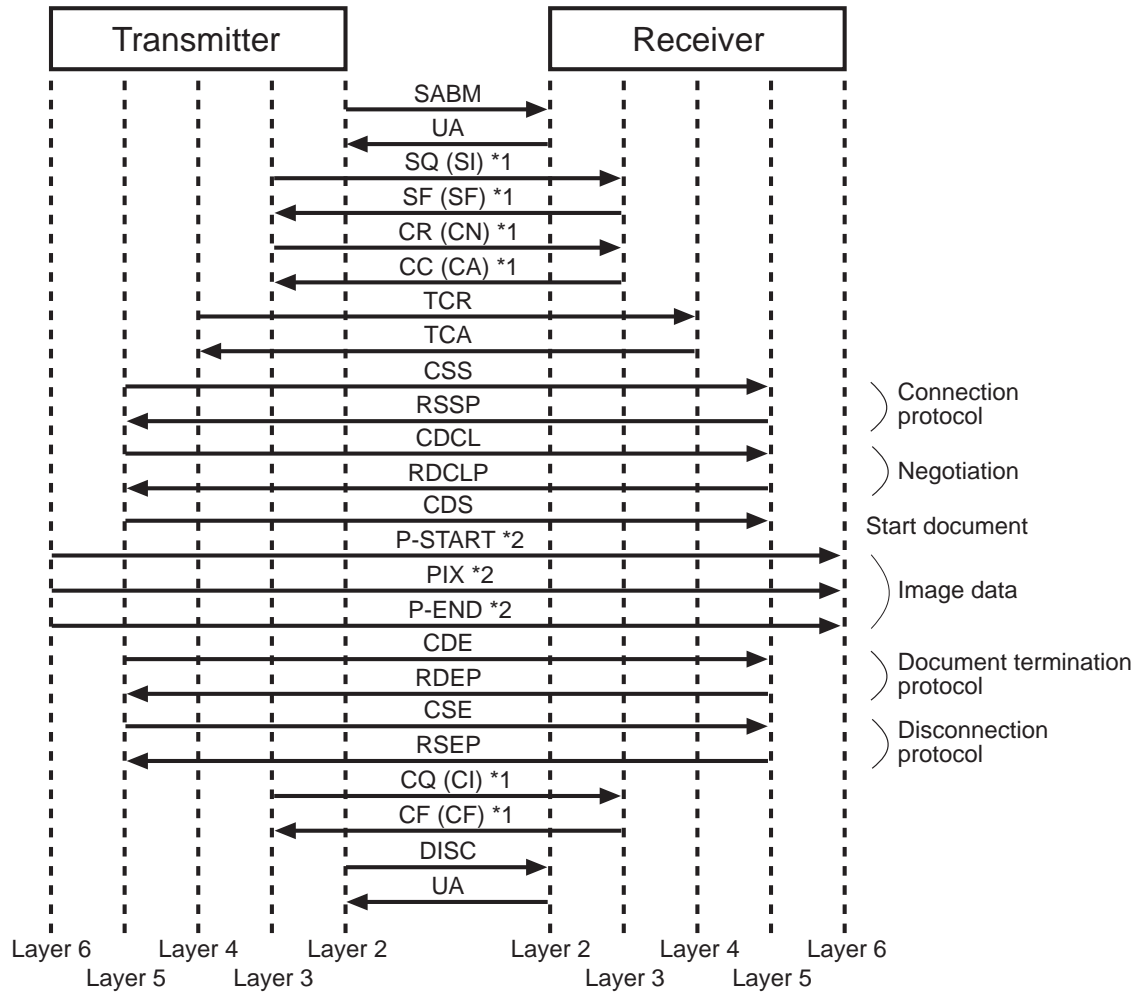

\*1: The message seen by the receiving side is in brackets.

\*2: The messages are terms only used within Canon.

Please note that recommendations for these message names are not being considered.

Figure 2-12 B-Channel Protocol Flow

## **7. NEW FUNCTION**

There is no new function in this model.

**This page intentionally left blank**

# ***Chapter 3***

## ***Maintenance & Service***





# 1. MAINTENANCE LIST

## 1.1 Consumables

Level	Consumable	When
User	Toner cartridge (FX3)	When “ <b>CHANGE CARTRIDGE</b> ” is displayed.
Service technician	None	

## 1.2 Cleaning

Level	Location	When
User	Main unit outer covers	When dirty.
	Separation roller	When document separation/ feed performance falls.
	Separation guide	When document separation performance falls.
	White sheet	When copied and transmitted images are faint.
	Scanning glass (contact sensor)	When black vertical stripes appear in copied or transmitted images.
Service technician	Paper feed guide	When marks appears on back of paper in copied or received images.
	Paper pickup roller	When recording paper feed performance falls.
	Transfer charging roller	When marks on back of paper or blank spots at intervals of 1.96" (50 mm) appear in copied or received images.
	Static charge eliminator	When polka appear dots in copied or received images.
	High-voltage terminal	When copied or received images are light, dark, or completely blank.

<b>Level</b>	<b>Location</b>	<b>When</b>
Service technician	Fixing entrance guide	When marks , marks on back of paper, irregular/smudged black vertical line, paper jam, wrinkles in copied or received images.
	Paper face-up eject roller	When paper jams occur during copying or receiving.
	Flapper	When paper jams occur frequently during copying or receiving.
	Document feed roller	When document feed performance falls.
	Document eject roller	When document feed performance falls.
	Pressure roller	When marks appear on back of paper at intervals of 2.48" (63 mm), or poor fixing, paper jam, or wrinkles occur during copying or receiving.
	Fixing ass'y	When marks appear at intervals of 2.95" (75 mm) or poor fixing of copied or received images occurs.
	Separation pad	When recording paper separation performance falls.

### **1.3 Periodic Inspection**

None

### **1.4 Periodic Replacement Parts**

<b>Level</b>	<b>Location</b>	<b>When</b>
User	None	
Service technician	Separation guide ass'y	When scanned document count exceeds approx. 30,000 pages.

### 1.5 Adjustment Items

None

### 1.6 General Tools

<b>Tool</b>	<b>Use</b>
Phillips screwdriver	Removing/inserting screws
Flat bladed screwdriver	Removing/inserting screws
Precision flat bladed screwdriver	Removing plastic tabs
Tweezers	Removing coil spring
Pliers, needle nose	Driving retaining ring
Lint-free paper	Clean transfer charging roller, fixing film
Isopropyl alcohol	Clean fixing film, fixing entrance guide, fixing pressure roller, fixing eject roller, fixing eject guide, static charge eliminator, etc.

### 1.7 Special Tools

<b>Tool</b>	<b>Use</b>	<b>Part No.</b>
Grease (MOLYKOTE EM-50L)	Apply to specified parts	HY9-0007
Grease (IF-20)	Apply to specified parts	CK-8006
IC-Removing Tool (24P~64P)	Remove the ROM	HY9-0022

## 2. HOW TO CLEAN PARTS

### 2.1 Main Unit Outer Covers

Lightly wipe the unit's outer casing with a clean, soft, lint-free cloth moistened with water or diluted dishwashing detergent solution.

### 2.2 Separation Roller

Wipe with a soft, dry clean cloth.

### 2.3 Separation Guide

Wipe with a dry clean soft cloth.

### 2.4 White Sheet

Wipe with a soft, dry clean soft cloth.

### 2.5 Scanning Glass (Contact Sensor)

Wipe with a soft, dry clean cloth.

### 2.6 Paper Feed Guide

Wipe with a clean, soft, dry, lint-free cloth to remove any toner or paper debris.



---

Do not touch the transfer changing roller during cleaning. Otherwise, the print quality may deteriorate.

---



---

If Separation roller, Separation guide and Paper pickup roller are very dirty, wipe with a cloth moistened with Isopropyl alcohol (IPA). Do not use tissue paper. Dust from the tissue paper causes static electricity.

---

#### **Precautions when using Isopropyl alcohol (IPA)**

When cleaning with IPA, take care to prevent the IPA from splashing high-temperature parts. If IPA splashes high-temperature parts, leave for at least three minutes to allow the IPA to evaporate.

---

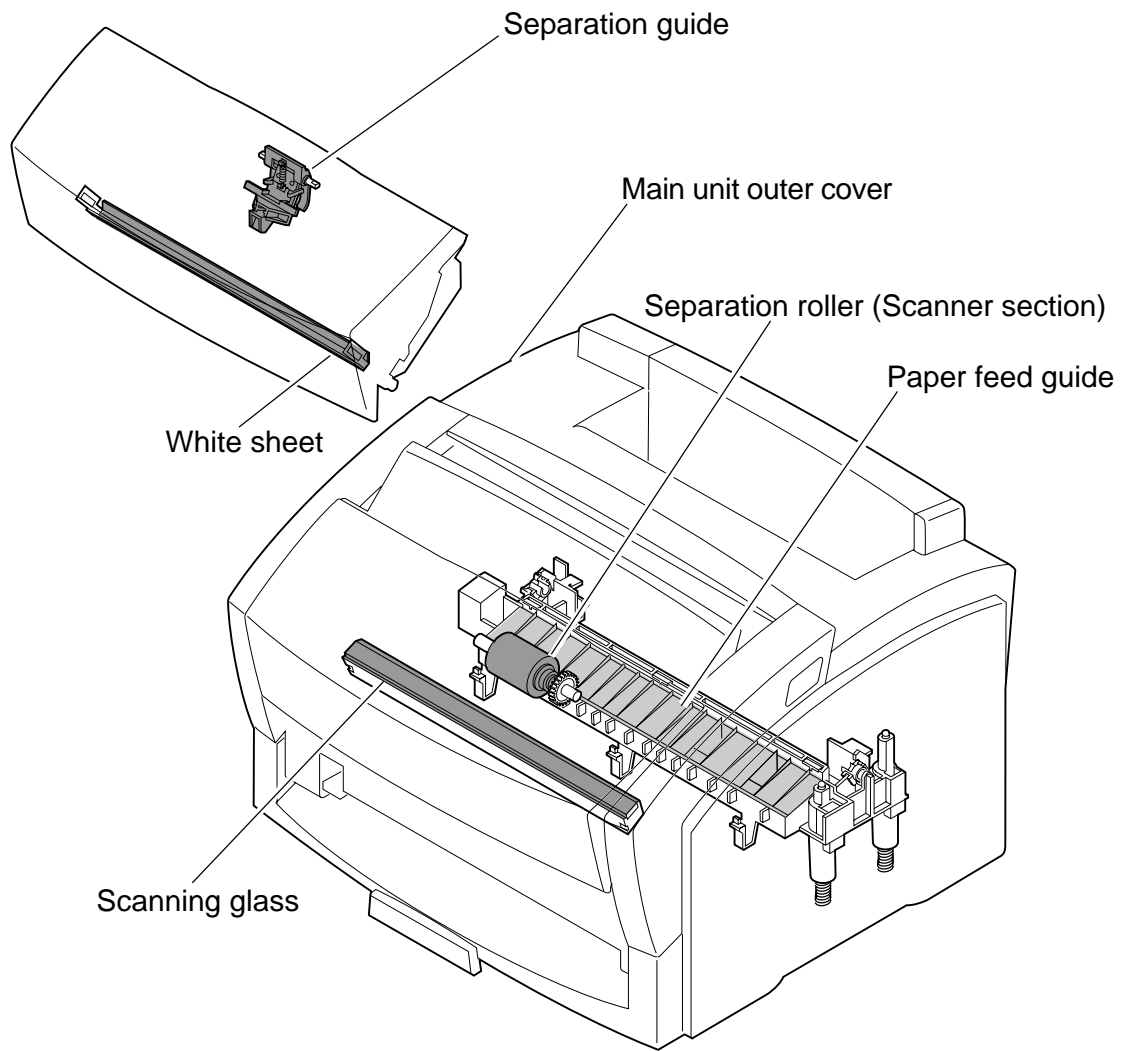

Figure 3-1 Cleaning Location 1

## **2.7 Paper Pickup Roller**

Using lint-free paper dipped in isopropyl alcohol, wipe and dirt off the paper pickup roller.

## **2.8 Transfer Charging Roller**

Wipe with lint-free paper and remove any toner or paper debris.



---

Do not touch or hold the sponge section of the transfer charging roller. Doing so can cause marks on back of paper or blank spots in copied or received images.

### **Never clean with solvents**

Replace the charging roller if it is deformed or cannot be thoroughly cleared using lint-free paper.

---

## **2.9 Static Charge Eliminator**

Wipe with a lint-free paper and remove any foreign matter, such as paper fragments.

## **2.10 High Voltage Terminal**

Wipe with a clean, soft, dry, lint-free cloth to remove any toner or paper debris.

## **2.11 Fixing Entrance Guide**

Wipe with a lint-free paper and remove any toner or paper debris.

## **2.12 Paper Face-up Eject Roller**

Using lint-free paper dipped in isopropyl alcohol, wipe off the paper eject face-up roller.

## **2.13 Flapper**

Wipe with a lint-free paper and remove any toner or paper debris.

## **2.14 Document Feed Roller, Document Eject Roller**

Wipe with a soft, dry clean cloth.

## **2.15 Pressure Roller**

Using lint-free paper dipped in isopropyl alcohol, wipe off the pressure roller.

## **2.16 Fixing Ass'y**

Using lint-free paper dipped in isopropyl alcohol, wipe off the fixing ass'y.

## **2.17 Separation Pad**

Using cloth dipped in isopropyl alcohol, wipe off the separation pad.

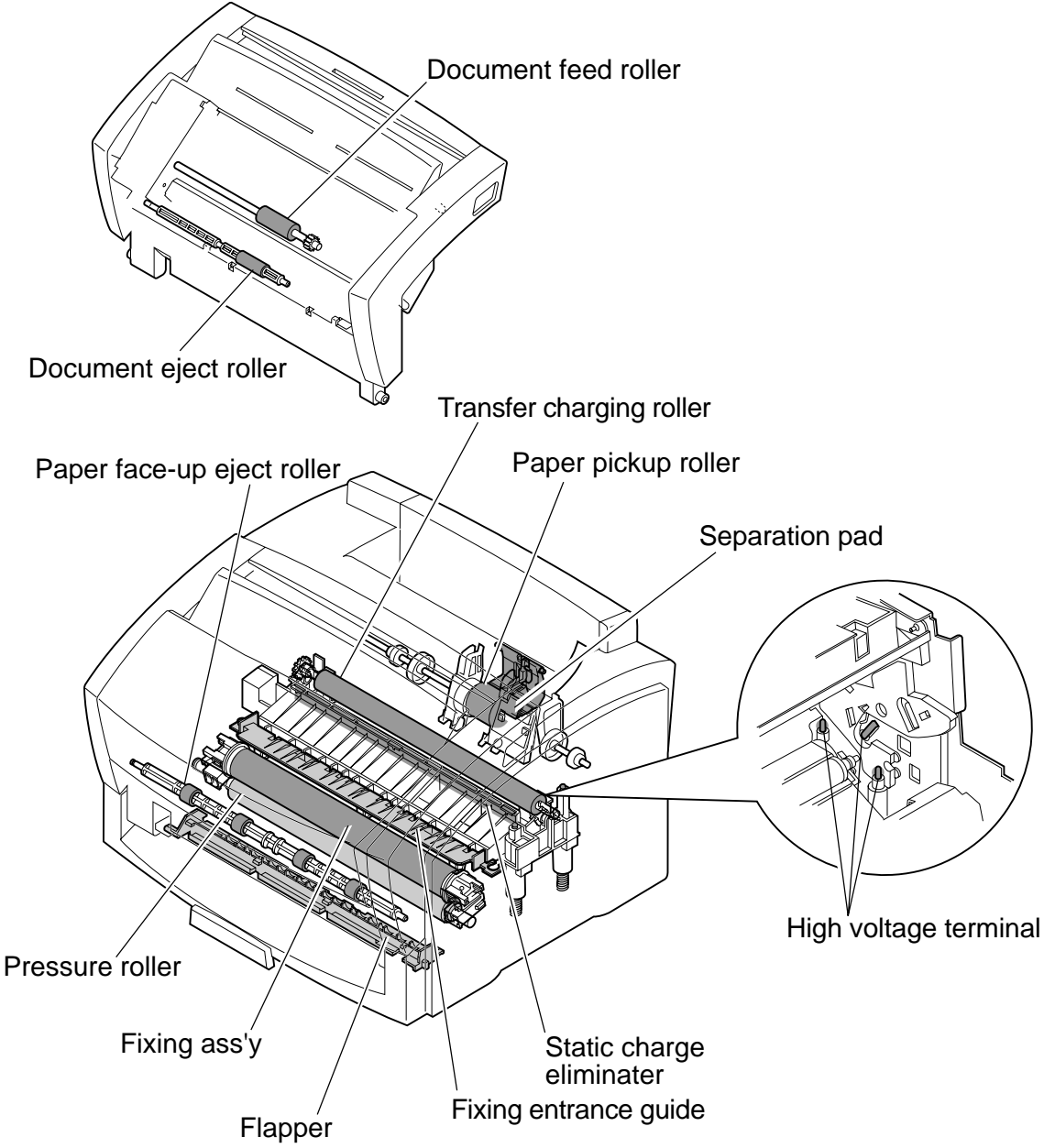

Figure 3-2 Cleaning Location 2

## **3. REPLACING PARTS & ADJUSTMENTS**

### **3.1 Replacing parts**

For details on the disassembly/assembly procedure when replacing parts, refer to the Parts Catalog (separate). Illustrations in the Parts Catalog are drawn in the order in which parts are disassembled. The Parts Catalog also shows enlarged drawings or supplementary illustrations for parts requiring caution during disassembly and assembly. Particular care should be paid to the cautions contained in illustrations.

### **3.2 Adjustment**

None



## 4. TROUBLESHOOTING

### 4.1 Troubleshooting Index

Use the troubleshooting index below to investigate the cause of a problem and refer to the specified page for countermeasures.

#### Problem

##### • General errors

- The unit does not power on. Page 3-44
- The display looks abnormal. Page 3-44
- The buttons do not work. Page 3-44
- No sound from the speaker Page 3-44

##### • Errors shown on the display

- User error message. Page 3-10
- Error codes. Page 3-13
  - D-channel error codes Page 3-19
  - B-channel error codes Page 3-39

##### • Printing problems (Evaluation criteria: Test printing is faulty.)

- The paper is not fed correctly. Page 3-45
  - The main motor does not run.
  - The paper is not picked up from the auto sheet feeder.
  - The paper skews.
- The printing operation is abnormal. Page 3-45
  - The unit indicates a paper jam when there is none.
- Poor printing quality Page 3-46
  - Light
  - Dark
  - Completely blank
  - All black
  - Dots
  - Marks on back of papers
  - Black vertical lines
  - Irregular and smudged black vertical lines
  - Irregular and smudged black horizontal lines
  - Marks
  - Blank spots
  - White vertical lines
  - White horizontal lines
  - Faulty registration
  - Distortion/BD signal failure
  - Partially compressed/stretched image
  - Poor fixing

• **Scanning problems (Evaluation criteria: Test printing is good, but the copied image is poor.)**

- The document is not fed. **Page 3-51**

- The document feed motor does not run.
  - The document slips against the rollers.
  - The document does not separate.
  - The scanner unit's sensors are defective

- The scanning image is abnormal. **Page 3-52**

- Nothing is printed.
  - The image has vertical stripes.
  - The image has thick vertical stripes.

- **Communication problems** **Page 3-52**

- D-channel connection error
- Cannot perform G4 communication.
- Cannot receive.

## 4.2 Errors Shown on the Display

### 4.2.1 User error message

Look for the applicable error message and implement the appropriate countermeasures.

#### "BUSY/NO SIGNAL" (#005/#018)

---

- |                  |   |
|------------------|---|
| <b>Cause:</b>    | The receiving fax did not answer within 55 seconds. (T0 time over)                                |
| <b>Solution:</b> | Contact the other party and have them check their fax. You can try to send the document manually. |
| <b>Cause:</b>    | The other party is not using a G4/G3 machine.   |
| <b>Solution:</b> | Contact the other party and have them send or receive the document using a G4/G3 machine.         |
| <b>Cause:</b>    | The other party's fax is not working.   |
| <b>Solution:</b> | Contact the other party and have them check their fax.  |
| <b>Cause:</b>    | The telephone number you dialed is busy.  |
| <b>Solution:</b> | Try sending the document at a later time.   |

#### "CHECK DOCUMENT" (#001)

---

- |                  |   |
|------------------|---|
| <b>Cause:</b>    | Document jam. This is displayed when the document sensor detects paper, but the document edge sensor cannot detect the leading edge of the document with 15 seconds from the start of the feed operation. |
| <b>Solution:</b> | Clear the document jam.   |

#### "CHECK PAPER SIZE"

---

- |                  |  |
|------------------|--|
| <b>Cause:</b>    | The size of the paper loaded in the paper tray is different from the paper size set by the user data menu. |
| <b>Solution:</b> | Set the correct paper size in the user data setting.   |

#### "CHECK PRINTER" (##322~##324, #335)

---

Check the displayed error code and see the measure to eliminate the error. (See Page 3-17.)

**"CHECK SUB/PWD" (#083, #102)**

---

**Cause:** Subaddress or password does not coincide.  
**Solution:** Contact the other party and match the subaddress/password.

**"DATA ERROR"**

---

**Cause:** The registration data in the SRAM was destroyed and a checksum error occurred due to a dead lithium battery or SRAM failure.  
**Solution:** (1) Press the *START/COPY* button, and turn the power off and on again.  
(2) Replace the lithium battery.  
(3) Replace the SCNT board.

**"DOC. TOO LONG" (#003)**

---

**Cause:** The document is longer than 1 metre.  
**Solution:** Use a copy machine to make a reduced copy of the document, then send again.  
**Cause:** It took more than 32 minutes to send, copy, a document or receive a document.  
**Solution:** Divide the document and send or copy each part separately. Contact the other party and have them divide the document and send each part separately.

**"MEMORY FULL" (#037)**

---

**Cause:** The fax's memory is full because it has received too many documents.  
**Solution:** (1) Print out any documents which are stored in memory. Then start the operation again.  
(2) If the memory contains any facsimiles you don't need, delete them.  
**Cause:** The fax's memory is full because you tried to send too many pages at once.  
**Solution:** Divide the document and send each part separately.

**"NO ANSWER" (#005)**

---

**Cause:** The receiving fax machine does not answer.  
**Solution:** Make sure you dialed the correct number. Try again later.

**"NO PWD POLLING" (#084)**

---

**Cause:** When selective polling, the other party's machine does not have a password reception function.  
**Solution:** Redo selective polling without designating a password.

**"NO PWD TX" (#081)**

---

**Cause:** The other party's machine does not have a password reception function.  
**Solution:** Retransmit without designating a password.

**"NO RX PAPER" (#012)**

---

**Cause:** The receiving fax machine declares no paper in DIS, or its memory is full.  
**Solution:** Contact the other party, and ask them to put paper in their machine, or to clear their fax machine's memory.

**"NO SLCT POLLING" (#082)**

---

**Cause:** The other party's machine does not have a select polling transmission function.  
**Solution:** Redo polling without designating a subaddress.

**"NO SUB TX" (#080)**

---

**Cause:** The other party's machine does not have a subaddress reception function.  
**Solution:** Retransmit without designating a subaddress.

**"NO TEL #" (#022)**

---

**Cause:** The button you pressed has no number registered for One-Touch Speed Dialing, Coded Speed Dialing, or Group Dialing.  
**Solution:** Print a list of registered numbers and make any corrections needed, then try again.

**"NOT AVAILABLE"**

---

**Cause:** One-touch or coded speed dial already registered.  
**Solution:** Check the contents of the one-touch or coded speed dialing registration, then try again.  
**Cause:** The RX CALL FWD setting is incorrect.  
**Solution:** Confirm that the ISDN number is set properly.

**"CLEAR PAPER JAM" (#009)**

---

**Cause:** Paper jam.  
**Solution:** Clear the paper jam.

**"CHANGE CARTRIDGE"**

---

**Cause:** The toner cartridge has run out of toner.  
**Solution:** Replace the toner cartridge.

**"START AGAIN"**

---

**Cause:** An error occurred on the phone line or in the system.  
**Solution:** Start the procedure again from the beginning.

**"LOAD PAPER" (#009)**

---

**Cause:** The fax is out of paper.  
**Solution:** Add more paper to the sheet feeder.

**"CHECK COVER/CART"**

---

**Cause:** The toner cartridge is not installed properly.  
**Solution:** Make sure the toner cartridge is installed properly.  
**Cause:** Front cover is not closed.  
**Solution:** Close front cover.

**"POLLING ID ERROR" (#021)**

---

**Cause:** The polling ID does not coincide with the other party's machine.  
**Solution:** Have the other party set the polling ID to "11111111" or "255."

## 4.2.2 Error codes

### a) Service error code output

When service data #1 SSSW SW01 bit 0 is set to “1”, then service error codes are printed on the activity management reports, reception result reports and error transmission reports when communication is terminated due to an error. Also, the following is displayed when an error occurs.

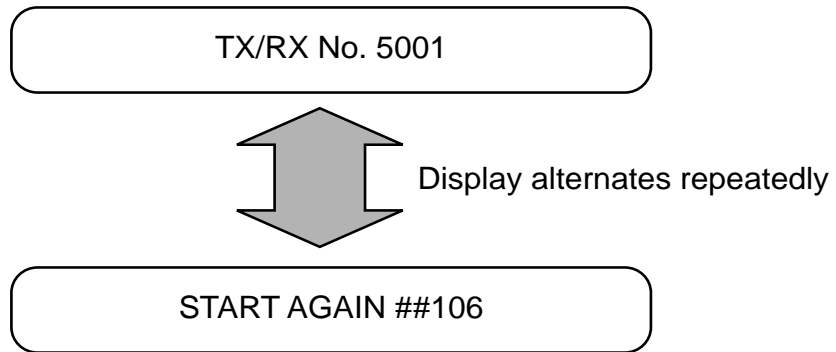

**Figure 3-3 Service Error Code Display**

### b) Error code countermeasures

The following item c) lists all the error codes which the unit can display. The separate *G3 Facsimile Error Code List (Rev. 1)* does not specify the countermeasures for resolvable error codes. Also refer to this list when an error code appears.

Methods for countermeasures regarding D-channel error codes and B-channel error codes are mentioned in item e).

c) ERROR CODE LIST for FAX-L260i

New error codes indicate “new” in this list.

• User error code

No.	Tx or Rx	Definition
#001	[ TX ]	Paper Jam
#003	[ TX/RX ]	Copy Page, Communication Time Over
#005	[ TX/RX ]	Initial ID (T1) Time Over
#009	[ RX ]	Recording Paper Jam or Out of Paper
#011	[ RX ]	Polling Error
#012	[ TX ]	Other party Out of Paper
#018	[ TX/RX ]	Automatic Dialing Error
#021	[ RX ]	DCN during Polling Rx
#022	[ TX ]	Call Failure
#037	[ RX ]	Image Memory Full
#080	[TX ]	Other Party does not have ITU-T Recommended Subaddress Reception Function
#081	[TX ]	Other Party does not have ITU-T Recommended Password Reception Function
#082	[RX ]	Other Party does not have ITU-T Selective Polling Reception Function
#083	[RX ]	Subaddress/Password disagreement when using ITU-T recommended Selective Polling Reception
#084	[RX ]	Other Party does not have ITU-T Recommended Password Reception Function (When using Selective Polling Reception)
#102	[TX/RX ]	Different Password during Password Transmission
#995	[TX/RX ]	Memory Communication reservation cancellation

• Service error code

D-channel error codes and B-channel error codes are not mentioned here. Please refer to item e).

No.	Tx or Rx	Definition
##100	[ TX ]	Excessive Repeat Protocol during Rx
##101	[ TX/RX ]	Modem Speed Different from Other Party
##102	[ TX ]	Fall Back Failure during Tx
##103	[ RX ]	Fail to Detect EOL for 5 Seconds (15 seconds for CBT) during Rx
##104	[ TX ]	RTN or PIN Received during Tx
##106	[ RX ]	Fail to Receive Protocol for 6 Seconds when Waiting for Protocol during Rx
##107	[ RX ]	Fall Back Failure on Tx Side during Rx
##109	[ TX ]	Receive Signals Other than DIS, DTC, FTT, CFR or CRP after DCS Tx and Exceed the Number of Protocol re-transmissions during Tx
##111	[ TX/RX ]	Memory error
##114	[ RX ]	RTN Transmission during Reception
##200	[ RX ]	Fail to Detect Picture Rx Carrier for 5 Seconds during Rx
##201	[ TX/RX ]	DCN received Other than Normal Binary Protocol
##204	[ TX ]	Receive DTC without Tx Data
##220	[ TX/RX ]	System Error (main program runaway)
##223	[ TX ]	Line Disconnect during Communication
##224	[ TX/RX ]	Abnormal Protocol during G3 Communication
##226	[ TX/RX ]	Stack Pointer Not within RAM Range

No.	Tx or Rx	Definition
##229	[ RX ]	Recording Unit Locked for 1 Minute
##232	[ TX ]	ENCODE Control Unit Malfunction
##237	[ RX ]	DECODE Control Unit Malfunction
##238	[ RX ]	PRINT Control Unit Malfunction
##261	[ TX/RX ]	System Error between Modem and SCNT
##280	[ TX ]	Excessive Repeat Protocol Command during Tx
##281	[ TX ]	Excessive Repeat Protocol Command during Tx
##282	[ TX ]	Excessive Repeat Protocol during Tx
##283	[ TX ]	Excessive Repeat Protocol during Tx
##284	[ TX ]	DCN Reception after TCF Transmission
##285	[ TX ]	DCN Reception after EOP Transmission
##286	[ TX ]	DCN Reception after EOM Transmission
##287	[ TX ]	DCN Reception after MPS Transmission
##288	[ TX ]	Receive Signals Other than PIN, PIP, MCF, RTP or RTN after EOP Transmission
##289	[ TX ]	Receive Signals Other than PIN, PIP, MCF, RTP or RTN after EOM Transmission
##290	[ TX ]	Receive Signals Other than PIN, PIP, MCF, RTP or RTN after MPS Transmission
##309	[ TX/RX ]	Abnormality in the communication between the SCNT board and the G4 board
##322	[ RX ]	Printer (LBP) Fixing Unit Trouble
##323	[ RX ]	Printer (LBP) BD (Beam Detect) Trouble
##324	[ RX ]	Printer (LBP) Scanner Trouble
##335	[ TX/RX ]	Data communication error between system control section and Printer control section
##750	[ TX ]	Exceed Repeat Protocol Due to Failure to Receive Significant Signals after Transmitting PPS-NULL during ECM Tx
##752	[ TX ]	Receive DCN after PPS-NULL Transmission during ECM Tx
##753	[ TX ]	Exceed Protocol Retransmission Limit or T5 Time (60 seconds) after PPS-NULL Transmission during ECM Tx
##754	[ TX ]	Exceed Retransmit Protocol after PPS-NULL Transmission during ECM Tx
##755	[ TX ]	Exceed Protocol Retransmission Limit Due to Failure to Receive Significant Signals after PPS-MPS Transmission during ECM Tx
##757	[ TX ]	Receive DCN after PPS-MPS Transmission during ECM Tx
##758	[ TX ]	Exceed Protocol Retransmission Limit or T5 Time (60 seconds) after PPS-MPS Transmission during ECM Tx
##759	[ TX ]	Exceed Retransmit Protocol after PPS-MPS Transmission during ECM Tx
##760	[ TX ]	Exceed Protocol Retransmission Limit Due to Failure to Receive Significant Signals after PPS-EOM Transmission during ECM Tx
##762	[ TX ]	Receive DCN after PPS-EOM Transmission during ECM Tx
##763	[ TX ]	Exceed Protocol Retransmission Limit or T5 Time (60 seconds) after PPS-MPS Transmission during ECM Tx
##764	[ TX ]	Exceed Retransmit Protocol after PPS-EOP Transmission during ECM Tx

<b>No.</b>	<b>Tx or Rx</b>	<b>Definition</b>
##765	[ TX ]	Exceed Protocol Retransmission Limit Due to Failure to Receive Significant Signals after PPS-EOP Transmission during ECM Tx
##767	[ TX ]	Receive DCN after PPS-EOP Transmission during ECM Tx
##768	[ TX ]	Exceed Protocol Retransmission Limit or T5 Time (60 seconds) after PPS-EOP Transmission during ECM Tx
##769	[ TX ]	Exceed Retransmit Protocol after PPS-EOP Transmission during ECM Tx
##770	[ TX ]	Exceed Repeat Protocol Limit Due to Failure to Receive Significant Signals after Transmitting EOR-NULL during ECM Tx
##772	[ TX ]	Receive DCN after EOR-NULL Transmission during ECM Tx
##773	[ TX ]	Exceed Protocol Retransmission Limit or T5 Time (60 seconds) after EOR-NULL Transmission during ECM Tx
##774	[ TX ]	Receive ERR after EOR-NULL Transmission during ECM Tx
##775	[ TX ]	Exceed Protocol Retransmission Limit Due to Failure to Receive Significant Signals after EOR-MPS Transmission during ECM Tx
##777	[ TX ]	Receive DCN after EOR-MPS Transmission during ECM Tx
##778	[ TX ]	Exceed Protocol Retransmission Limit or T5 Time (60 seconds) after EOR-MPS Transmission during ECM Tx
##779	[ TX ]	Receive ERR after EOR-MPS Transmission during ECM Tx
##780	[ TX ]	Exceed Protocol Retransmission Limit Due to Failure to Receive Significant Signals after EOR-EOM Transmission during ECM Tx
##782	[ TX ]	Receive DCN after EOR-EOM Transmission during ECM Tx
##783	[ TX ]	Exceed Protocol Retransmission Limit or T5 Time (60 seconds) after EOR-EOM Transmission during ECM Tx
##784	[ TX ]	Receive ERR after EOR-EOM Transmission during ECM Tx
##785	[ TX ]	Exceed Protocol Retransmission Limit Due to Failure to Receive Significant Signals after EOR-EOP Transmission during ECM Tx
##787	[ TX ]	Receive DCN after EOR-EOP Transmission during ECM Tx
##788	[ TX ]	Exceed Protocol Retransmission Limit or T5 Time (60 seconds) after EOR-EOP Transmission during ECM Tx
##789	[ TX ]	Receive ERR after EOR-EOP Transmission during ECM Tx
##790	[ RX ]	Transmit ERR after EOR-Q Reception during ECM Rx
##791	[ TX/RX ]	Receive Non-Significant Signals during ECM Mode Procedures
##792	[ RX ]	Fail to Detect PPS-NULL between Partial Pages during ECM Rx
##793	[ RX ]	Time Over Due to Failure to Receive Valid Frame during High Speed Signal Rx upon ECM Rx
##794	[ TX ]	Receive All 0 PPR during ECM Tx
##795	[ TX/RX ]	Trouble in the decoding processing during communication
##799	[ TX ]	System Error



**d) New error codes and recovery methods**

There is no new error code in this model.

Note, however, the following supplementary information, as the machine requires different actions than the existing models to correct:

**##322 [TX/RX] Fixing heater temperature abnormality**

---

**Cause:** Internal unit defect.

- Solutions:**
- (1) Check the connections between the fixing ass'y and the PCNT board (J203) and between the fixing ass'y and the power supply unit (J102).
  - (2) Check the connection between the PCNT board (J403) and the power supply unit (J202).
  - (3) Check the resistance between connector pins of the fixing ass'y.  
J203-12 and J203-13: 436 to 301 k (at 25°C)  
J102-1 and J102-2: 25.1 to 28.8 (at 25°C)  
If either resistance is incorrect, replace the fixing ass'y.
  - (4) Replace the PCNT board.
  - (5) Replace the power supply unit.
  - (6) Replace the SCNT board.

**##323 [TX/RX] LASER/scanner section BD signal output abnormal**

---

**Cause:** Internal unit defect (Low LASER intensity)

- Solutions:**
- (1) Check the connection between the LASER/scanner section (J801) and the PCNT board (J203).
  - (2) Replace the LASER/scanner section.
  - (3) Replace the PCNT board.
  - (4) Replace the SCNT board.

**Cause:** Internal unit defect (BD signal timing error)

- Solutions:**
- (1) Check the connection between the LASER/scanner section (J801) and the PCNT board (J203).
  - (2) Replace the LASER/scanner section.
  - (3) Replace the PCNT board.
  - (4) Replace the SCNT board.

**##324 [TX/RX] Printer section scanner motor rotation rate abnormal**

---

**Cause:** Internal unit defect (Incorrect scanner motor speed)

- Solutions:**
- (1) Check the connection between the LASER/scanner section (J1) and the PCNT board (J203).
  - (2) Replace the LASER/scanner section.
  - (3) Replace the PCNT board.
  - (4) Replace the SCNT board.

**##335 [TX/RX] Data communication error between system control section and printer control section**

---

- Cause:** Internal unit defect
- Solutions:**
- (1) Check the connections between the PCNT board (J201) and the SCNT board (J8) and between the PCNT board (J403) and power supply unit (J202).
  - (2) Replace the PCNT board.
  - (3) Replace the SCNT board.
  - (4) Replace the power supply unit.

**##309 [TX/RX]**

---

- Cause:**
- The board's interface message cycle has become disorganized.
  - A problem has arisen with the board's interface P1284.
  - There is an abnormality with the board, it cannot operate.
- Solutions:**
- (1) Switch the power OFF/ON.
  - (2) Replace the SCNT Board-G4 Board cable.
  - (3) Replace the G4 Board.
  - (4) Replace the SCNT Board.

**e) D-channel error codes and B-channel error codes**

• **D-channel error codes (##1001-##1131)**

D-channel protocol error codes are generated by taking the “cause number” notified which has been notified by the network and adding “1000” to it inside the machine. The required reason for the disconnection or restoration is assigned in the “cause number”, but even if the “cause number” notified by the each country’s network is identical, there will be times when the required reason for the disconnection or restoration will differ.

**##1001 [TX/RX] a) Unallocated (unassigned) number**

**b) Invalid call reference value**

**Cause a):** Indicated above

- Solutions a):**
- (1) Re-check the phone number and try the call again.
  - (2) Output a communications analysis list, and analyze it.
  - (3) Make sure the 4 digits of the applicable error code are registered in *#4B ISDN BASIC G4/G3 Fallback* and *Speech Fallback* on page 3-74.
  - (4) Take countermeasures as outlined in *D-channel connection error* in *Communication problems* on page 3-52, Section 4.3.4.
  - (5) Make an inquiry to the maker of the Switching equipment.

**Cause b):** Indicated above

- Solutions b):**
- (1) Re-transmit.
  - (2) Output a communications analysis list, and analyze it.
  - (3) Make sure the 4 digits of the applicable error code are registered in *#4B ISDN BASIC G4/G3 Fallback* and *Speech Fallback* on page 3-74.
  - (4) Take countermeasures as outlined in *D-channel connection error* in *Communication problems* on page 3-52, Section 4.3.4.
  - (5) Make an inquiry to the maker of the Switching equipment.

**##1002 [TX/RX] No route to specified transit network.**

**Cause:** Indicated above

- Solutions:**
- (1) Re-check the method of connection to the designated relay network.
  - (2) Output a communications analysis list, and analyze it.
  - (3) Make sure the 4 digits of the applicable error code are registered in *#4B ISDN BASIC G4/G3 Fallback* and *Speech Fallback* on page 3-74.
  - (4) Take countermeasures as outlined in *D-channel connection error* in *Communication problems* on page 3-52, Section 4.3.4.
  - (5) Make an inquiry to the maker of the Switching equipment.

**##1003 [TX/RX] a) No route to destination.**

**b) Designated bearer service not implemented.**

**Cause a):** Indicated above

- Solutions a):**
- (1) Re-check the phone number and try the call again.
  - (2) Output a communications analysis list, and analyze it.
  - (3) Make sure the 4 digits of the applicable error code are registered in *#4B ISDN BASIC G4/G3 Fallback* and *Speech Fallback* on page 3-74.
  - (4) Take countermeasures as outlined in *D-channel connection error* in *Communication problems* on page 3-52, Section 4.3.4.
  - (5) Make an inquiry to the maker of the Switching equipment.

**Cause b):** Indicated above

- Solutions b):**
- (1) Re-check the designated bearer service.
  - (2) Output a communications analysis list, and analyze it.
  - (3) Make sure the 4 digits of the applicable error code are registered in *#4B ISDN BASIC G4/G3 Fallback* and *Speech Fallback* on page 3-74.
  - (4) Take countermeasures as outlined in *D-channel connection error* in *Communication problems* on page 3-52, Section 4.3.4.
  - (5) Make an inquiry to the maker of the Switching equipment.

---

**##1006 [TX/RX] Channel unacceptable.**

**Cause:** Indicated above

- Solutions:**
- (1) Wait a while and then transmit, because the other terminal is in the middle of a transmission.
  - (2) Output a communications analysis list, and analyze it.
  - (3) Make sure the 4 digits of the applicable error code are registered in *#4B ISDN BASIC G4/G3 Fallback* and *Speech Fallback* on page 3-74.
  - (4) Take countermeasures as outlined in *D-channel connection error* in *Communication problems* on page 3-52, Section 4.3.4.
  - (5) Make an inquiry to the maker of the Switching equipment.

---

**##1007 [TX/RX] a) Call awarded and being delivered in an established channel.**

**b) Call identity not exist.**

---

**Cause a):** Indicated above

- Solutions a):**
- (1) Wait a while, then re-establish communication.
  - (2) Output a communications analysis list, and analyze it.
  - (3) Make sure the 4 digits of the applicable error code are registered in *#4B ISDN BASIC G4/G3 Fallback* and *Speech Fallback* on page 3-74.
  - (4) Take countermeasures as outlined in *D-channel connection error* in *Communication problems* on page 3-52, Section 4.3.4.
  - (5) Make an inquiry to the maker of the Switching equipment.

**Cause b):** Indicated above

- Solutions b):**
- (1) Re-transmit.
  - (2) Output a communications analysis list, and analyze it.
  - (3) Make sure the 4 digits of the applicable error code are registered in *#4B ISDN BASIC G4/G3 Fallback* and *Speech Fallback* on page 3-74.
  - (4) Take countermeasures as outlined in *D-channel connection error* in *Communication problems* on page 3-52, Section 4.3.4.
  - (5) Make an inquiry to the maker of the Switching equipment.

---

**##1008 [TX/RX] Call identity does not belong to a parked connection.**

**Cause:** Indicated above

- Solutions:**
- (1) Re-establish communication.
  - (2) Output a communications analysis list, and analyze it.
  - (3) Make sure the 4 digits of the applicable error code are registered in *#4B ISDN BASIC G4/G3 Fallback* and *Speech Fallback* on page 3-74.
  - (4) Take countermeasures as outlined in *D-channel connection error* in *Communication problems* on page 3-52, Section 4.3.4.
  - (5) Make an inquiry to the maker of the Switching equipment.

**##1010 [TX/RX] Unknown Facility-Code (Code for service characteristic).**

---

**Cause:** Indicated above

- Solutions:**
- (1) Re-transmit.
  - (2) Output a communications analysis list, and analyze it.
  - (3) Make sure the 4 digits of the applicable error code are registered in *#4B ISDN BASIC G4/G3 Fallback and Speech Fallback on page 3-74.*
  - (4) Take countermeasures as outlined in *D-channel connection error in Communication problems on page 3-52, Section 4.3.4.*
  - (5) Make an inquiry to the maker of the Switching equipment.

**##1016 [TX/RX] a) Normal call clearing user busy.**

**b) No basic channel free.**

---

**Cause a):** Indicated above

- Solutions a):**
- (1) Re-establish communication.
  - (2) Output a communications analysis list, and analyze it.
  - (3) Make sure the 4 digits of the applicable error code are registered in *#4B ISDN BASIC G4/G3 Fallback and Speech Fallback on page 3-74.*
  - (4) Take countermeasures as outlined in *D-channel connection error in Communication problems on page 3-52, Section 4.3.4.*
  - (5) Make an inquiry to the maker of the Switching equipment.

**Cause b):** Indicated above

- Solutions b):**
- (1) Re-transmit.
  - (2) Output a communications analysis list, and analyze it.
  - (3) Make sure the 4 digits of the applicable error code are registered in *#4B ISDN BASIC G4/G3 Fallback and Speech Fallback on page 3-74.*
  - (4) Take countermeasures as outlined in *D-channel connection error in Communication problems on page 3-52, Section 4.3.4.*
  - (5) Make an inquiry to the maker of the Switching equipment.

**##1017 [TX/RX] a) User busy.**

**b) No approval for requested service characteristic.**

---

**Cause a):** Indicated above

- Solutions a):**
- (1) Wait a while, then re-transmit.
  - (2) Output a communications analysis list, and analyze it.
  - (3) Make sure the 4 digits of the applicable error code are registered in *#4B ISDN BASIC G4/G3 Fallback and Speech Fallback on page 3-74.*
  - (4) Take countermeasures as outlined in *D-channel connection error in Communication problems on page 3-52, Section 4.3.4.*
  - (5) Make an inquiry to the maker of the Switching equipment.

**Cause b):** Indicated above

- Solutions b):**
- (1) Re-transmit.
  - (2) Output a communications analysis list, and analyze it.
  - (3) Make sure the 4 digits of the applicable error code are registered in *#4B ISDN BASIC G4/G3 Fallback and Speech Fallback on page 3-74.*
  - (4) Take countermeasures as outlined in *D-channel connection error in Communication problems on page 3-52, Section 4.3.4.*
  - (5) Make an inquiry to the maker of the Switching equipment.

**##1018 [TX/RX] No user responding**

---

- Cause:** Indicated above
- Solutions:**
- (1) Re-transmit.
  - (2) Make sure that the other party's machine is plugged in and connected to the line.
  - (3) Output a communications analysis list, and analyze it.
  - (4) Make sure the 4 digits of the applicable error code are registered in *#4B ISDN BASIC G4/G3 Fallback* and *Speech Fallback* on page 3-74.
  - (5) Take countermeasures as outlined in *D-channel connection error* in *Communication problems* on page 3-52, Section 4.3.4.
  - (6) Make an inquiry to the maker of the Switching equipment.

**##1019 [TX/RX] No answer from user (user alerted).**

---

- Cause:** Indicated above
- Solutions:**
- (1) Wait a while, then re-transmit.
  - (2) Output a communications analysis list, and analyze it.
  - (3) Make sure the 4 digits of the applicable error code are registered in *#4B ISDN BASIC G4/G3 Fallback* and *Speech Fallback* on page 3-74.
  - (4) Take countermeasures as outlined in *D-channel connection error* in *Communication problems* on page 3-52, Section 4.3.4.
  - (5) Make an inquiry to the maker of the Switching equipment.

**##1021 [TX/RX] Call rejected**

---

- Cause:** Indicated above
- Solutions:**
- (1) Re-transmit.
  - (2) Output a communications analysis list, and analyze it.
  - (3) Make sure the 4 digits of the applicable error code are registered in *#4B ISDN BASIC G4/G3 Fallback* and *Speech Fallback* on page 3-74.
  - (4) Take countermeasures as outlined in *D-channel connection error* in *Communication problems* on page 3-52, Section 4.3.4.
  - (5) Make an inquiry to the maker of the Switching equipment.

**##1022 [TX/RX] Number changed.**

---

- Cause:** Indicated above
- Solutions:**
- (1) Re-check the phone number and try the call again.
  - (2) Output a communications analysis list, and analyze it.
  - (3) Make sure the 4 digits of the applicable error code are registered in *#4B ISDN BASIC G4/G3 Fallback* and *Speech Fallback* on page 3-74.
  - (4) Take countermeasures as outlined in *D-channel connection error* in *Communication problems* on page 3-52, Section 4.3.4.
  - (5) Make an inquiry to the maker of the Switching equipment.

**##1026 [TX/RX] Non-selected user cleaning.**

---

**Cause:** Indicated above

- Solutions:**
- (1) Re-establish communication.
  - (2) Output a communications analysis list, and analyze it.
  - (3) Make sure the 4 digits of the applicable error code are registered in *#4B ISDN BASIC G4/G3 Fallback* and *Speech Fallback* on page 3-74.
  - (4) Take countermeasures as outlined in *D-channel connection error* in *Communication problems* on page 3-52, Section 4.3.4.
  - (5) Make an inquiry to the maker of the Switching equipment.

**##1027 [TX/RX] Destination out of order.**

---

**Cause:** Indicated above

- Solutions:**
- (1) Inquire as to whether or not the other party's machine can be used.
  - (2) Output a communications analysis list, and analyze it.
  - (3) Make sure the 4 digits of the applicable error code are registered in *#4B ISDN BASIC G4/G3 Fallback* and *Speech Fallback* on page 3-74.
  - (4) Take countermeasures as outlined in *D-channel connection error* in *Communication problems* on page 3-52, Section 4.3.4.
  - (5) Make an inquiry to the maker of the Switching equipment.

**##1028 [TX/RX] Invalid number format.**

---

**Cause:** Indicated above

- Solutions:**
- (1) Check the phone number, and re-transmit.
  - (2) Output a communications analysis list, and analyze it.
  - (3) Make sure the 4 digits of the applicable error code are registered in *#4B ISDN BASIC G4/G3 Fallback* and *Speech Fallback* on page 3-74.
  - (4) Take countermeasures as outlined in *D-channel connection error* in *Communication problems* on page 3-52, Section 4.3.4.
  - (5) Make an inquiry to the maker of the Switching equipment.

**##1029 [TX/RX] Facility rejected.**

---

**Cause:** Indicated above

- Solutions:**
- (1) Re-check the designated service contract.
  - (2) Output a communications analysis list, and analyze it.
  - (3) Make sure the 4 digits of the applicable error code are registered in *#4B ISDN BASIC G4/G3 Fallback* and *Speech Fallback* on page 3-74.
  - (4) Take countermeasures as outlined in *D-channel connection error* in *Communication problems* on page 3-52, Section 4.3.4.
  - (5) Make an inquiry to the maker of the Switching equipment.

**##1030 [TX/RX] Response to status enquiry.**

---

- Cause:** Indicated above
- Solutions:**
- (1) Re-establish communication.
  - (2) Output a communications analysis list, and analyze it.
  - (3) Make sure the 4 digits of the applicable error code are registered in *#4B ISDN BASIC G4/G3 Fallback* and *Speech Fallback* on page 3-74.
  - (4) Take countermeasures as outlined in *D-channel connection error* in *Communication problems* on page 3-52, Section 4.3.4.
  - (5) Make an inquiry to the maker of the Switching equipment.

**##1031 [TX/RX] Normal, unspecified.**

---

- Cause:** Indicated above
- Solutions:**
- (1) Re-establish communication.
  - (2) Output a communications analysis list, and analyze it.
  - (3) Make sure the 4 digits of the applicable error code are registered in *#4B ISDN BASIC G4/G3 Fallback* and *Speech Fallback* on page 3-74.
  - (4) Take countermeasures as outlined in *D-channel connection error* in *Communication problems* on page 3-52, Section 4.3.4.
  - (5) Make an inquiry to the maker of the Switching equipment.

**##1032 [TX/RX] Look of outgoing connection**

---

- Cause:** Indicated above
- Solutions:**
- (1) Re-establish communication.
  - (2) Output a communications analysis list, and analyze it.
  - (3) Make sure the 4 digits of the applicable error code are registered in *#4B ISDN BASIC G4/G3 Fallback* and *Speech Fallback* on page 3-74.
  - (4) Take countermeasures as outlined in *D-channel connection error* in *Communication problems* on page 3-52, Section 4.3.4.
  - (5) Make an inquiry to the maker of the Switching equipment.

**##1033 [TX/RX] Other party is busy**

---

- Cause:** Indicated above
- Solutions:**
- (1) Re-transmit.
  - (2) Output a communications analysis list, and analyze it.
  - (3) Make sure the 4 digits of the applicable error code are registered in *#4B ISDN BASIC G4/G3 Fallback* and *Speech Fallback* on page 3-74.
  - (4) Take countermeasures as outlined in *D-channel connection error* in *Communication problems* on page 3-52, Section 4.3.4.
  - (5) Make an inquiry to the maker of the Switching equipment.



**##1034 [TX/RX] a) No circuit/channel available**

**b) No access to a closed user group.**

---

**Cause a):** Indicated above

- Solutions a):**
- (1) Wait a while, then re-transmit, because the other party's machine is busy.
  - (2) Output a communications analysis list, and analyze it.
  - (3) Make sure the 4 digits of the applicable error code are registered in *#4B ISDN BASIC G4/G3 Fallback* and *Speech Fallback* on page 3-74.
  - (4) Take countermeasures as outlined in *D-channel connection error* in *Communication problems* on page 3-52, Section 4.3.4.
  - (5) Make an inquiry to the maker of the Switching equipment.

**Cause b):** Indicated above

- Solutions b):**
- (1) Re-establish communication.
  - (2) Output a communications analysis list, and analyze it.
  - (3) Make sure the 4 digits of the applicable error code are registered in *#4B ISDN BASIC G4/G3 Fallback* and *Speech Fallback* on page 3-74.
  - (4) Take countermeasures as outlined in *D-channel connection error* in *Communication problems* on page 3-52, Section 4.3.4.
  - (5) Make an inquiry to the maker of the Switching equipment.

**##1035 [TX/RX] Closed user group does not exist.**

---

**Cause:** Indicated above

- Solutions:**
- (1) Re-confirm with the other party, and then re-transmit.
  - (2) Output a communications analysis list, and analyze it.
  - (3) Make sure the 4 digits of the applicable error code are registered in *#4B ISDN BASIC G4/G3 Fallback* and *Speech Fallback* on page 3-74.
  - (4) Take countermeasures as outlined in *D-channel connection error* in *Communication problems* on page 3-52, Section 4.3.4.
  - (5) Make an inquiry to the maker of the Switching equipment.

**##1038 [TX/RX] Network out of order**

---

**Cause:** Indicated above

- Solutions:**
- (1) Wait a while and then re-transmit, because there is a network obstacle has occurred.
  - (2) Output a communications analysis list, and analyze it.
  - (3) Make sure the 4 digits of the applicable error code are registered in *#4B ISDN BASIC G4/G3 Fallback* and *Speech Fallback* on page 3-74.
  - (4) Take countermeasures as outlined in *D-channel connection error* in *Communication problems* on page 3-52, Section 4.3.4.
  - (5) Make an inquiry to the maker of the Switching equipment.

**##1041 [TX/RX] Temporary failure**

---

- Cause:** Indicated above
- Solutions:**
- (1) Wait a while, then re-establish communication.
  - (2) Output a communications analysis list, and analyze it.
  - (3) Make sure the 4 digits of the applicable error code are registered in *#4B ISDN BASIC G4/G3 Fallback* and *Speech Fallback* on page 3-74.
  - (4) Take countermeasures as outlined in *D-channel connection error* in *Communication problems* on page 3-52, Section 4.3.4.
  - (5) Make an inquiry to the maker of the Switching equipment.

**##1042 [TX/RX] Switching equipment congestion**

---

- Cause:** Indicated above
- Solutions:**
- (1) Wait a while, then re-establish communication.
  - (2) Output a communications analysis list, and analyze it.
  - (3) Make sure the 4 digits of the applicable error code are registered in *#4B ISDN BASIC G4/G3 Fallback* and *Speech Fallback* on page 3-74.
  - (4) Take countermeasures as outlined in *D-channel connection error* in *Communication problems* on page 3-52, Section 4.3.4.
  - (5) Make an inquiry to the maker of the Switching equipment.

**##1043 [TX/RX] Access information discarded**

---

- Cause:** Indicated above
- Solutions:**
- (1) Re-establish communication.
  - (2) Output a communications analysis list, and analyze it.
  - (3) Make sure the 4 digits of the applicable error code are registered in *#4B ISDN BASIC G4/G3 Fallback* and *Speech Fallback* on page 3-74.
  - (4) Take countermeasures as outlined in *D-channel connection error* in *Communication problems* on page 3-52, Section 4.3.4.
  - (5) Make an inquiry to the maker of the Switching equipment.

**##1044 [TX/RX] Requested circuit/channel not available**

---

- Cause:** Indicated above
- Solutions:**
- (1) Re-transmit.
  - (2) Output a communications analysis list, and analyze it.
  - (3) Make sure the 4 digits of the applicable error code are registered in *#4B ISDN BASIC G4/G3 Fallback* and *Speech Fallback* on page 3-74.
  - (4) Take countermeasures as outlined in *D-channel connection error* in *Communication problems* on page 3-52, Section 4.3.4.
  - (5) Make an inquiry to the maker of the Switching equipment.

**##1047 [TX/RX] Resources unavailable, unspecified**

---

**Cause:** Indicated above

- Solutions:**
- (1) Re-establish communication.
  - (2) Output a communications analysis list, and analyze it.
  - (3) Make sure the 4 digits of the applicable error code are registered in *#4B ISDN BASIC G4/G3 Fallback* and *Speech Fallback* on page 3-74.
  - (4) Take countermeasures as outlined in *D-channel connection error* in *Communication problems* on page 3-52, Section 4.3.4.
  - (5) Make an inquiry to the maker of the Switching equipment.

**##1049 [TX/RX] Quality of service unavailable**

---

**Cause:** Indicated above

- Solutions:**
- (1) Re-establish communication.
  - (2) Output a communications analysis list, and analyze it.
  - (3) Make sure the 4 digits of the applicable error code are registered in *#4B ISDN BASIC G4/G3 Fallback* and *Speech Fallback* on page 3-74.
  - (4) Take countermeasures as outlined in *D-channel connection error* in *Communication problems* on page 3-52, Section 4.3.4.
  - (5) Make an inquiry to the maker of the Switching equipment.

**##1050 [TX/RX] Requested facility not subscribed**

---

**Cause:** Indicated above

- Solutions:**
- (1) Re-check the contract, and re-establish communication.
  - (2) Output a communications analysis list, and analyze it.
  - (3) Make sure the 4 digits of the applicable error code are registered in *#4B ISDN BASIC G4/G3 Fallback* and *Speech Fallback* on page 3-74.
  - (4) Take countermeasures as outlined in *D-channel connection error* in *Communication problems* on page 3-52, Section 4.3.4.
  - (5) Make an inquiry to the maker of the Switching equipment.

**##1053 [TX/RX] No connection inside the net possible**

---

**Cause:** Indicated above

- Solutions:**
- (1) Re-establish communication.
  - (2) Output a communications analysis list, and analyze it.
  - (3) Make sure the 4 digits of the applicable error code are registered in *#4B ISDN BASIC G4/G3 Fallback* and *Speech Fallback* on page 3-74.
  - (4) Take countermeasures as outlined in *D-channel connection error* in *Communication problems* on page 3-52, Section 4.3.4.
  - (5) Make an inquiry to the maker of the Switching equipment.

**##1056 [TX/RX] The calling number of the wished connection has been changed**

---

- Cause:** Indicated above
- Solutions:**
- (1) Re-check the telephone number, then re-transmit.
  - (2) Output a communications analysis list, and analyze it.
  - (3) Make sure the 4 digits of the applicable error code are registered in *#4B ISDN BASIC G4/G3 Fallback* and *Speech Fallback* on page 3-74.
  - (4) Take countermeasures as outlined in *D-channel connection error* in *Communication problems* on page 3-52, Section 4.3.4.
  - (5) Make an inquiry to the maker of the Switching equipment.

**##1057 [TX/RX] a) Bearer capability not authorized  
b) Called terminal not operational**

---

- Cause a):** Indicated above
- Solutions a):**
- (1) Re-check the contract, and re-transmit.
  - (2) Output a communications analysis list, and analyze it.
  - (3) Make sure the 4 digits of the applicable error code are registered in *#4B ISDN BASIC G4/G3 Fallback* and *Speech Fallback* on page 3-74.
  - (4) Take countermeasures as outlined in *D-channel connection error* in *Communication problems* on page 3-52, Section 4.3.4.
  - (5) Make an inquiry to the maker of the Switching equipment.
- Cause b):** Indicated above
- Solutions b):**
- (1) Inquire to the other party whether the terminal can be used, then re-transmit.
  - (2) Output a communications analysis list, and analyze it.
  - (3) Make sure the 4 digits of the applicable error code are registered in *#4B ISDN BASIC G4/G3 Fallback* and *Speech Fallback* on page 3-74.
  - (4) Take countermeasures as outlined in *D-channel connection error* in *Communication problems* on page 3-52, Section 4.3.4.
  - (5) Make an inquiry to the maker of the Switching equipment.

**##1058 [TX/RX] a) Bearer capability not presently available  
b) Call has not been accessed, break down through time-out**

---

- Cause a):** Indicated above
- Solutions a):**
- (1) Re-check the contract, and re-transmit.
  - (2) Output a communications analysis list, and analyze it.
  - (3) Make sure the 4 digits of the applicable error code are registered in *#4B ISDN BASIC G4/G3 Fallback* and *Speech Fallback* on page 3-74.
  - (4) Take countermeasures as outlined in *D-channel connection error* in *Communication problems* on page 3-52, Section 4.3.4.
  - (5) Make an inquiry to the maker of the Switching equipment.
- Cause b):** Indicated above
- Solutions b):**
- (1) Re-check the telephone number, then re-establish communication.
  - (2) Output a communications analysis list, and analyze it.
  - (3) Make sure the 4 digits of the applicable error code are registered in *#4B ISDN BASIC G4/G3 Fallback* and *Speech Fallback* on page 3-74.
  - (4) Take countermeasures as outlined in *D-channel connection error* in *Communication problems* on page 3-52, Section 4.3.4.
  - (5) Make an inquiry to the maker of the Switching equipment.

**##1059 [TX/RX] Called party is busy (all B-channel are occupied)**

**Cause:** Indicated above

- Solutions:**
- (1) Wait a while, then re-transmit.
  - (2) Output a communications analysis list, and analyze it.
  - (3) Make sure the 4 digits of the applicable error code are registered in *#4B ISDN BASIC G4/G3 Fallback* and *Speech Fallback* on page 3-74.
  - (4) Take countermeasures as outlined in *D-channel connection error* in *Communication problems* on page 3-52, Section 4.3.4.
  - (5) Make an inquiry to the maker of the Switching equipment.

**##1060 [TX/RX] Disconnection from network**

**Cause:** Indicated above

- Solutions:**
- (1) Re-check the phone number and try the call again.
  - (2) Output a communications analysis list, and analyze it.
  - (3) Make sure the 4 digits of the applicable error code are registered in *#4B ISDN BASIC G4/G3 Fallback* and *Speech Fallback* on page 3-74.
  - (4) Take countermeasures as outlined in *D-channel connection error* in *Communication problems* on page 3-52, Section 4.3.4.
  - (5) Make an inquiry to the maker of the Switching equipment.

**##1061 [TX/RX] Called party is closed or does not support the service**

**Cause:** Indicated above

- Solutions:**
- (1) Designated number/Re-check the contract, and re-transmit.
  - (2) Output a communications analysis list, and analyze it.
  - (3) Make sure the 4 digits of the applicable error code are registered in *#4B ISDN BASIC G4/G3 Fallback* and *Speech Fallback* on page 3-74.
  - (4) Take countermeasures as outlined in *D-channel connection error* in *Communication problems* on page 3-52, Section 4.3.4.
  - (5) Make an inquiry to the maker of the Switching equipment.

**##1062 [TX/RX] a) Active rejection of connection through the called party**

**b) Disconnection from network**

**Cause a):** Indicated above

- Solutions a):**
- (1) Re-check the telephone number, then re-transmit.
  - (2) Output a communications analysis list, and analyze it.
  - (3) Make sure the 4 digits of the applicable error code are registered in *#4B ISDN BASIC G4/G3 Fallback* and *Speech Fallback* on page 3-74.
  - (4) Take countermeasures as outlined in *D-channel connection error* in *Communication problems* on page 3-52, Section 4.3.4.
  - (5) Make an inquiry to the maker of the Switching equipment.

**Cause b):** Indicated above

- Solutions b):**
- (1) Re-check the telephone number, then re-establish communication.
  - (2) Output a communications analysis list, and analyze it.
  - (3) Make sure the 4 digits of the applicable error code are registered in *#4B ISDN BASIC G4/G3 Fallback* and *Speech Fallback* on page 3-74.
  - (4) Take countermeasures as outlined in *D-channel connection error* in *Communication problems* on page 3-52, Section 4.3.4.
  - (5) Make an inquiry to the maker of the Switching equipment.

**##1063 [TX/RX] Service or option not available, unspecified.**

---

- Cause:** Indicated above
- Solutions:**
- (1) Re-check the designated service contract, and re-establish communication.
  - (2) Output a communications analysis list, and analyze it.
  - (3) Make sure the 4 digits of the applicable error code are registered in *#4B ISDN BASIC G4/G3 Fallback* and *Speech Fallback* on page 3-74.
  - (4) Take countermeasures as outlined in *D-channel connection error* in *Communication problems* on page 3-52, Section 4.3.4.
  - (5) Make an inquiry to the maker of the Switching equipment.

**##1065 [TX/RX] Bearer capability not implemented**

---

- Cause:** Indicated above
- Solutions:**
- (1) Re-check the designated service contract, and re-transmit.
  - (2) Output a communications analysis list, and analyze it.
  - (3) Make sure the 4 digits of the applicable error code are registered in *#4B ISDN BASIC G4/G3 Fallback* and *Speech Fallback* on page 3-74.
  - (4) Take countermeasures as outlined in *D-channel connection error* in *Communication problems* on page 3-52, Section 4.3.4.
  - (5) Make an inquiry to the maker of the Switching equipment.

**##1066 [TX/RX] Non-supplied channel classification designated**

---

- Cause:** Indicated above
- Solutions:**
- (1) Re-check the designated service contract, and re-transmit.
  - (2) Output a communications analysis list, and analyze it.
  - (3) Make sure the 4 digits of the applicable error code are registered in *#4B ISDN BASIC G4/G3 Fallback* and *Speech Fallback* on page 3-74.
  - (4) Take countermeasures as outlined in *D-channel connection error* in *Communication problems* on page 3-52, Section 4.3.4.
  - (5) Make an inquiry to the maker of the Switching equipment.

**##1069 [TX/RX] Channel type not implemented**

---

- Cause:** Indicated above
- Solutions:**
- (1) Re-check the designated service contract, and re-transmit.
  - (2) Output a communications analysis list, and analyze it.
  - (3) Make sure the 4 digits of the applicable error code are registered in *#4B ISDN BASIC G4/G3 Fallback* and *Speech Fallback* on page 3-74.
  - (4) Take countermeasures as outlined in *D-channel connection error* in *Communication problems* on page 3-52, Section 4.3.4.
  - (5) Make an inquiry to the maker of the Switching equipment.

**##1070 [TX/RX] Only restricted digital information bearer capability is available**

---

**Cause:** Indicated above

- Solutions:**
- (1) Re-transmit.
  - (2) Output a communications analysis list, and analyze it.
  - (3) Make sure the 4 digits of the applicable error code are registered in *#4B ISDN BASIC G4/G3 Fallback* and *Speech Fallback* on page 3-74.
  - (4) Take countermeasures as outlined in *D-channel connection error* in *Communication problems* on page 3-52, Section 4.3.4.
  - (5) Make an inquiry to the maker of the Switching equipment.

**##1079 [TX/RX] Service or option not implemented, unspecified**

---

**Cause:** Indicated above

- Solutions:**
- (1) Re-check the designated service contract, and re-establish communication.
  - (2) Output a communications analysis list, and analyze it.
  - (3) Make sure the 4 digits of the applicable error code are registered in *#4B ISDN BASIC G4/G3 Fallback* and *Speech Fallback* on page 3-74.
  - (4) Take countermeasures as outlined in *D-channel connection error* in *Communication problems* on page 3-52, Section 4.3.4.
  - (5) Make an inquiry to the maker of the Switching equipment.

**##1081 [TX/RX] Invalid call reference value**

---

**Cause:** Indicated above

- Solutions:**
- (1) Re-establish communication.
  - (2) Output a communications analysis list, and analyze it.
  - (3) Make sure the 4 digits of the applicable error code are registered in *#4B ISDN BASIC G4/G3 Fallback* and *Speech Fallback* on page 3-74.
  - (4) Take countermeasures as outlined in *D-channel connection error* in *Communication problems* on page 3-52, Section 4.3.4.
  - (5) Make an inquiry to the maker of the Switching equipment.

**##1082 [TX/RX] Identified channel does not exist**

---

**Cause:** Indicated above

- Solutions:**
- (1) Re-transmit.
  - (2) Output a communications analysis list, and analyze it.
  - (3) Make sure the 4 digits of the applicable error code are registered in *#4B ISDN BASIC G4/G3 Fallback* and *Speech Fallback* on page 3-74.
  - (4) Take countermeasures as outlined in *D-channel connection error* in *Communication problems* on page 3-52, Section 4.3.4.
  - (5) Make an inquiry to the maker of the Switching equipment.

**##1083 [TX/RX] A suspended call exists, but this call identity does not**

---

- Cause:** Indicated above
- Solutions:**
- (1) Re-establish communication.
  - (2) Output a communications analysis list, and analyze it.
  - (3) Make sure the 4 digits of the applicable error code are registered in *#4B ISDN BASIC G4/G3 Fallback* and *Speech Fallback* on page 3-74.
  - (4) Take countermeasures as outlined in *D-channel connection error* in *Communication problems* on page 3-52, Section 4.3.4.
  - (5) Make an inquiry to the maker of the Switching equipment.

**##1084 [TX/RX] Call identity in use**

---

- Cause:** Indicated above
- Solutions:**
- (1) Re-establish communication.
  - (2) Output a communications analysis list, and analyze it.
  - (3) Make sure the 4 digits of the applicable error code are registered in *#4B ISDN BASIC G4/G3 Fallback* and *Speech Fallback* on page 3-74.
  - (4) Take countermeasures as outlined in *D-channel connection error* in *Communication problems* on page 3-52, Section 4.3.4.
  - (5) Make an inquiry to the maker of the Switching equipment.

**##1085 [TX/RX] No call suspended**

---

- Cause:** Indicated above
- Solutions:**
- (1) Re-establish communication.
  - (2) Output a communications analysis list, and analyze it.
  - (3) Make sure the 4 digits of the applicable error code are registered in *#4B ISDN BASIC G4/G3 Fallback* and *Speech Fallback* on page 3-74.
  - (4) Take countermeasures as outlined in *D-channel connection error* in *Communication problems* on page 3-52, Section 4.3.4.
  - (5) Make an inquiry to the maker of the Switching equipment.

**##1086 [TX/RX] Call having the requested call identity has been cleared**

---

- Cause:** Indicated above
- Solutions:**
- (1) Re-establish communication.
  - (2) Output a communications analysis list, and analyze it.
  - (3) Make sure the 4 digits of the applicable error code are registered in *#4B ISDN BASIC G4/G3 Fallback* and *Speech Fallback* on page 3-74.
  - (4) Take countermeasures as outlined in *D-channel connection error* in *Communication problems* on page 3-52, Section 4.3.4.
  - (5) Make an inquiry to the maker of the Switching equipment.



**##1088 [TX/RX] Incompatible destination**

---

**Cause:** Indicated above

- Solutions:**
- (1) Re-check the other party's terminal type, then re-transmit.
  - (2) Output a communications analysis list, and analyze it.
  - (3) Make sure the 4 digits of the applicable error code are registered in *#4B ISDN BASIC G4/G3 Fallback* and *Speech Fallback* on page 3-74.
  - (4) Take countermeasures as outlined in *D-channel connection error* in *Communication problems* on page 3-52, Section 4.3.4.
  - (5) Make an inquiry to the maker of the Switching equipment.

**##1089 [TX/RX] Line busy**

---

**Cause:** Indicated above

- Solutions:**
- (1) Re-transmit.
  - (2) Output a communications analysis list, and analyze it.
  - (3) Make sure the 4 digits of the applicable error code are registered in *#4B ISDN BASIC G4/G3 Fallback* and *Speech Fallback* on page 3-74.
  - (4) Take countermeasures as outlined in *D-channel connection error* in *Communication problems* on page 3-52, Section 4.3.4.
  - (5) Make an inquiry to the maker of the Switching equipment.

**##1090 [TX/RX] Release from the other party number or from a distant exchange**

---

**Cause:** Indicated above

- Solutions:**
- (1) Re-establish communication.
  - (2) Output a communications analysis list, and analyze it.
  - (3) Make sure the 4 digits of the applicable error code are registered in *#4B ISDN BASIC G4/G3 Fallback* and *Speech Fallback* on page 3-74.
  - (4) Take countermeasures as outlined in *D-channel connection error* in *Communication problems* on page 3-52, Section 4.3.4.
  - (5) Make an inquiry to the maker of the Switching equipment.

**##1091 [TX/RX] Invalid transit network selection**

---

**Cause:** Indicated above

- Solutions:**
- (1) Re-check the designated relay network, and re-transmit.
  - (2) Output a communications analysis list, and analyze it.
  - (3) Make sure the 4 digits of the applicable error code are registered in *#4B ISDN BASIC G4/G3 Fallback* and *Speech Fallback* on page 3-74.
  - (4) Take countermeasures as outlined in *D-channel connection error* in *Communication problems* on page 3-52, Section 4.3.4.
  - (5) Make an inquiry to the maker of the Switching equipment.

**##1092 [TX/RX] Disconnection from network**

---

- Cause:** Indicated above
- Solutions:**
- (1) Re-check the phone number and try the call again.
  - (2) Output a communications analysis list, and analyze it.
  - (3) Make sure the 4 digits of the applicable error code are registered in *#4B ISDN BASIC G4/G3 Fallback* and *Speech Fallback* on page 3-74.
  - (4) Take countermeasures as outlined in *D-channel connection error* in *Communication problems* on page 3-52, Section 4.3.4.
  - (5) Make an inquiry to the maker of the Switching equipment.

**##1095 [TX/RX] Invalid message, unspecified**

---

- Cause:** Indicated above
- Solutions:**
- (1) Re-establish communication.
  - (2) Output a communications analysis list, and analyze it.
  - (3) Make sure the 4 digits of the applicable error code are registered in *#4B ISDN BASIC G4/G3 Fallback* and *Speech Fallback* on page 3-74.
  - (4) Take countermeasures as outlined in *D-channel connection error* in *Communication problems* on page 3-52, Section 4.3.4.
  - (5) Make an inquiry to the maker of the Switching equipment.

**##1096 [TX/RX] Mandatory information element is missing**

---

- Cause:** Indicated above
- Solutions:**
- (1) Re-establish communication.
  - (2) Output a communications analysis list, and analyze it.
  - (3) Make sure the 4 digits of the applicable error code are registered in *#4B ISDN BASIC G4/G3 Fallback* and *Speech Fallback* on page 3-74.
  - (4) Take countermeasures as outlined in *D-channel connection error* in *Communication problems* on page 3-52, Section 4.3.4.
  - (5) Make an inquiry to the maker of the Switching equipment.

**##1097 [TX/RX] Message type non-existent or not implemented**

---

- Cause:** Indicated above
- Solutions:**
- (1) Re-check the designated service contract, and re-establish communication.
  - (2) Output a communications analysis list, and analyze it.
  - (3) Make sure the 4 digits of the applicable error code are registered in *#4B ISDN BASIC G4/G3 Fallback* and *Speech Fallback* on page 3-74.
  - (4) Take countermeasures as outlined in *D-channel connection error* in *Communication problems* on page 3-52, Section 4.3.4.
  - (5) Make an inquiry to the maker of the Switching equipment.

**##1098 [TX/RX] Message not compatible with call state or message type non-existent or not**

---

**Cause:** Indicated above

- Solutions:**
- (1) Re-establish communication.
  - (2) Output a communications analysis list, and analyze it.
  - (3) Make sure the 4 digits of the applicable error code are registered in *#4B ISDN BASIC G4/G3 Fallback* and *Speech Fallback* on page 3-74.
  - (4) Take countermeasures as outlined in *D-channel connection error* in *Communication problems* on page 3-52, Section 4.3.4.
  - (5) Make an inquiry to the maker of the Switching equipment.

**##1099 [TX/RX] Information element non-existent or not implemented**

---

**Cause:** Indicated above

- Solutions:**
- (1) Re-establish communication.
  - (2) Output a communications analysis list, and analyze it.
  - (3) Make sure the 4 digits of the applicable error code are registered in *#4B ISDN BASIC G4/G3 Fallback* and *Speech Fallback* on page 3-74.
  - (4) Take countermeasures as outlined in *D-channel connection error* in *Communication problems* on page 3-52, Section 4.3.4.
  - (5) Make an inquiry to the maker of the Switching equipment.

**##1100 [TX/RX] Invalid information element contents**

---

**Cause:** Indicated above

- Solutions:**
- (1) Re-establish communication.
  - (2) Output a communications analysis list, and analyze it.
  - (3) Make sure the 4 digits of the applicable error code are registered in *#4B ISDN BASIC G4/G3 Fallback* and *Speech Fallback* on page 3-74.
  - (4) Take countermeasures as outlined in *D-channel connection error* in *Communication problems* on page 3-52, Section 4.3.4.
  - (5) Make an inquiry to the maker of the Switching equipment.

**##1101 [TX/RX] Message not compatible with call state**

---

**Cause:** Indicated above

- Solutions:**
- (1) Re-establish communication.
  - (2) Output a communications analysis list, and analyze it.
  - (3) Make sure the 4 digits of the applicable error code are registered in *#4B ISDN BASIC G4/G3 Fallback* and *Speech Fallback* on page 3-74.
  - (4) Take countermeasures as outlined in *D-channel connection error* in *Communication problems* on page 3-52, Section 4.3.4.
  - (5) Make an inquiry to the maker of the Switching equipment.

**##1102 [TX/RX] Recovery on timer expire**

---

- Cause:** Indicated above
- Solutions:**
- (1) Re-check the designated relay network, and re-establish communication.
  - (2) Output a communications analysis list, and analyze it.
  - (3) Make sure the 4 digits of the applicable error code are registered in *#4B ISDN BASIC G4/G3 Fallback* and *Speech Fallback* on page 3-74.
  - (4) Take countermeasures as outlined in *D-channel connection error* in *Communication problems* on page 3-52, Section 4.3.4.
  - (5) Make an inquiry to the maker of the Switching equipment.

**##1103 [TX/RX] Disconnection from network**

---

- Cause:** Indicated above
- Solutions:**
- (1) Re-check the phone number and try the call again.
  - (2) Output a communications analysis list, and analyze it.
  - (3) Make sure the 4 digits of the applicable error code are registered in *#4B ISDN BASIC G4/G3 Fallback* and *Speech Fallback* on page 3-74.
  - (4) Take countermeasures as outlined in *D-channel connection error* in *Communication problems* on page 3-52, Section 4.3.4.
  - (5) Make an inquiry to the maker of the Switching equipment.

**##1111 [TX/RX] Protocol error, unspecified**

---

- Cause:** Indicated above
- Solutions:**
- (1) Re-establish communication.
  - (2) Output a communications analysis list, and analyze it.
  - (3) Make sure the 4 digits of the applicable error code are registered in *#4B ISDN BASIC G4/G3 Fallback* and *Speech Fallback* on page 3-74.
  - (4) Take countermeasures as outlined in *D-channel connection error* in *Communication problems* on page 3-52, Section 4.3.4.
  - (5) Make an inquiry to the maker of the Switching equipment.

**##1112 [TX/RX] Release because of error in a local area**

---

- Cause:** Indicated above
- Solutions:**
- (1) Re-establish communication.
  - (2) Output a communications analysis list, and analyze it.
  - (3) Make sure the 4 digits of the applicable error code are registered in *#4B ISDN BASIC G4/G3 Fallback* and *Speech Fallback* on page 3-74.
  - (4) Take countermeasures as outlined in *D-channel connection error* in *Communication problems* on page 3-52, Section 4.3.4.
  - (5) Make an inquiry to the maker of the Switching equipment.

**##1113 [TX/RX] a) Release because of error in a distant area**

**b) Disconnection from network**

---

**Cause a):** Indicated above

- Solutions a):**
- (1) Re-establish communication.
  - (2) Output a communications analysis list, and analyze it.
  - (3) Make sure the 4 digits of the applicable error code are registered in *#4B ISDN BASIC G4/G3 Fallback* and *Speech Fallback* on page 3-74.
  - (4) Take countermeasures as outlined in *D-channel connection error* in *Communication problems* on page 3-52, Section 4.3.4.
  - (5) Make an inquiry to the maker of the Switching equipment.

**Cause b):** Indicated above

- Solutions b):**
- (1) Re-establish communication.
  - (2) Output a communications analysis list, and analyze it.
  - (3) Make sure the 4 digits of the applicable error code are registered in *#4B ISDN BASIC G4/G3 Fallback* and *Speech Fallback* on page 3-74.
  - (4) Take countermeasures as outlined in *D-channel connection error* in *Communication problems* on page 3-52, Section 4.3.4.
  - (5) Make an inquiry to the maker of the Switching equipment.

**##1114 [TX/RX] Disconnection from network**

---

**Cause:** Indicated above

- Solutions:**
- (1) Re-check the phone number and try the call again.
  - (2) Output a communications analysis list, and analyze it.
  - (3) Make sure the 4 digits of the applicable error code are registered in *#4B ISDN BASIC G4/G3 Fallback* and *Speech Fallback* on page 3-74.
  - (4) Take countermeasures as outlined in *D-channel connection error* in *Communication problems* on page 3-52, Section 4.3.4.
  - (5) Make an inquiry to the maker of the Switching equipment.

**##1126 [TX/RX] Disconnection from network**

---

**Cause:** Indicated above

- Solutions:**
- (1) Re-check the phone number and try the call again.
  - (2) Output a communications analysis list, and analyze it.
  - (3) Make sure the 4 digits of the applicable error code are registered in *#4B ISDN BASIC G4/G3 Fallback* and *Speech Fallback* on page 3-74.
  - (4) Take countermeasures as outlined in *D-channel connection error* in *Communication problems* on page 3-52, Section 4.3.4.
  - (5) Make an inquiry to the maker of the Switching equipment.

**##1127 [TX/RX] Interworking, unspecified**

---

- Cause:** Indicated above
- Solutions:**
- (1) Re-establish communication.
  - (2) Output a communications analysis list, and analyze it.
  - (3) Make sure the 4 digits of the applicable error code are registered in *#4B ISDN BASIC G4/G3 Fallback* and *Speech Fallback* on page 3-74.
  - (4) Take countermeasures as outlined in *D-channel connection error* in *Communication problems* on page 3-52, Section 4.3.4.
  - (5) Make an inquiry to the maker of the Switching equipment.

**##1130 [TX/RX] D-channel abnormal**

---

- Cause:** Unrecoverable error occurred in D-channel layer 2,3 protocol procedure
- Solutions:**
- (1) Make sure the line correctly connected.
  - (2) Switch the power OFF/ON, then re-transmit.
  - (3) Output a communications analysis list, and analyze it.
  - (4) Make sure the 4 digits of the applicable error code are registered in *#4B ISDN BASIC G4/G3 Fallback* and *Speech Fallback* on page 3-74.
  - (5) Take countermeasures as outlined in *D-channel connection error* in *Communication problems* on page 3-52, Section 4.3.4.
  - (6) Make an inquiry to the maker of the Switching equipment.

**##1131 [TX/RX] D-channel connection monitoring timer timed out**

---

- Cause:** When calling, the connection (disconnection) from the other party expired in a fixed time interval with no response.
- Solutions:**
- (1) Check to see if the other party is absent or whether they are receiving manually.
  - (2) Output a communications analysis list, and analyze it.
  - (3) Make sure the 4 digits of the applicable error code are registered in *#4B ISDN BASIC G4/G3 Fallback* and *Speech Fallback* on page 3-74.
  - (4) Take countermeasures as outlined in *D-channel connection error* in *Communication problems* on page 3-52, Section 4.3.4.
  - (5) Make an inquiry to the maker of the Switching equipment.

• B-channel error codes

**##1255 [RX] B-channel was disconnected without the document being started**

---

**Cause:** After the negotiation procedure on the transmitting side, a disconnection occurred without the document being transmitted.

**Solutions:** (1) Have the transmitted party set the document properly  
(2) Output a communications analysis list, and analyze it.

**##1309 [TX/RX] Abnormal post-reception checkpoint reference number (page number)**

---

**Cause:** The page is completed, and the checkpoint reference number which is the parameter used during CDE, CDPB, RDEP or RDPBP is abnormal (a series of long, non-numeric parameters, etc.)

**Solutions:** (1) Re-establish communication.  
(2) Output a communications analysis list, and analyze it.

**##1321 [TX/RX] 1-page transmission time-out**

---

**Cause:** Indicated above

**Solutions:** (1) Lower the document's transmission resolution, then re-establish communication.  
(2) Output a communications analysis list, and analyze it

**##1322 [RX] Other machine's terminal properties abnormal (session procedures)**

---

**Cause:** As a result of negotiation, the attributes of the terminal which show session user data are abnormal (abnormality in a non-G4 facsimile parameter, etc.)

**Solutions:** (1) Re-establish communication.  
(2) Output a communications analysis list, and analyze it.

**##1323 [TX] RSSN reception**

---

**Cause:** Compared with CSS transmission, the receiving side transmitted RSSN

**Solutions:** (1) Re-transmit  
(2) Output a communications analysis list, and analyze it.

**##1332 [TX/RX] Other terminal's properties are abnormal (Document procedures)**

---

**Cause:** As a result of negotiation, the attributes of the terminal which show session user data are abnormal (abnormality in a non-G4 facsimile parameter, etc.)

**Solutions:** (1) Re-establish communication.  
(2) Output a communications analysis list, and analyze it.

**##1334 [RX] Document attributes abnormal**

---

**Cause:** Attributes of the received page such as size, resolution, and encoding method are abnormal.

**Solutions:** (1) Re-establish communication.  
(2) Output a communications analysis list, and analyze it.

**##1336 [TX/RX] CSA reception**

---

**Cause:** CSA was received from the other machine during transmission

**Solutions:** (1) Check whether the receiving machine's memory is full when transmitting.  
(2) Check whether the other machine's communication process has been stopped.  
(3) Re-establish communication.  
(4) Output a communications analysis list, and analyze it.

**##1337 [RX] Non-transmission monitoring timer (T.62 T1 timer) timed out**

---

**Cause:** Expired in a fixed interval without receiving the data frame from the sending side without the document being transmitted.

- Solutions:**
- (1) Check whether the other party's machine is working properly.
  - (2) Re-establish communication.
  - (3) Output a communications analysis list, and analyze it.

**##1339 [RX] CDR reception**

---

**Cause:** CDR received from the transmitting side with document procedures

- Solutions:**
- (1) Check whether the other party's machine is working properly.
  - (2) Re-establish communication.
  - (3) Output a communications analysis list, and analyze it.

**##1340 [RX] CDD reception**

---

**Cause:** CDD received from the transmitting side with document procedures

- Solutions:**
- (1) Check whether the other party's machine is working properly.
  - (2) Re-establish communication.
  - (3) Output a communications analysis list, and analyze it.

**##1341 [TX] RDPBN reception**

---

**Cause:** RDPBN received from the transmitting side with document procedures  
The page could not be received correctly by the receiving side.

- Solutions:**
- (1) Re-transmit from the page where the error occurred.
  - (2) Output a communications analysis list, and analyze it.

**##1348 [TX/RX] Session layer abnormal (Document procedure)**

---

**Cause:** Underfined document procedure frame received with document properties

- Solutions:**
- (1) Re-establish communication.
  - (2) Output a communications analysis list, and analyze it.

**##1350 [RX] CSS parameter abnormal**

---

**Cause:** Session procedures received, abnormality discovered in CSS contents

- Solutions:**
- (1) Re-establish communication.
  - (2) Output a communications analysis list, and analyze it.

**##1351 [TX] RSSP (RSSN) parameter abnormal**

---

**Cause:** Session procedures received, abnormality discovered in RSSP or RSSN contents

- Solutions:**
- (1) Re-transmit.
  - (2) Output a communications analysis list, and analyze it..

**##1352 [RX] CSE parameter abnormal**

---

**Cause:** Session procedures received, abnormality discovered in CSE contents

- Solutions:**
- (1) Re-establish communication.
  - (2) Output a communications analysis list, and analyze it.



**##1353 [TX] RSEP parameter abnormal**

---

- Cause:** Session procedures received, abnormality discovered in RSEP contents  
**Solutions:** (1) Re-transmit.  
(2) Output a communications analysis list, and analyze it.

**##1354 [RX] CSCC parameter abnormal**

---

- Cause:** Session procedures received, abnormality discovered in CSCC contents  
**Solutions:** (1) Re-establish communication.  
(2) Output a communications analysis list, and analyze it.

**##1355 [TX] RSCCP parameter abnormal**

---

- Cause:** Session procedures received, abnormality discovered in RSCCP contents  
**Solutions:** (1) Re-transmit.  
(2) Output a communications analysis list, and analyze it.

**##1372 [RX] CDS parameter abnormal**

---

- Cause:** Document procedures received, abnormality discovered in CDS contents  
**Solutions:** (1) Have the document set properly on the transmitting side.  
(2) Output a communications analysis list, and analyze it.

**##1373 [RX] CDC parameter abnormal**

---

- Cause:** Document procedures received, abnormality discovered in CDC contents  
**Solutions:** (1) Re-establish communication.  
(2) Output a communications analysis list, and analyze it.

**##1380 [RX] CDE parameter abnormal**

---

- Cause:** Document procedures received, abnormality discovered in CDE contents  
**Solutions:** (1) Re-establish communication.  
(2) Output a communications analysis list, and analyze it.

**##1381 [TX] RDEP parameter abnormal**

---

- Cause:** Document procedures received, abnormality discovered in RDEP contents  
**Solutions:** (1) Re-transmit.  
(2) Output a communications analysis list, and analyze it.

**##1386 [RX] CDPB parameter abnormal**

---

- Cause:** Document procedures received, abnormality discovered in CDPB contents  
**Solutions:** (1) Re-establish communication.  
(2) Output a communications analysis list, and analyze it.

**##1387 [TX] RDPBP parameter abnormal**

---

- Cause:** Document procedures received, abnormality discovered in RDPBP contents  
**Solutions:** (1) Re-transmit.  
(2) Output a communications analysis list, and analyze it.

**##1388 [RX] CDCL parameter abnormal**

---

- Cause:** Document procedures received, abnormality discovered in CDCL contents
- Solutions:**
- (1) Check whether the other party's machine is working properly.
  - (2) Re-establish communication.
  - (3) Output a communications analysis list, and analyze it.

**##1389 [TX] RDCLP parameter abnormal**

---

- Cause:** Document procedures received, abnormality discovered in RDCLP contents
- Solutions:**
- (1) Check whether the transmitting machine has been stopped
  - (2) Re-transmit.
  - (3) Output a communications analysis list, and analyze it.

**##1412 [TX] RDGR transmission**

---

- Cause:** RDGR received during document procedures
- Solutions:**
- (1) Re-transmit.
  - (2) Output a communications analysis list, and analyze it.

**##1413 [TX/RX] Abnormality discovered before session connection**

---

- Cause:** Abnormality discovered in the procedures before session connection (below B-channel layer 4)
- Solutions:**
- (1) Re-establish communication.
  - (2) Output a communications analysis list, and analyze it.

**##1414 [TX/RX] Abnormality discovered in the session procedures after session connection**

---

- Cause:** A frame which could not continue session procedures normally, or an undefined frame was received after session connection
- Solutions:**
- (1) Re-establish communication.
  - (2) Output a communications analysis list, and analyze it.

**##1417 [TX] Monitoring timer time-out with no response (T.62 T2 timer)**

---

- Cause:** Timed out without getting a response (layer 5 frame reception) from the receiving side during transmission
- Solutions:**
- (1) Confirm that the receiving machine is operating normally
  - (2) Re-transmit.
  - (3) Output a communications analysis list, and analyze it.

**##1418 [TX/RX] CSA timer (T.62 T3 timer) time-out**

---

- Cause:** CSA received, or timed-out with no RSAP response
- Solutions:**
- (1) Confirm that the other party's machine is operating normally
  - (2) Re-establish communication.
  - (3) Output a communications analysis list, and analyze it.

**##1420 [TX/RX] Session layer protocol violation**

---

- Cause:** Negotiation made with a session windows size larger than 2  
(Run the machine only with the session windows size set at 1)
- Solutions:**
- (1) Re-establish communication.
  - (2) Output a communications analysis list, and analyze it.
  - (3) Have the other party change the session windows size on their machine

**##1600 [RX] Transmission error in layer 4 or below of B-channel**

---

- Cause:** Session procedures received, abnormality discovered in RSEP contents
- Solutions:**
- (1) Re-transmit.
  - (2) Output a communications analysis list, and analyze it.

**##1601 [TX/RX] Connection parameter abnormalily in layer 4 connection (transport length)**

---

- Cause:** Indicated above
- Solutions:**
- (1) Re-establish communication.
  - (2) Output a communications analysis list, and analyze it.

**##1603 [TX] Abnormal session control function parameter**

---

- Cause:** An abnormality occurred in the session control function parameter which indicates the transmission authority reversal.
- Solutions:**
- (1) Re-transmit.
  - (2) Output a communications analysis list, and analyze it.

**##1608 [RX] P-START abnormality**

---

- Cause:** An abnormality occurred during P-START analysis.
- Solutions:**
- (1) Re-establish communication.
  - (2) Output a communications analysis list, and analyze it.

**##1618 [RX] Error in presentation layer (layer 6)**

---

- Cause:** Error (Image end terminal detection, MMR error) in presentation layer
- Solutions:**
- (1) Re-establish communication.
  - (2) Output a communications analysis list, and analyze it.

**##1620 [RX] D-channel -> B-channel connection timer timed-out**

---

- Cause:** Time-out when receiving with no B-channel connection, even though D-channel was connected
- Solutions:**
- (1) Check whether the other party's machine is working properly.
  - (2) Output a communications analysis list, and analyze it.

## 4.3 Errors not Shown on the Display

### 4.3.1 General errors

- **The unit does not power on. (Evaluation criteria: Look at the actual unit.)**

- (1) Check the power cord connection.
- (2) Check the connection between the PCNT board (J403) and power supply unit.
- (3) Check the connection between the SCNT board (J1) and power supply unit.
- (4) Check the connection between the SCNT board (J8) and PCNT board (J201)
- (5) Check the power supply unit's fuse (FU101).
- (6) Replace the power supply unit.

- **Abnormal display. (Applicable test mode: Operation panel test)**

**Nothing is displayed.**

---

- (1) Check the connection between the operation panel unit and SCNT board (J7).
- (2) Replace the operation panel unit.
- (3) Replace the SCNT board.

**Part of the LCD panel does not display anything.**

---

- (1) Check for LCD problems with the test mode.
- (2) Check the connection between the operation panel unit and SCNT board (J7).
- (3) Replace the operation panel unit. (Faulty LCD)
- (4) Replace the SCNT board.

- **The buttons do not work. (Applicable test mode: Operation panel test)**

- (1) If the test mode can be used, check for faulty buttons.
- (2) Check the connection between the operation panel unit and SCNT board (J7).
- (3) Replace the operation panel unit.
- (4) Replace the SCNT board.

- **No sound from the speaker**

- (1) Check the connection of the speaker and SCNT board (J3).
- (2) Replace the speaker.
- (3) Replace the G4 board.
- (4) Replace the SCNT board.

### 4.3.2 Printing problems

• **Faulty printing (Evaluation criteria: Test print is faulty.)**

• **The paper is not fed correctly. (Evaluation criteria: Look at the actual unit.)**

**The main motor does not run.**

- (1) Check the main motor's resistance. 1.62 ~ 1.98 Ω/1 phase is normal. (Fig. 3-4)
- (2) Replace the main motor.
- (3) Replace the PCNT board.
- (4) Replace the SCNT board.

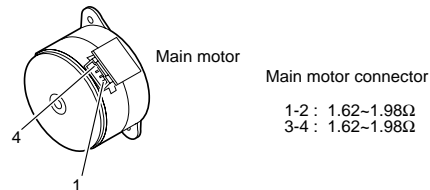

**Figure 3-4 Main Motor Connector**

**The paper is not picked up from the auto sheet feeder.**

- (1) Check whether the recommended paper is used.
- (2) Check whether more than 100 sheets of paper have been loaded in the auto sheet feeder.
- (3) Check whether the paper has been loaded into the sheet feeder correctly.
- (4) Check the connection between the paper pickup solenoid and the power supply unit (J204).
- (5) Replace the paper pickup solenoid.
- (6) Clean the separation pad.
- (7) Replace the separation pad.
- (8) Replace the separation pad spring or the lifting spring.
- (9) Replace the SCNT board.

**The paper skews.**

- (1) Check whether the recommended paper is used.
- (2) Check whether more than 100 sheets of paper have been loaded in the sheet feeder.
- (3) Check whether the paper has been loaded into the sheet feeder correctly.
- (4) Check whether dust or paper debris have built up inside the auto sheet feeder.
- (5) Check whether the paper pickup roller, or any other rollers, are damaged or scratched.

• **The printing operation is abnormal.**

**The unit indicates there is a paper jam when there is no paper jam.**

- (1) Check the connection from the paper edge sensor to the PCNT board (J204).
- (2) Check whether the paper edge sensor and actuator and the paper eject sensor actuator are in their correct positions.
- (3) In test mode check whether the paper edge sensor and the paper eject sensor are operating correctly.
- (4) Check the connection between the main motor and the PCNT board (J401).
- (5) Replace the main motor.
- (6) Replace the PCNT board.
- (7) Replace the SCNT board.

• **Poor printing quality (Evaluation criteria: Check the test print image's faults.)**

Before checking for the cause of print defects, check whether the user uses Canon-recommended paper and stores it correctly. If the problem is solved by using the recommended paper, the customer should be advised to use the recommended paper and store it correctly.

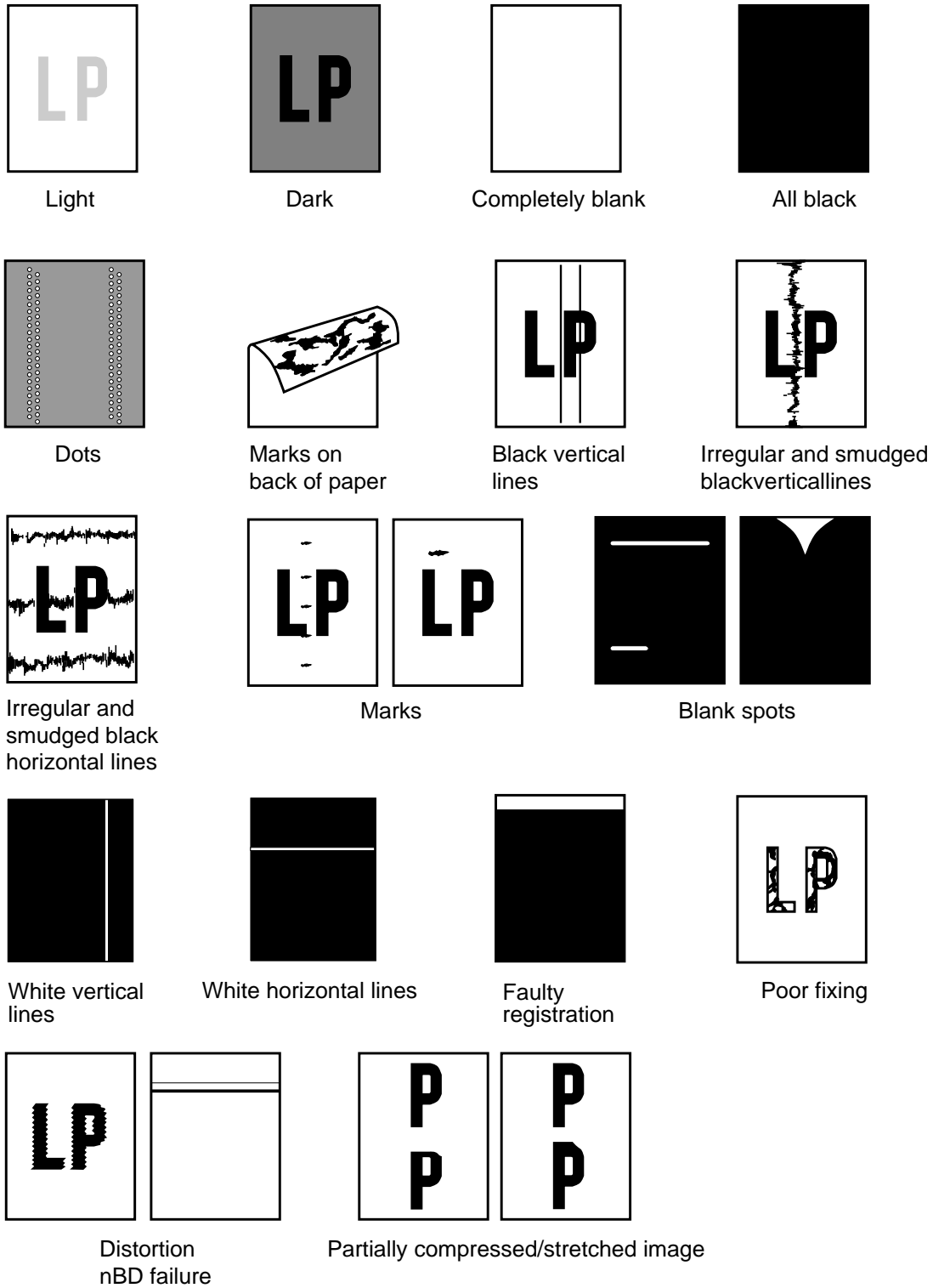

Figure 3-5 Faulty Print Samples

**• Light**

- Solutions:**
- (1) Remove the toner cartridge and shake it lightly five or six times.
  - (2) Verify that user data setting “TONER SAVING” is not “ON”.
  - (3) Replace the toner cartridge.
  - (4) Open the front cover during printing, and remove the toner cartridge. Open the cartridge drum cover shutter manually, and check whether the toner image on the photosensitive drum is transferred onto the paper. If it is transferred, go to item (7). If not, go the following step.
  - (5) Clean the transfer bias contact and the transfer charging roller shaft contact.
  - (6) Replace the transfer charging roller.
  - (7) Clean the developing bias contact and the toner cartridge contact.
  - (8) Replace the PCNT board.
  - (9) Replace the power supply unit.
  - (10) Replace the LASER/scanner section.
  - (11) Replace the SCNT board.

**• Dark**

- Solutions:**
- (1) Verify that user data setting “TONER SAVING” is not “OFF”.
  - (2) Clean the drum ground contact and the toner cartridge contact
  - (3) Clean the primary charging contact and the toner cartridge contact.
  - (4) Replace the LASER/scanner section.
  - (5) Replace the SCNT board.

**• Completely blank**

- Solutions:**
- (1) Clean the developing bias contact and the toner cartridge contact.
  - (2) Check whether the projection for opening and closing the LASER shutter on the toner cartridge is damaged.
  - (3) Check the voltage connector (PCNT : J402) for the high-voltage power circuit.
  - (4) Replace the PCNT board.
  - (5) Replace the power supply unit.
  - (6) Replace the LASER/scanner section.
  - (7) Replace the SCNT board.

**• All black**

- Solutions:**
- (1) Replace the toner cartridge.
  - (2) Clean the primary charging contact and the toner cartridge contact.
  - (3) Replace the PCNT board.
  - (4) Replace the power supply unit
  - (5) Replace the LASER/scanner section.
  - (6) Replace the SCNT board.

**• Dots**

- Solutions:**
- (1) Clean the static charge eliminator in the toner transfer section.
  - (2) Check the static charge eliminator contact.
  - (3) Clean the transfer charging roller.
  - (4) Replace the transfer charging roller.

**• Marks on back of paper**

---

- Solutions:**
- (1) Copy a few white paper documents.
  - (2) If the marks are at intervals of approx. 50mm (1.96"), clean the transfer charging roller, but if they are at intervals of approx. 63mm (2.48"), clean the pressure roller.
  - (3) Clean the paper feed guide and fixing entrance guide.
  - (4) Replace the transfer charging roller.
  - (5) Replace the pressure roller.

**• Black vertical lines**

---

- Solutions:**
- (1) Open the front cover during printing, and remove the toner cartridge. Open the cartridge drum cover shutter manually, and check whether there are black vertical lines on the photosensitive drum. If there are black lines, replace the toner cartridge. If not, go the following step.
  - (2) Clean the face-down eject roller.
  - (3) Clean the fixing entrance guide.
  - (4) Replace the fixing ass'y.

**• Irregular and smudged black vertical lines**

---

- Solutions:**
- (1) Clean the fixing entrance guide.
  - (2) Replace the toner cartridge.

**• Irregular and smudged black horizontal lines**

---

- Solutions:** If the irregular smudged black lines occur cyclically, replace the toner cartridge. If they are non-cyclical, replace the fixing ass'y.

**• Marks**

---

- Solutions:**
- (1) If the marks are at intervals of approx. 50mm (1.96"), clean the transfer charging roller; if they are at intervals of approx. 75mm (2.95"), clean the fixing ass'y; and if they are at intervals of approx. 75mm (2.95"), or 38mm (1.5"), replace the toner cartridge.
  - (2) Clean the paper feed guide.
  - (3) Clean the fixing entrance guide.

**• Blank spots**

---

- Solutions:**
- (1) Clean the transfer charging roller.
  - (2) Replace the transfer charging roller.
  - (3) Replace the toner cartridge.
  - (4) Check for foreign matter between the transfer charging roller gear and the drive gear.
  - (5) Clean the developing bias contact and the toner cartridge contact.
  - (6) Replace the PCNT board.
  - (7) Replace the power supply unit.
  - (8) Replace the SCNT board.



**• White vertical lines**

---

- Solutions:**
- (1) Remove the toner cartridge and shake it lightly five or six times.
  - (2) Open the toner cartridge drum shutter and if there are vertical white lines on the photosensitive drum, replace the toner cartridge.
  - (3) Check for foreign matter stuck in the LASER output hole on the LASER/scanner section or the LASER input hole on the toner cartridge.
  - (4) Clean the face-up eject roller.
  - (5) Clean the fixing entrance guide.
  - (6) Replace the fixing ass'y.
  - (7) Replace the LASER/scanner section.

**• White horizontal lines**

---

- Solutions:**
- (1) Replace the toner cartridge.
  - (2) Replace the fixing ass'y.

**• Faulty registration**

---

- Solutions:**
- (1) Check if more than the regulation amount of paper is loaded in the sheet feeder.
  - (2) Clean the paper pickup roller.
  - (3) Replace the paper pickup roller.
  - (4) Check whether the paper edge sensor actuator is damaged or deformed.
  - (5) Replace the pickup solenoid.
  - (6) Replace the paper edge sensor.
  - (7) Replace the SCNT board.

**• Distortion/BD signal failure**

---

- Solutions:**
- (1) Check the connection between the LASER/scanner section and PCNT board (J203) connector connections.
  - (2) Replace the LASER/scanner section.
  - (3) Replace the PCNT board.

**• Partially compressed/stretched image**

---

- Solutions:**
- (1) Check for foreign matter between the toner cartridge gear and the drive gear.
  - (2) Check if the toner cartridge gear is broken.
  - (3) Replace the toner cartridge.

**• Poor fixing**

---

- Solutions:**
- (1) If the marks are at intervals of approx. 75mm (2.95"), clean the fixing ass'y; if they are at intervals of approx. 63mm (2.48"), clean the pressure roller.
  - (2) Replace the fixing ass'y.
  - (3) Replace the pressure roller.
  - (4) See the next page, and check the nip width of the fixing section. If it is not as specified, replace the fixing pressure plate.

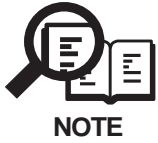

**Checking the fixing nip width**

Improperly set fixing nip may cause a fixing ass’y problem. The fixing ass’y is not designed to allow adjustment of the nip.

Check the fixing ass’y nip by using the following procedure.

- (1) Either take along one or two all-black copies of A4 or letter size made with a copier, or make one using a copier at the customer site.
- (2) Set the black copy in the sheet feeder with the black side facing up.
- (3) Change the paper delivery selector to the face-up delivery slot.
- (4) Enter the test mode and run [3] PRINT, [6] ENDURANCE.
- (5) Turn the power off when the beginning of the paper appears in the face-up delivery slot. Turn the power off, wait for 10 seconds, and remove the paper from the face-up delivery slot slowly.
- (6) Measure the widths of the areas on the paper where toner luster is visible and check whether they fall within the range shown in below table.

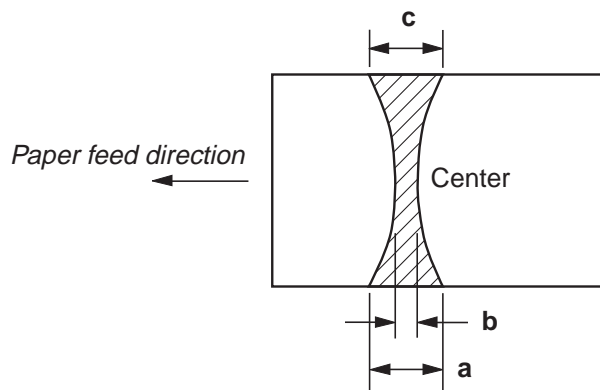

	Dimension
b	3.0 to 5.0 mm (0.12" to 0.20")
a - c	0.5 mm (0.02") or less
a - b	1.0. mm (0.04") or less
b - c	1.0. mm (0.04") or less

**Figure 3-6 Fixing Nip Width**

### 4.3.3 Scanning problems

- **Faulty scanning (Evaluation criteria: Test print is good, but the copied image is poor.)**
- **The document is not fed.**

**The document feed motor does not run. (Evaluation criteria: Check it visually.)**

- (1) Check the connection between the document feed motor and the PCNT board (J401).
- (2) Check the document feed motor's resistance. 5.6 ~ 6.8  $\Omega$ /1 phase is normal. (Fig. 3-7)
- (3) Replace the document feed motor.
- (4) Replace the PCNT board.
- (5) Replace the SCNT board.

**The document slips against the rollers. (Evaluation criteria: Check it visually. Stretched copy image.)**

- (1) See *page 3-4* and clean the document reading section.
- (2) Replace the reading section's rollers.

**The document does not separate. (Evaluation criteria: Check it visually.)**

- (1) Check whether the document feed motor is driving all the rollers. (Check for any damaged gears or foreign matter stuck inside.)
- (2) Check whether the document feed lever is set to manual document feed.
- (3) See *page 3-4* and clean the separation roller and separation guide.
- (4) Replace the separation roller and separation guide.

**The scanner unit's sensors are defective (Evaluation criteria: The placed document or transported document is not detected.)**

- (1) Check for any faulty sensors while executing the copying operation and test mode.
- (2) Check the connection between the operation panel unit and the SCNT board (J7).
- (3) Replace operation panel unit.
- (4) Replace the SCNT board.

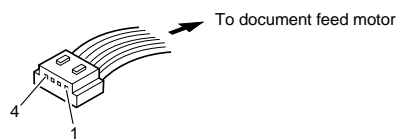

Document feed motor connector

1-2 : 5.6~6.8 $\Omega$   
 3-4 : 5.6~6.8 $\Omega$

**Figure 3-7 Document Feed Motor Connector**

- **The reading image is abnormal. (Evaluation criteria: Check the copy image's faults.)**

**Nothing is printed.**

---

- (1) Check the connection between the contact sensor and SCNT board (J6).
- (2) Replace the contact sensor unit.
- (3) Replace the SCNT board.

**The image has vertical stripes.**

---

- (1) Clean the contact sensor's scanning glass.
- (2) Check the connection between the contact sensor and SCNT board (J6).
- (3) Replace the contact sensor unit.

**The image has thick vertical stripes.**

---

- (1) Clean the contact sensor's scanning glass.
- (2) Check the connection between the contact sensor and SCNT board (J6).
- (3) Replace the contact sensor unit.

#### **4.3.4 Communication problems**

- **D-channel connection error (Service error code “##1001~##1131”)**

- (1) Set #4B ISDN BASIC Bitswitch SW03 bit2 to “1”.
- (2) Set #4B ISDN BASIC Bitswitch SW03 bit4 to “1”.
- (3) Set #4B ISDN BASIC Bitswitch SW03 bit5 to “0”.
- (4) Set #4B ISDN BASIC Bitswitch SW08 bit2 to “0”.
- (5) Set #4B ISDN BASIC Bitswitch SW01 bit4 to “1” and #4B ISDN BASIC Numeric No.19 to “3”.
- (6) Set #4B ISDN BASIC Bitswitch SW06 bit0 to “1”.

- **Cannot perform G4 communication (After a G4 call, fall back to G3. Communication will complete normally.)**

- (1) Confirm whether or not the receiving side is using G4FAX.
- (2) Set #4B ISDN BASIC Bitswitch SW03 bit2 to “1”.
- (3) Set #4B ISDN BASIC Bitswitch SW03 bit4 to “1”.

- **Cannot receive**

- (1) When SYSTEM SETTINGS “CHECK RX ID” is set to “ON”, confirm whether the telephone number in the USER SETTINGS “ENTER ISDN NO.” contract is registered or not.
- (2) When the machine is included in the same bus, and multiple terminals are connected, make sure that the telephone number in the USER SETTINGS “ENTER ISDN NO.” contract is not duplicated in other terminals.
- (3) When SYSTEM SETTINGS “RX RESTRICTION” is set to “ON”, register the telephone number of the one-touch dial or coded dial contract.

## **5. SERVICE SWITCHES**

### **5.1 Hardware Switches**

None.

## **5.2 Service Data Settings**

Service data can be checked and changed with items on display menus. The default values of the SSSW/parameters available in this fax machine are shown in *this Chapter, 5.2.3 Service data settings* in this manual. The SSSW/parameters given in the previous product-specific manual are explained in the *G3 Facsimile Service Data Handbook*. The new switches for this model are described in *this Chapter, 5.2.5 New SSSWs/parameters added to this model*.

### **5.2.1 Service data overview**

The service data menu items are divided into the following ten blocks.

#### **#1 SSSW (Service Soft Switch settings)**

These setting items are for basic fax service functions such as error management, echo countermeasures, and communication trouble countermeasures.

#### **#2 MENU (MENU switch settings)**

These setting items are for functions required during installation, such as NL equalizer and transmission levels.

#### **#3 NUMERIC Param. (NUMERIC parameter settings)**

These setting items are for inputting numeric parameters such as the various conditions for the FAX/TEL switching function.

#### **#4A SPECIAL (SPECIAL switch settings)**

These setting items are for special functions.

#### **#4B ISDN (ISDN settings)**

These settings items are for the purpose of controlling the D-channel protocol and the B-channel protocol.

#### **#5 TYPE (TYPE setting)**

The type setting makes the service data conform to a specific nation's communications standards.

#### **#6 GENESIS (UHQ function setting)**

These setting items are for scanned image processing functions such as edge enhancement and error diffusion processing.

#### **#7 PRINTER (PRINTER function settings)**

These setting items are for basic printer service functions such as the reception picture reduction conditions. Also there is an item for resetting the printer section without switching the power off-on.

#### **#8 CLEAR (data initialization mode)**

Various data are initialized by selecting one of these setting items. There is a setting item for checking/inputting the total number of pages printed and total number of pages scanned by this fax.

#### **#9 ROM (ROM management)**

ROM data such as the version number and checksum are displayed.

#### **#10 REPORT (Service report output function)**

The service report can be output in three types of forms.

### 5.2.2 Service data registration/setting method

Service data can be registered and set by the following operations:

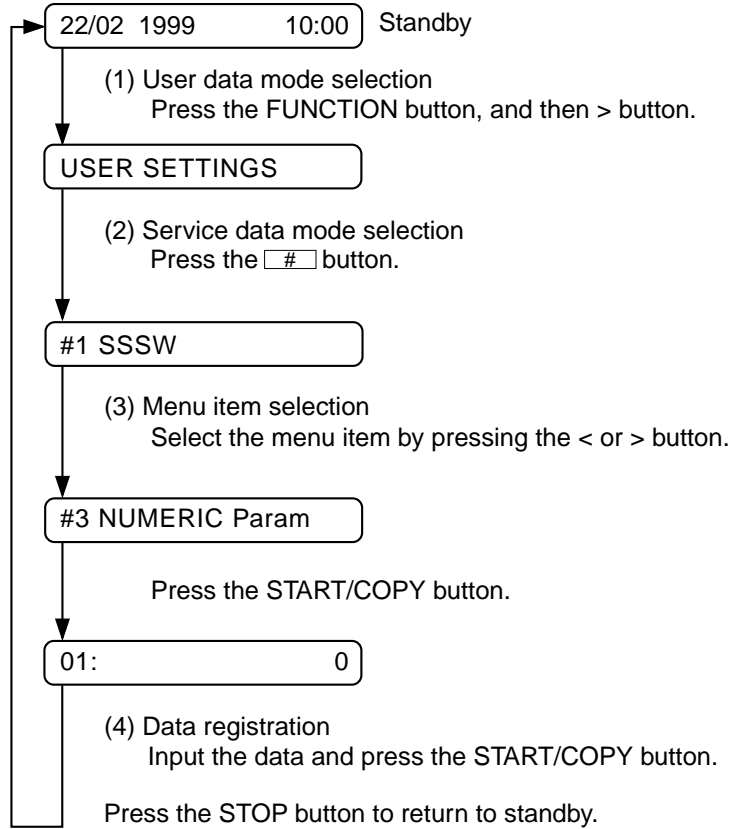

Figure 3-8 Service Data Setting Method



When using service mode, detach the ISDN line from the main unit. Proper reception cannot be guaranteed when using service mode.

### 5.2.3 Service data settings

The flowchart shows the default values for Europe.  
For other type default, see page 3-79~3-89.

**Service data**

10 ◀ ↔ ▶ 12

Bit	7	6	5	4	3	2	1	0	
#1 SSSW (Service soft switch setting)									
SW01	0	-	-	1	0	0	0	0	Error management
SW02	-	-	-	-	-	-	-	1	Memory clear list output setting
SW03	0	0	0	0	-	-	0	-	Echo solution setting
SW04	0	0	-	0	0	0	-	-	Communication trouble solution settings
SW05	-	-	-	0	-	0	0	-	Standard function (DIS signal) setting
SW06	0	-	0	0	-	0	0	0	Scan condition settings
SW07	0	0	-	-	-	-	-	-	Closed network function settings
SW08	0	0	0	0	0	0	0	0	Closed network ID settings
SW09	-	-	-	-	-	1	0	0	Communications result display
SW10	-	-	-	-	-	-	-	-	function settings
SW11	-	-	-	-	-	-	-	-	Not used
SW12	0	-	1	1	1	0	1	0	Not used
SW13	-	-	-	-	-	-	-	-	Page timer settings
SW14	-	-	-	-	-	-	-	-	Not used
SW15	-	-	-	-	-	-	-	-	Not used
SW16	-	-	-	-	-	-	-	-	Not used
SW17	-	-	-	-	-	-	-	-	Not used
SW18	-	-	-	-	-	-	-	-	Not used
SW19	-	-	-	-	-	-	-	-	Not used
SW20	-	-	-	-	-	-	-	-	Not used
SW21	-	-	-	-	-	-	-	-	Not used
SW22	-	-	-	-	-	-	-	-	Not used
SW23	-	-	-	-	-	-	-	-	Not used
SW24	-	-	-	-	-	-	-	-	Copy function settings
SW25	-	-	-	-	-	-	0	0	Not used
SW26	0	0	-	-	-	-	-	0	Not used
SW27	-	-	-	-	-	-	-	-	Not used
SW28	-	-	-	-	-	-	-	-	Not used
SW29	-	-	-	-	-	-	-	-	Report display function settings
SW30	-	-	-	-	-	-	-	-	

\*  
↑  
↓  
#

Figure 3-9 Service Data (page 1)



The switches marked “-” are not used. Do not change their settings.



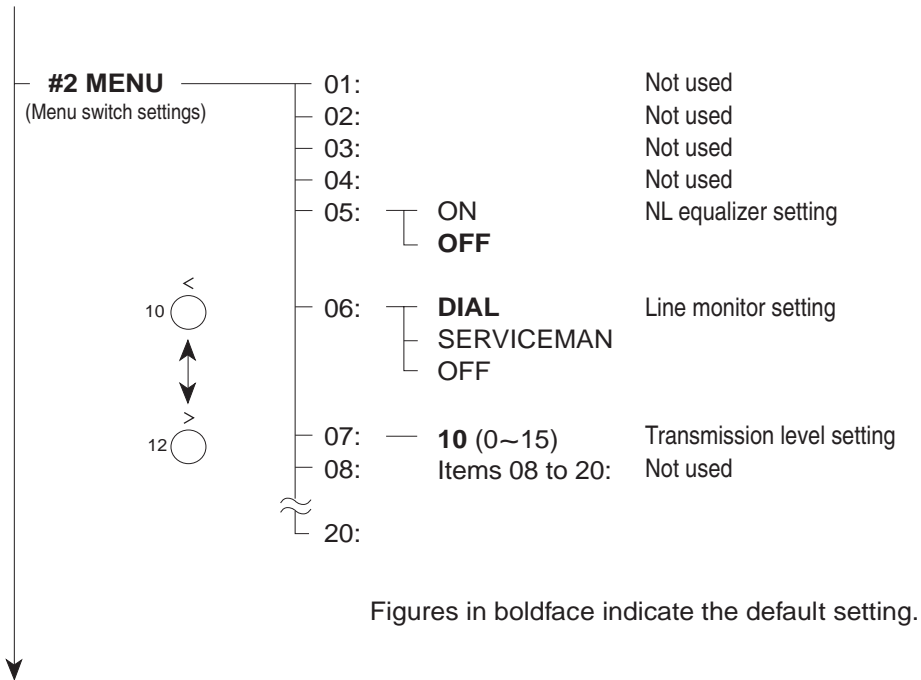

Figure 3-10 Service Data (page 2)



No. 01 to 04, 08 to 20 are not used. Do not change their settings.

#3 NUMERIC Param. (Numeric parameter settings)			
	Default	Range	
01:	–		Not used
02:	10 (10%)	(1~99)	RTN signal transmission condition (1)
03:	15 (15 lines)	(2~99)	RTN signal transmission condition (2)
04:	12 (12 times)	(1~99)	RTN signal transmission condition (3)
05:	–		Not used
06:	–		Not used
07:	–		Not used
08:	–		Not used
09:	6 (6 digits)	(1~20)	The number of digits in telephone number compared against TSI signal to be matched for restricted receiving function
10:	5500 (55 seconds)	(0~9999)	Line connection detection time (T0 timer)
11:	3500 (35 seconds)	(0~9999)	T1 timer (Rx)
12:	5800 (5800 lines)	(0~65535)	Not used
13:	1300 (13 seconds)	(0~9999)	Maximum time to receive oneline of image data
14:	Item 14 to 30 :		Not used
30:			

Figure 3-11 Service Data (page 3)



No. 01, 05 to 08, 12 and 14 to 30 are not used. Do not change their settings.



**NOTE**

**Regarding the T0 timer (SSSW #3 NUMERIC Param. No. 10)**

When the country type (SSSW #5 TYPE) is set to “FRANCE,” the default value of SSSW#3 NUMERIC Param. No.10 is “4000,” but the actual T0 timer is 140 seconds. However, when this default value is changed, the settable range of the T0 timer becomes 0-99.99 seconds. For example, if the SSSW #3 NUMERIC Param. No.10 is set to “5000,” the T0 timer is 50 seconds. In addition, after changing the default value, even if the “4000” is reset, the T0 timer will be no 140 seconds, but 40 seconds. To return the T0 timer to 140 seconds, set the SSSW #5 TYPE to “FRANCE.”

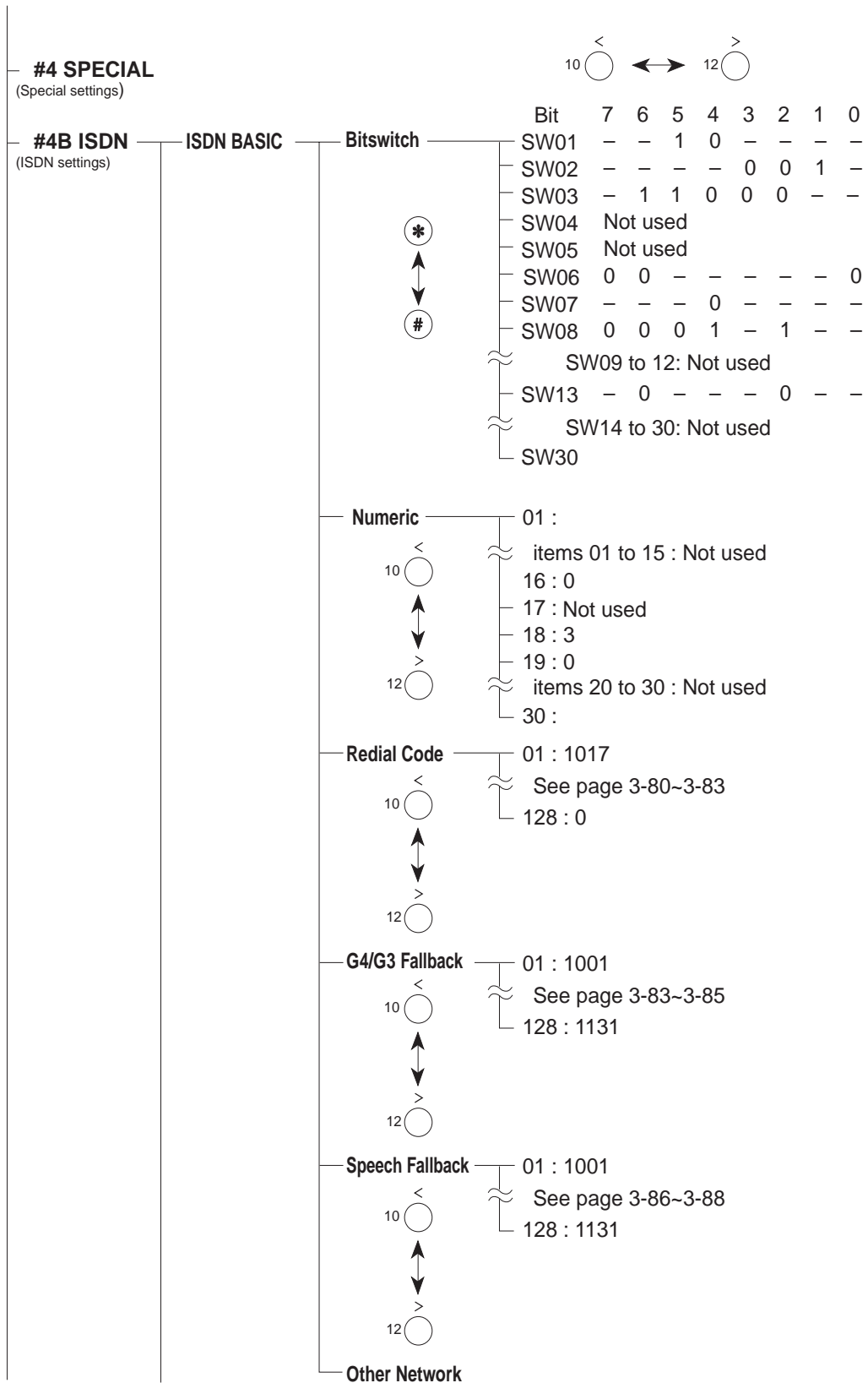

Figure 3-12 Service Data (page 4)

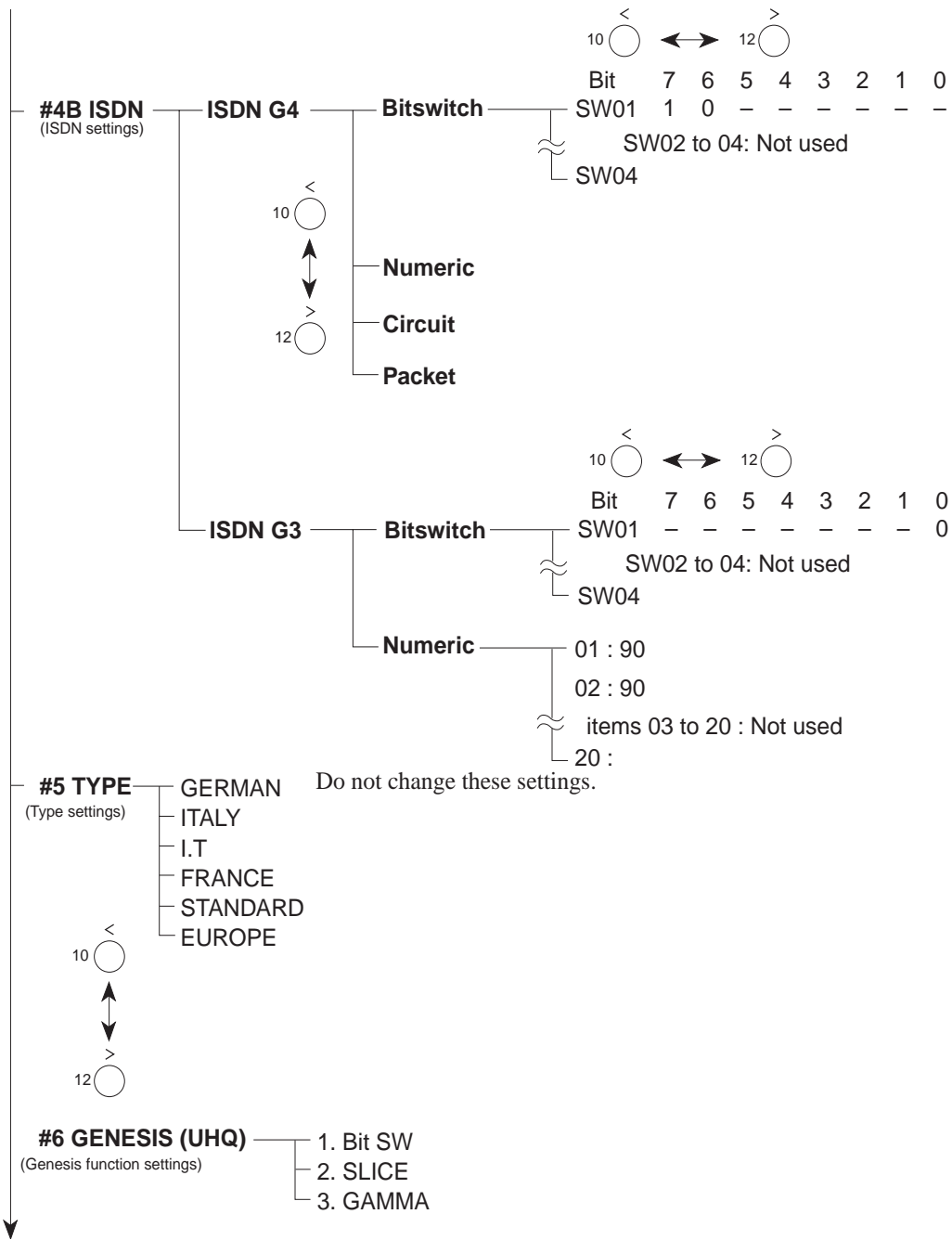

Figure 3-13 Service Data (page 5)



**#4A SPECIAL (Special settings)**

The values of these items are all set to match a specific nation's communications standards by the #5 TYPE setting. Do not change these settings.

**#6 GENESIS (UHQ function settings)**

Tampering with this setting may cause the scanned image quality to deteriorate. Do not change these settings.

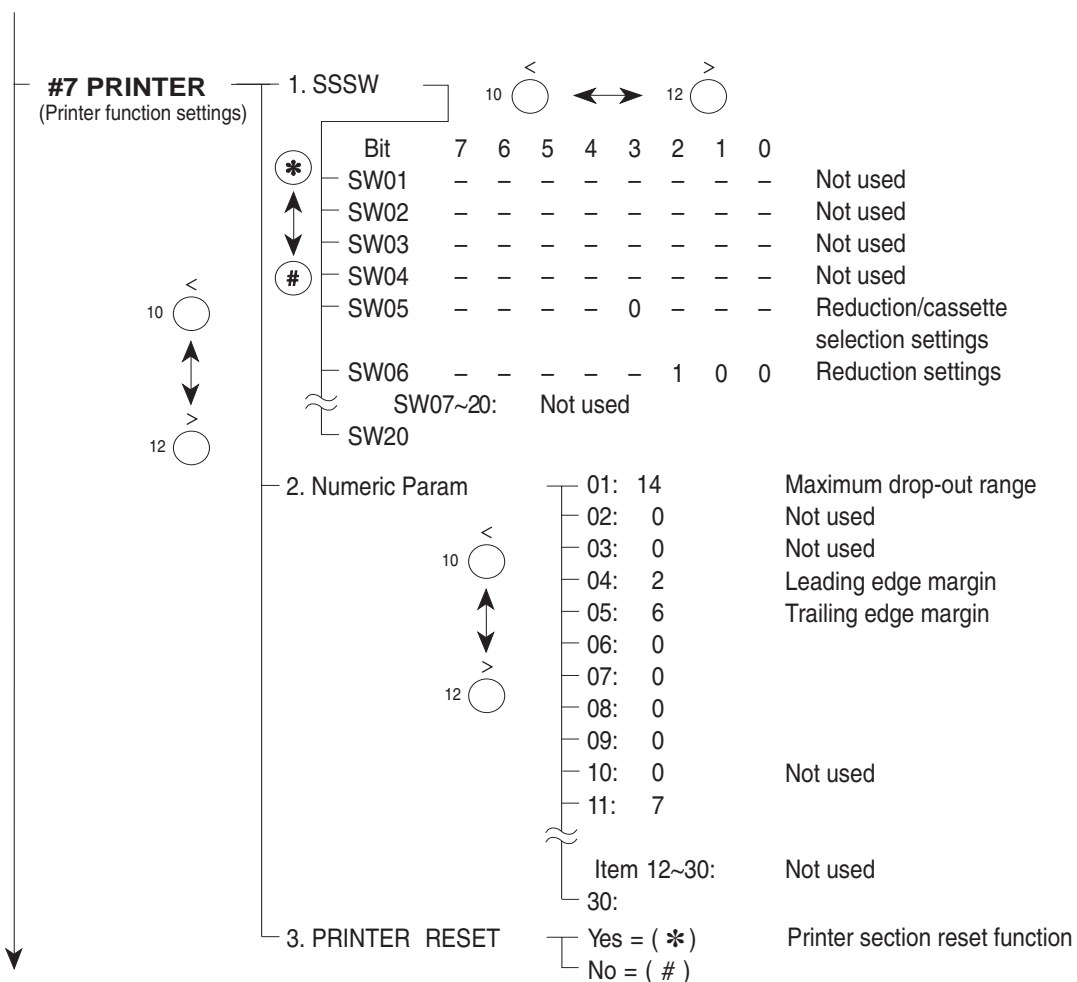

Figure 3-14 Service Data (page 6)

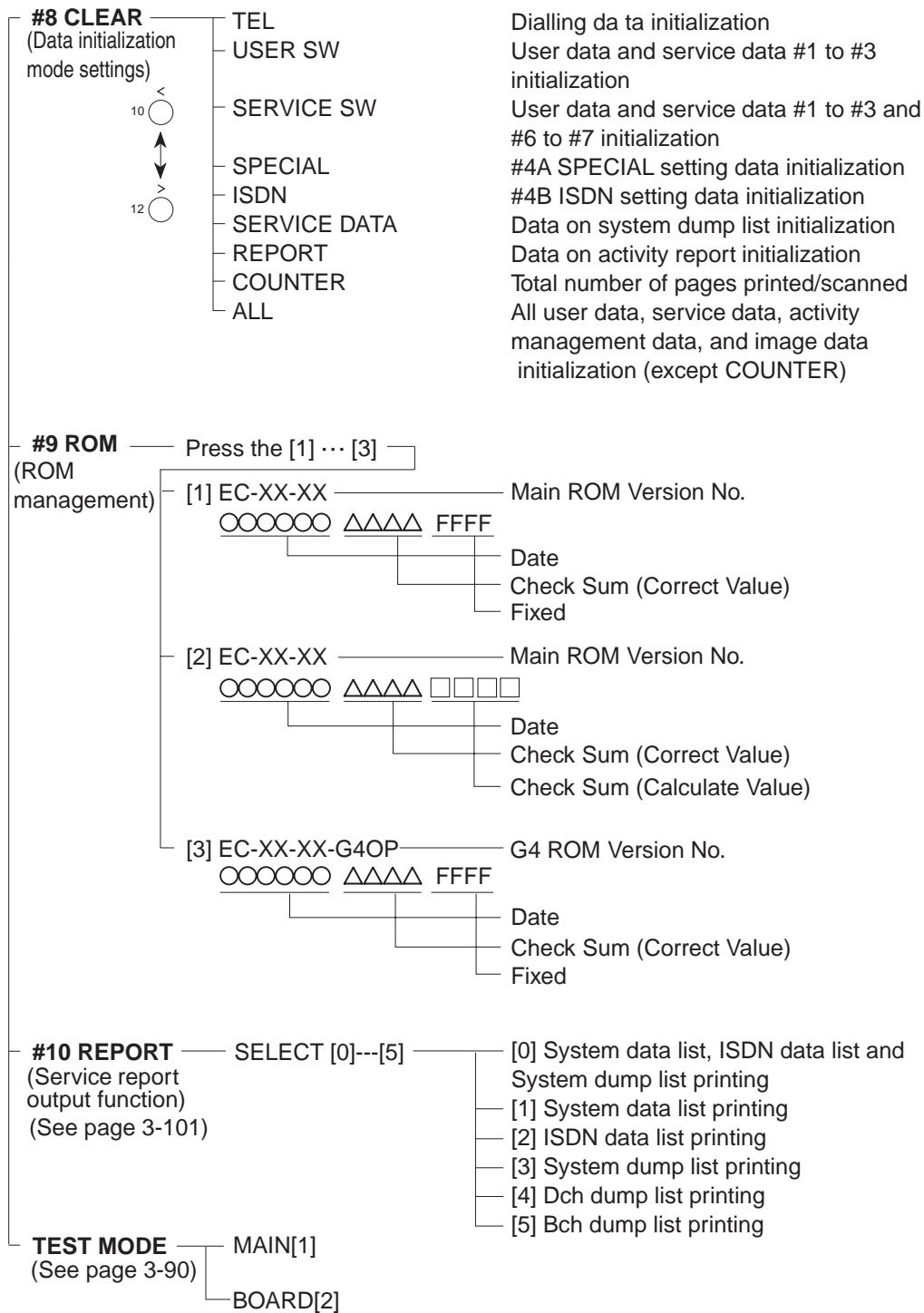

Figure 3-15 Service Data (page 7)



For details on test mode, see 6.1 Service Test Functions on page 3-90.

REFERENCE

**This page intentionally left blank**

### 5.2.4 Explanation of service data

#### a) SSSW (Service Soft Switch settings)

The items registered and set by each of these switches comprise 8-bit switches. The figure below shows which numbers are assigned to which bits. Each bit has a value of either 0 or 1.

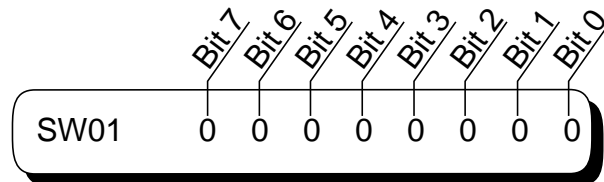

Figure 3-16 Bit Switch Display

See the chart in the service data shown in *this Chapter, 5.2.3 Service data settings* to see effective bits and their default values. With the exception of new switches added to this model the meanings (functions) of the bits are not described in this manual except the new switches added to this model. See *the G3 Facsimile Service Data Handbook* (supplied separately) for details of the switches.

Below are examples showing how to read bit switch tables.

Bit	Function	1	0
0	Service error code	Output	<b>Not Output</b>
1	Error dump list	Output	<b>Not Output</b>
2	Not used		
3	Copy function	No	<b>Yes</b>
4	##300 series service error code	Output	<b>Not Output</b>
5	Not used		
6	Date & Time setting restriction	Setting restricted	<b>Setting possible</b>
7	User setting restriction	Setting possible	<b>Setting restricted</b>

Callouts:  
 - A callout pointing to the '1' column: "Indicates that the setting is '1'."  
 - A callout pointing to the '0' column: "Indicates that the setting is '0'."  
 - A callout pointing to the bolded values in the '0' column: "Figures in boldface are default settings."

Figure 3-17 How to Read Bit Switch Tables



**5.2.5 New SSSWs/parameters added to this model**

**#1 SSSW (service soft switch setting)**

**SW01 (service soft switch 01: error management)**

Bit	Function	1	0
0	Service error code	Output	<b>Not output</b>
1	Error dump list	Output	<b>Not output</b>
2	Rx image data transfer	Yes	<b>No</b>
3	Copy function	No	<b>Yes</b>
4 (New)	##300 series service error code	<b>Output</b>	Not output
5	Not used		
6	Date & Time setting restriction	Setting restricted	<b>Setting possible</b>
7	User setting restriction	Setting possible	<b>Setting restricted</b>

**[Bit 4]**

Even when Bit0 is set to “**NOT OUTPUT**”, you can select whether or not to output ##300 series Service Error Codes, caused by hardware malfunction.

When “**OUTPUT**” is selected, ##300 series Service Error Codes are displayed and included in reports.

When “**NOT OUTPUT**” is selected, no Service Error Codes are displayed.

**#3 NUMERIC PARAM. (numeric parameter settings)**

No.	Function	Selecting range	Default setting
10	T0 Timer	0-9999	5500 (55 sec.)
11	T1 Timer (Rx)	0-9999	3500 (35 sec.)
13	Maximum time to receive one line of image data	500-3000	1300 (13 sec.)

**[No. 10]**

The "wait time after transmission of a dialing signal ends until a significant signal is detected in transmission" was formerly designated as T1 timer with parameter 10.



**NOTE**

The T1 timer for the transmitter (wait time after a significant CED or V21 flag significant signal is detected until the next significant signal is detected) is fixed at 35 seconds.

**[No. 11]**

Set the T1 timer for the receiver (wait time after DIS transmission starts until a significant signal is received.)

If frequent errors occur during reception (2 instances) because of line connection conditions, raise the value of this parameter.

**[No. 13]**

Set the maximum time to receive one line of image data when image data is received.

If the other party is a computer fax and the time to receive one line of image data is long, raise the value of this parameter to increase the maximum reception time.

**#4B ISDN (ISDN settings)**

**ISDN BASIC Bitswitch SW01**

Bit	Function	1	0
0	Not used		
1	Not used		
2	Not used		
3	Not used		
4	Progress Indicator for outgoing Speech calls	Add	<b>Don't Add</b>
5	Progress Indicator for outgoing 3.1kHz-audio calls	<b>Add</b>	Don't Add
6	Not used		
7	Not used		

**[Bit 4]**

For outgoing G3 calls made with Bearer Capability "Speech", the Progress Indicator information element in the SETUP message can be chosen as "Add" or "Don't Add". The "progress description" included in the Progress Indicator information element takes on the same value as that set in #4B ISDN BASIC Numeric Parameter No.19.

In an outgoing G3 call, when an switching equipment exists which cannot receive unless a Progress Indicator information element which includes an appropriate "progress description" is added to the SETUP message, please set this bit to "1".

**[Bit 5]**

For outgoing G3 calls made with Bearer Capability "3.1kHz audio", the Progress Indicator information element in the SETUP message can be chosen as "Add" or "Don't Add." The "progress description" included in the Progress Indicator information element takes on the same value as that set in #4B ISDN BASIC Numeric Parameter No.18.

**ISDN BASIC Bitswitch SW02**

Bit	Function	1	0
0	Not used		
1	Send RELCOMP message when incoming call is rejected	Yes	No
2	G4/G3 automatic fallback	No	Yes
3	Speech fallback	No	Yes
4	Not used		
5	Not used		
6	Not used		
7	Not used		

**[Bit1]**

When the incoming call is impossible because transmission is in progress, sending of the RELCOMP message can be set to either “Yes” or “No.”

**[Bit2]**

For outgoing G4 calls, automatic fallback from G4 to G3 can be set to either “Yes” or “No”. In an outgoing G4 call where this bit is set to “0,” if the network gives notification of a “cause number” which corresponds to an error code set in #4B ISDN BASIC G4/G3 Fallback, an outgoing G3 call will be made after the machine makes one open call.

**[Bit3]**

For outgoing G3 calls, automatic fallback from “3.1kHz audio” to “Speech” can be set to either “Yes” or “No”. In this machine, with a regular outgoing G3 call, the Bearer Capability information element in the SETUP message is set to “3.1kHz audio”. In an outgoing G3 call where this bit is set to “0,” if the network gives notification of a “cause number” which corresponds to an error code set in #4B ISDN BASIC Speech Fallback after the machine makes one open call, the Bearer Capability information element in the SETUP message is set to “Speech,” and an outgoing G3 call is made.

**ISDN BASIC Bitswitch SW03**

Bit	Function	1	0
0	Not used		
1	Not used		
2	Outgoing G4 call HLC	Don't Add	<b>Add</b>
3	Action for incoming G4 when no G4HLC	Incompatible destination	<b>G4 reception</b>
4	Outgoing G4 call LLC	Don't Add	<b>Add</b>
5	Outgoing G3 call LLC	<b>Don't Add</b>	Add
6	Fallback table reference for enforced fallback	<b>Yes</b>	No
7	Not used		

**[Bit2]**

For outgoing G4 calls, the High Layer Compatibility information element in the SETUP message can be set to "Add" or "Don't Add." In an outgoing G4 call, if the High Layer Compatibility information element in the SETUP message is added when an Switching equipment exists which cannot receive, please set this bit to "1."

**[Bit3]**

For incoming G4 calls, when the High Layer Compatibility information element is not added to the SETUP message (Bearer Capability information element "Unrestricted digital" in the SETUP message), the choice can be made to either not receive as "incompatible destination", or to "G4 reception".

**[Bit4]**

For outgoing G4 calls, the Low Layer Compatibility information element in the SETUP message can be set to "Add" or "Don't Add." In an outgoing G4 call, if the Low Layer Compatibility information element in the SETUP message is added when an Switching equipment exists which cannot receive, please set this bit to "1."

**[Bit5]**

For outgoing G3 calls, the Low Layer Compatibility information element in the SETUP message can be set to "Add" or "Don't Add." In an outgoing G3 call, if the Low Layer Compatibility information element in the SETUP message is not added when an Switching equipment exists which cannot receive, please set this bit to "0."

**[Bit6]**

Normally, even with the one condition for operation of enforced G4/G3 fallback, "normal D-channel disconnection," even when a D-channel error occurs with this switch, the choice can be made to enforce or not enforce G4/G3 fallback by selecting "Yes" or "No". If this bit is set to "1," in an outgoing G4 call, even if the network notifies of a "cause number" corresponding to an error code set in #4B ISDN BASIC G4/G3 Fallback, the G4/G3 fallback function is available. However, when #4B ISDN BASIC Bitswitch SW08 bit4 is "0," this function becomes invalid.

**ISDN BASIC Bitswitch SW06**

Bit	Function	1	0
0	Sending Complete information element	Add	Don't Add
1	Not used		
2	Not used		
3	Not used		
4	Not used		
5	Not used		
6	Low Layer Compatibility	Don't Add	Add
7	High Layer Compatibility	Don't Add	Add

**[Bit0]**

For outgoing calls, the Sending Complete information element in the SETUP message can be set to "Add" or "Don't Add." In an outgoing call, if the Sending Complete information element in the SETUP message is not added when an Switching equipment exists which cannot receive, please set this bit to "1." Additionally, only in the case of "ITALY", this bit's default value is "1."

**[Bit6]**

For all outgoing calls, the Low Layer Compatibility information element in the SETUP message can be set to "Add" or "Don't Add." #4B ISDN BASIC Bitswitch SW03 bit4 and bit5 settings will be valid only when this bit is set to "0."

**[Bit7]**

For all outgoing calls, the High Layer Compatibility information element in the SETUP message can be set to "Add" or "Don't Add." #4B ISDN BASIC Bitswitch SW03 bit2 and #4B ISDN BASIC Bitswitch SW08 bit2 settings will be valid only when this bit is set to "0."

**ISDN BASIC Bitswitch SW07**

Bit	Function	1	0
0	Not used		
1	Not used		
2	Not used		
3	Not used		
4	Keep D-channel message log	Don't Save	Save
5	Not used		
6	Not used		
7	Not used		

**[Bit4]**

It is possible to choose to "Save" or "Don't Save" D-channel message logs as D-channel protocol dumps.

**ISDN BASIC Bitswitch SW08**

Bit	Function	1	0
0	Not used		
1	Not used		
2	Outgoing G3 call HLC	<b>Don't Add</b>	Add
3	Not used		
4	G4/G3 enforced fallback	<b>Yes</b>	No
5	Calling Party Number coding change	National Numbering Plan/ISDN	<b>Unknown (TON/NPI)</b>
6	Called Party Number coding change	National Numbering Plan/ISDN	<b>Unknown (TON/NPI)</b>
7	Connected Number coding change	National Numbering Plan/ISDN	<b>Unknown (TON/NPI)</b>

**[[Bit2]**

For outgoing G3 calls, the High Layer Compatibility information element in the SETUP message can be set to "Add" or "Don't Add." In an outgoing G3 call, if the High Layer Compatibility information element in the SETUP message is not added when an Switching equipment exists which cannot receive, please set this bit to "0."

**[Bit4]**

For outgoing G4 calls, if B-channel communication is not completed normally after D-channel connection, it is possible to choose to fallback to G3 and call again or not to do so by selecting "Yes" or "No."

**[Bit5]**

It is possible to choose either "Unknown" or "National Numbering Plan/ISDN" for the coding of the "Type of Number (TON)" in the Calling Party Number information element and that of the "Numbering Plan Identification (NPI)," both of which are included in the SETUP message.

**[Bit6]**

It is possible to choose either "Unknown" or "National Numbering Plan/ISDN" for the coding of the "Type of Number (TON)" in the Called Party Number information element and that of the "Numbering Plan Identification (NPI)," both of which are included in the SETUP message.

**[Bit7]**

It is possible to choose either "Unknown" or "National Numbering Plan/ISDN" for the coding of the "Type of Number (TON)" in the Connected Number information element and that of the "Numbering Plan Identification (NPI)," both of which are included in the CONN message.

**ISDN BASIC Bitswitch SW13**

<b>Bit</b>	<b>Function</b>	<b>1</b>	<b>0</b>
0	Not used		
1	Not used		
2	Bearer Capability of ON-HOOK call	Speech	<b>3.1kHz audio</b>
3	Not used		
4	Not used		
5	Not used		
6	Operations performed after global number incoming call	Don't respond	<b>Respond</b>
7	Not used		

**[Bit2]**

For on-hook outgoing calls, it is possible to choose either “3.1kHz audio” or “Speech” for the Bearer Capability information element included in the SETUP message.

**[Bit6]**

When the SYSTEM SETTINGS “CHECK RX ID” is “ON,” “Respond” or “Don't respond” can be selected with regard to the global number incoming call (no Called Party Number in SETUP message). The main function is only available when the SYSTEM SETTINGS “CHECK RX ID” is “ON.”

**ISDN BASIC Numeric parameter**

<b>No.</b>	<b>Function</b>	<b>Selecting range</b>	<b>Default setting</b>
16	Fallback Wait Time	0-255 (×100msec.)	0 (0msec.)
18	Value of 3.1kHz-audio call-time progress description	0-127	3
19	Value of speech call-time progress description	0-127	0

**[No.16]**

In the case of an outgoing G4 call to G3, or an outgoing G3 Bearer Capability “3.1kHz audio” call which falls back to Bearer Capability “Speech,” it is possible to set the wait time. Specifically, wait time is the interval from when the RELCOMP message is received from the network to when the machine sends the SETUP message. In reality, the time when the switch is set + the interval of approx. 100msec.~200msec. when the machine performs internal processing is wait time.

**[No.18]**

The “progress description” of the Progress Indicator information element which is added to the SETUP message can be designated for 3.1kHz audio outgoing calls.

The only defined values for progress description are 1-5 and 8.

Progress description:

No.1 Calling is not end-to-end ISDN; further call progress information may be available in-band

No.2 Destination address is non ISDN

No.3 Origination address is non ISDN

No.4 Call has returned to the ISDN

No.5 Interworking has occurred and has resulted in a telecommunication service change

No.8 In-band information or an appropriate pattern is now available

**[No.19]**

The “progress description” of the Progress Indicator information element which is added to the SETUP message can be designated for outgoing speech calls.

The only defined values for progress description are 1-5 and 8.

Progress description: As previously mentioned



**This page intentionally left blank**

**ISDN BASIC Redial Code**

No.	Function	Selecting range	Default setting
01-128	Redial	1001-1131	See page 3-80~3-83

**ISDN BASIC G4/G3 Fallback**

No.	Function	Selecting range	Default setting
01-128	G4/G3 fallback	1001-1131	See page 3-83~3-85

**ISDN BASIC Speech Fallback**

No.	Function	Selecting range	Default setting
01-128	Speech fallback	1001-1131	See page 3-86~3-88

**[Redial]**

If a D-channel protocol error occurs with an outgoing call, the 4-digit error code displayed on the LCD of the machine's this switch or on the report can be registered so that, from the next outgoing call onwards, if the same error occurs, the machine will redial.

**[G4/G3 Fallback]**

If a D-channel protocol error occurs with an outgoing G4 call, the 4-digit error code displayed on the LCD of the machine's switch or on the report can be registered so that, from the next outgoing call onwards, if the same error occurs, the machine will make an outgoing G3 call after making one public call.

**[Speech Fallback]**

If a D-channel protocol error occurs with an outgoing G3 call with Bearer Capability "3.1kHz audio," the 4-digit error code displayed on the LCD of the machine's switch or on the report can be registered so that, from the next outgoing call onwards, if the same error occurs, the machine will make an outgoing G3 call with Bearer Capability "speech" after making one public call.



**NOTE**

The error codes registered in #4B ISDN BASIC "Redial Code," "G4/G3 Fallback," and "Speech Fallback" can contain a maximum of 128 characters each.



Please do not clear or otherwise change the value registered in #4B ISDN BASIC "Redial Code," "G4/G3 Fallback," and "Speech Fallback." It is feared that trouble with communication will occur.

**Example) G4/G3 Fallback function and operation procedure**

- In the case where the FAX-L260i makes an outgoing G4 call to a G3 machine
  - After the FAX-L260i sends the SETUP message which includes the Bearer Capability information element “unrestricted digital,” notification of a DISC message containing Cause number “88” is made from the network, and a D-channel connection error occurs. Cause number “88” means “Incompatible Destination,” and the FAX-L260i displays the service error code “##1088.” The "cause number" is set to the clearing message first notified by the network (DISC message, REL message, or RELCOMP message).

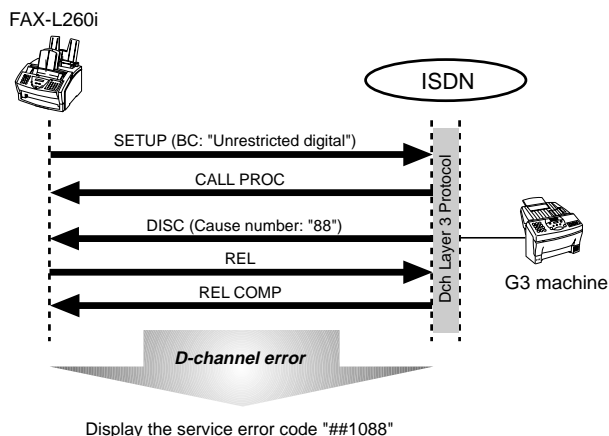

**Figure 3-18 G4 -> G3 Fallback Procedure (1)**

- Next, the 4 digits “1088” of the service error code “##1088” are registered in service data #4B ISDN BASIC G4/G3 Fallback, and another outgoing call is made to the G4. In this situation, with the first outgoing call, a) D-channel cannot be connected in the same way, but after receiving the RELCOMP message from the network, the Bearer Capability information element included in the SETUP message is changed from “unrestricted digital” to “3.1kHz audio” and the SETUP message is sent again.

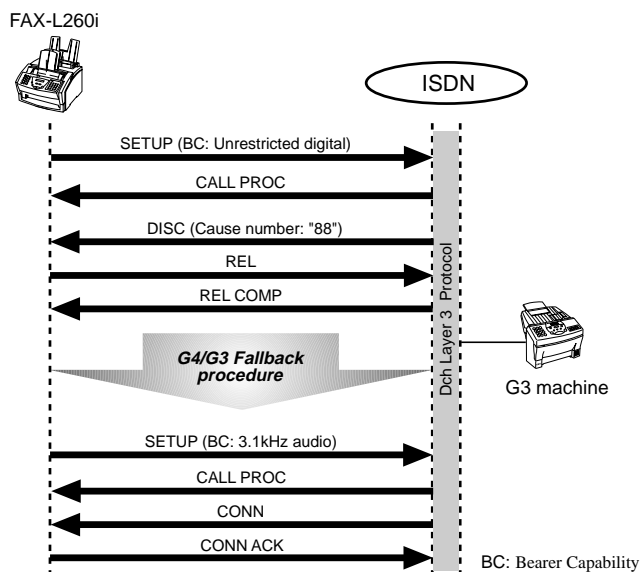

**Figure 3-19 G4 -> G3 Fallback Procedure (2)**

**ISDN G4 Bitswitch SW01**

<b>Bit</b>	<b>Function</b>	<b>1</b>	<b>0</b>
0	Not used		
1	Not used		
2	Not used		
3	Not used		
4	Not used		
5	Not used		
6	G4 B-channel Log Mode	All Communications	<b>Only Error Communications</b>
7	G4 B-channel communication log	<b>Prohibited</b>	permitted

**[Bit6]**

It is possible to choose whether the G4 B-channel communications log will gather “Only Error Communications” or “All Communications.”

**[Bit7]**

It is possible to choose whether the G4 B-channel communications logging and output will be “Permitted” or “Prohibited.”

**ISDN G3 Bitswitch SW01**

Bit	Function	1	0
0	Enforced G3 calling	Yes	No
1	Not used		
2	Not used		
3	Not used		
4	Not used		
5	Not used		
6	Not used		
7	Not used		

**[Bit0]**

When the main bit is "0," the outgoing call is made with the designated mode, but when the main bit is "1," it is made with G3 mode as default. For example, even in cases where the outgoing call is made with one-touch dial and coded dial designated by TX mode "G4," the call will be made with G3 mode.

**ISDN G3 Numeric parameter**

No.	Function	Selecting range	Default settings
01	Length of outgoing DTMF signal	10-9999	90 (90msec.)
02	Length of minimum pause for outgoing DTMF signal	10-9999	90 (90msec.)

**[No.01]**

It is possible vary the transmission time of the DTMF signal transmission.

**[No.02]**

It is possible to vary the minimum pause time of the DTMF signal transmission.

**This page intentionally left blank**

**SSSW Default Setting**

TYPE	EUROPE	GERMAN	ITALY	FRANCE
<b>#1 SSSW</b>				
SW01	00010000	00010000	00010000	00010000
SW02	00000001	00000001	00000001	00000001
SW03	00000000	00000000	00000000	00000000
SW04	00000000	00000010	00000010	00000000
SW05	00000000	00000000	00000000	00000000
SW06	00000000	00000000	00000000	00000000
SW07	00000000	00000000	00000000	00000000
SW08	00000000	00000000	00000000	00000000
SW09	00000100	00000100	00000100	00000100
SW10	00000000	00000000	00000000	00000000
SW11	00000000	00000000	00000000	00000000
SW12	00111010	10111010	00111010	00111010
SW13	00000000	00000000	00000000	00000000
SW14	00000000	00000000	00000000	00000000
SW15	00000000	00000000	00000000	00000000
SW16	00000000	00000000	00000000	00000000
SW17	00000010	00000010	00000010	00000000
SW18	00000000	00000000	00000000	00000000
SW19	01001000	01001000	01001000	01001000
SW20	01000000	01000000	01000000	01000000
SW21	00000000	00000000	00000000	00000000
SW22	00000000	00000000	00000000	00000000
SW23	00000000	00000000	00000000	00000000
SW24	00000000	00000000	00000000	00000000
SW25	00001000	00001001	00001000	00001000
SW26	00000000	00000000	00000000	00000000
SW27	00000000	00000000	00000000	00000000
SW28	00000000	00000000	00000000	00000000
SW29	00000000	00000000	00000000	00000000
SW30	00000000	00000000	00000000	00000000
<b>#2 MENU</b>				
05:	OFF	OFF	OFF	OFF
06:	DIAL	DIAL	DIAL	DIAL
07:	10	10	10	10
<b>#3 MUMERIC Param.</b>				
02:	10	8	10	10
03:	15	15	15	15
04:	12	6	12	12
09:	6	6	6	6
10:	5500	6000	5500	4000
11:	3500	3500	3500	3500
12:	5800	5800	5800	5800
13:	1300	1300	1300	1300

**SSSW Default Setting**

TYPE	EUROPE	GERMAN	ITALY	FRANCE
<b>#4B ISDN ISDN BASIC Bitswitch</b>				
SW01	00100000	00100000	00100000	00100000
SW02	01100011	01100011	01100011	01100011
SW03	01100000	01100000	11100000	01100000
SW06	00000010	00000010	00000011	00000011
SW07	00001100	00001100	00001100	00001100
SW08	00011100	00010100	00011100	00011100
SW13	00001000	00001000	00001000	00001000
<b>NUMERIC Param.</b>				
16:	0	0	0	20
18:	3	3	3	3
19:	0	0	0	0
<b>Redial Code</b>				
01:	1017	1017	1017	1017
02:	1018	1018	1018	1018
03:	1019	1019	1019	1019
04:	1027	1027	1027	1027
05:	1031	1031	1031	1031
06:	1034	1034	1034	1034
07:	1041	1041	1041	1041
08:	1042	1042	1042	1042
09:	1044	1044	1044	1044
10:	1049	1049	1049	1049
11:	1127	1127	1127	1127
12:	1131	1131	1131	1131
13:	1016	1016	1016	1016
14:	0	0	0	0
15:	0	0	0	0
16:	0	0	0	0
17:	0	0	0	0
18:	0	0	0	0
19:	0	0	0	0
20:	0	0	0	0
21:	0	0	0	0
22:	0	0	0	0
23:	0	0	0	0
24:	0	6	0	0
25:	0	0	0	0



**SSSW Default Setting**

TYPE	EUROPE	GERMAN	ITALY	FRANCE
26:	0	0	0	0
27:	0	0	0	0
28:	0	0	0	0
29:	0	0	0	0
30:	0	0	0	0
31:	0	0	0	0
32:	0	0	0	0
33:	0	0	0	0
34:	0	0	0	0
35:	0	0	0	0
36:	0	0	0	0
37:	0	0	0	0
38:	0	0	0	0
39:	0	0	0	0
40:	0	0	0	0
41:	0	0	0	0
42:	0	0	0	0
43:	0	0	0	0
44:	0	0	0	0
45:	0	0	0	0
46:	0	0	0	0
47:	0	0	0	0
48:	0	0	0	0
49:	0	0	0	0
50:	0	0	0	0
51:	0	0	0	0
52:	0	0	0	0
53:	0	0	0	0
54:	0	0	0	0
55:	0	0	0	0
56:	0	0	0	0
57:	0	0	0	0
58:	0	0	0	0
59:	0	0	0	0
60:	0	0	0	0
61:	0	0	0	0
62:	0	0	0	0
63:	0	0	0	0
64:	0	0	0	0
65:	0	0	0	0
66:	0	0	0	0
67:	0	0	0	0
68:	0	0	0	0
69:	0	0	0	0
70:	0	0	0	0
71:	0	0	0	0
72:	0	0	0	0

**SSSW Default Setting**

TYPE	EUROPE	GERMAN	ITALY	FRANCE
73:	0	0	0	0
74:	0	0	0	0
75:	0	0	0	0
76:	0	0	0	0
77:	0	0	0	0
78:	0	0	0	0
79:	0	0	0	0
80:	0	0	0	0
81:	0	0	0	0
82:	0	0	0	0
83:	0	0	0	0
84:	0	0	0	0
85:	0	0	0	0
86:	0	0	0	0
87:	0	0	0	0
88:	0	0	0	0
89:	0	0	0	0
90:	0	0	0	0
91:	0	0	0	0
92:	0	0	0	0
93:	0	0	0	0
94:	0	0	0	0
95:	0	0	0	0
96:	0	0	0	0
97:	0	0	0	0
98:	0	0	0	0
99:	0	0	0	0
100:	0	0	0	0
101:	0	0	0	0
102:	0	0	0	0
103:	0	0	0	0
104:	0	0	0	0
105:	0	0	0	0
106:	0	0	0	0
107:	0	0	0	0
108:	0	0	0	0
109:	0	0	0	0
110:	0	0	0	0
111:	0	0	0	0
112:	0	0	0	0
113:	0	0	0	0
114:	0	0	0	0
115:	0	0	0	0
116:	0	0	0	0
117:	0	0	0	0
118:	0	0	0	0
119:	0	0	0	0

**SSSW Default Setting**

TYPE	EUROPE	GERMAN	ITALY	FRANCE
120:	0	0	0	0
121:	0	0	0	0
122:	0	0	0	0
123:	0	0	0	0
124:	0	0	0	0
125:	0	0	0	0
126:	0	0	0	0
127:	0	0	0	0
128:	0	0	0	0
<b>G4/G3 Fallback</b>				
01:	1001	1001	1001	1001
02:	1002	1002	1002	1002
03:	1003	1003	1003	1003
04:	1004	1004	1004	1004
05:	1005	1005	1005	1005
06:	1006	1006	1006	1006
07:	1007	1007	1007	1007
08:	1008	1008	1008	1008
09:	1009	1009	1009	1009
10:	1010	1010	1010	1010
11:	1011	1011	1011	1011
12:	1012	1012	1012	1012
13:	1013	1013	1013	1013
14:	1014	1014	1014	1014
15:	1015	1015	1015	1015
16:	0	0	0	0
17:	0	0	0	0
18:	1018	1018	1018	1018
19:	1019	1019	1019	1019
20:	1020	1020	1020	1020
21:	1021	1021	1021	1021
22:	1022	1022	1022	1022
23:	1023	1023	1023	1023
24:	1024	1024	1024	1024
25:	1025	1025	1025	1025
26:	1026	1026	1026	1026
27:	1027	1027	1027	1027
28:	1028	1028	1028	1028
29:	1029	1029	1029	1029
30:	1030	1030	1030	1030
31:	1031	1031	1031	1031
32:	1032	1032	1032	1032
33:	1033	1033	1033	1033
34:	0	0	0	0
35:	1035	1035	1035	1035

**SSSW Default Setting**

TYPE	EUROPE	GERMAN	ITALY	FRANCE
36:	1036	1036	1036	1036
37:	1037	1037	1037	1037
38:	1038	1038	1038	1038
39:	1039	1039	1039	1039
40:	1040	1040	1040	1040
41:	1041	1041	1041	1041
42:	0	0	0	1042
43:	1043	1043	1043	1043
44:	1044	1044	1044	1044
45:	1045	1045	1045	1045
46:	1046	1046	1046	1046
47:	1047	1047	1047	1047
48:	1048	1048	1048	1048
49:	1049	1049	1049	1049
50:	1050	1050	1050	1050
51:	1051	1051	1051	1051
52:	1052	1052	1052	1052
53:	1053	1053	1053	1053
54:	1054	1054	1054	1054
55:	1055	1055	1055	1055
56:	1056	1056	1056	1056
57:	1057	1057	1057	1057
58:	1058	1058	1058	1058
59:	1059	1059	1059	1059
60:	1060	1060	1060	1060
61:	1061	1061	1061	1061
62:	1062	1062	1062	1062
63:	1063	1063	1063	1063
64:	1064	1064	1064	1064
65:	1065	1065	1065	1065
66:	1066	1066	1066	1066
67:	1067	1067	1067	1067
68:	1068	1068	1068	1068
69:	1069	1069	1069	1069
70:	1070	1070	1070	1070
71:	1071	1071	1071	1071
72:	1072	1072	1072	1072
73:	1073	1073	1073	1073
74:	1074	1074	1074	1074
75:	1075	1075	1075	1075
76:	1076	1076	1076	1076
77:	1077	1077	1077	1077
78:	1078	1078	1078	1078
79:	1079	1079	1079	1079
80:	1080	1080	1080	1080
81:	1081	1081	1081	1081
82:	1082	1082	1082	1082

**SSSW Default Setting**

TYPE	EUROPE	GERMAN	ITALY	FRANCE
83:	1083	1083	1083	1083
84:	1084	1084	1084	1084
85:	1085	1085	1085	1085
86:	1086	1086	1086	1086
87:	1087	1087	1087	1087
88:	1088	1088	1088	1088
89:	1089	1089	1089	1089
90:	1090	1090	1090	1090
91:	1091	1091	1091	1091
92:	1092	1092	1092	1092
93:	1093	1093	1093	1093
94:	1094	1094	1094	1094
95:	1095	1095	1095	1095
96:	1096	1096	1096	1096
97:	1097	1097	1097	1097
98:	1098	1098	1098	1098
99:	1099	1099	1099	1099
100:	1100	1100	1100	1100
101:	1101	1101	1101	1101
102:	1102	1102	1102	1102
103:	1103	1103	1103	1103
104:	1104	1104	1104	1104
105:	1105	1105	1105	1105
106:	1106	1106	1106	1106
107:	1107	1107	1107	1107
108:	1108	1108	1108	1108
109:	1109	1109	1109	1109
110:	1110	1110	1110	1110
111:	1111	1111	1111	1111
112:	1112	1112	1112	1112
113:	1113	1113	1113	1113
114:	1114	1114	1114	1114
115:	1115	1115	1115	1115
116:	1116	1116	1116	1116
117:	1117	1117	1117	1117
118:	1118	1118	1118	1118
119:	1119	1119	1119	1119
120:	1120	1120	1120	1120
121:	1121	1121	1121	1121
122:	1122	1122	1122	1122
123:	1123	1123	1123	1123
124:	1124	1124	1124	1124
125:	1125	1125	1125	1125
126:	1126	1126	1126	1126
127:	1127	1127	1127	1127
128:	1131	1131	1131	1131

**SSSW Default Setting**

TYPE	EUROPE	GERMAN	ITALY	FRANCE
<b>Speech Fallback</b>				
01:	1001	1001	1001	1001
02:	1002	1002	1002	1002
03:	1003	1003	1003	1003
04:	1004	1004	1004	1004
05:	1005	1005	1005	1005
06:	1006	1006	1006	1006
07:	1007	1007	1007	1007
08:	1008	1008	1008	1008
09:	1009	1009	1009	1009
10:	1010	1010	1010	1010
11:	1011	1011	1011	1011
12:	1012	1012	1012	1012
13:	1013	1013	1013	1013
14:	1014	1014	1014	1014
15:	1015	1015	1015	1015
16:	0	0	0	0
17:	0	0	0	0
18:	1018	1018	1018	1018
19:	1019	1019	1019	1019
20:	1020	1020	1020	1020
21:	1021	1021	1021	1021
22:	1022	1022	1022	1022
23:	1023	1023	1023	1023
24:	1024	1024	1024	1024
25:	1025	1025	1025	1025
26:	1026	1026	1026	1026
27:	1027	1027	1027	1027
28:	1028	1028	1028	1028
29:	1029	1029	1029	1029
30:	1030	1030	1030	1030
31:	1031	1031	1031	1031
32:	1032	1032	1032	1032
33:	1033	1033	1033	1033
34:	0	0	0	0
35:	1035	1035	1035	1035
36:	1036	1036	1036	1036
37:	1037	1037	1037	1037
38:	1038	1038	1038	1038
39:	1039	1039	1039	1039
40:	1040	1040	1040	1040
41:	1041	1041	1041	1041
42:	0	0	0	1042
43:	1043	1043	1043	1043
44:	1044	1044	1044	1044
45:	1045	1045	1045	1045

**SSSW Default Setting**

TYPE	EUROPE	GERMAN	ITALY	FRANCE
46:	1046	1046	1046	1046
47:	1047	1047	1047	1047
48:	1048	1048	1048	1048
49:	1049	1049	1049	1049
50:	1050	1050	1050	1050
51:	1051	1051	1051	1051
52:	1052	1052	1052	1052
53:	1053	1053	1053	1053
54:	1054	1054	1054	1054
55:	1055	1055	1055	1055
56:	1056	1056	1056	1056
57:	1057	1057	1057	1057
58:	1058	1058	1058	1058
59:	1059	1059	1059	1059
60:	1060	1060	1060	1060
61:	1061	1061	1061	1061
62:	1062	1062	1062	1062
63:	1063	1063	1063	1063
64:	1064	1064	1064	1064
65:	1065	1065	1065	1065
66:	1066	1066	1066	1066
67:	1067	1067	1067	1067
68:	1068	1068	1068	1068
69:	1069	1069	1069	1069
70:	1070	1070	1070	1070
71:	1071	1071	1071	1071
72:	1072	1072	1072	1072
73:	1073	1073	1073	1073
74:	1074	1074	1074	1074
75:	1075	1075	1075	1075
76:	1076	1076	1076	1076
77:	1077	1077	1077	1077
78:	1078	1078	1078	1078
79:	1079	1079	1079	1079
80:	1080	1080	1080	1080
81:	1081	1081	1081	1081
82:	1082	1082	1082	1082
83:	1083	1083	1083	1083
84:	1084	1084	1084	1084
85:	1085	1085	1085	1085
86:	1086	1086	1086	1086
87:	1087	1087	1087	1087
88:	1088	1088	1088	1088
89:	1089	1089	1089	1089
90:	1090	1090	1090	1090
91:	1091	1091	1091	1091
92:	1092	1092	1092	1092

**SSSW Default Setting**

TYPE	EUROPE	GERMAN	ITALY	FRANCE
93:	1093	1093	1093	1093
94:	1094	1094	1094	1094
95:	1095	1095	1095	1095
96:	1096	1096	1096	1096
97:	1097	1097	1097	1097
98:	1098	1098	1098	1098
99:	1099	1099	1099	1099
100:	1100	1100	1100	1100
101:	1101	1101	1101	1101
102:	1102	1102	1102	1102
103:	1103	1103	1103	1103
104:	1104	1104	1104	1104
105:	1105	1105	1105	1105
106:	1106	1106	1106	1106
107:	1107	1107	1107	1107
108:	1108	1108	1108	1108
109:	1109	1109	1109	1109
110:	1110	1110	1110	1110
111:	1111	1111	1111	1111
112:	1112	1112	1112	1112
113:	1113	1113	1113	1113
114:	1114	1114	1114	1114
115:	1115	1115	1115	1115
116:	1116	1116	1116	1116
117:	1117	1117	1117	1117
118:	1118	1118	1118	1118
119:	1119	1119	1119	1119
120:	1120	1120	1120	1120
121:	1121	1121	1121	1121
122:	1122	1122	1122	1122
123:	1123	1123	1123	1123
124:	1124	1124	1124	1124
125:	1125	1125	1125	1125
126:	1126	1126	1126	1126
127:	1127	1127	1127	1127
128:	1131	1131	1131	1131



**SSSW Default Setting**

TYPE	EUROPE	GERMAN	ITALY	FRANCE
<b>ISDN G4 Bitswitch SW01</b>	10000100	10000100	10000100	10000100
<b>ISDN G3 Bitswitch SW01</b>	00000000	00000000	00000000	00000000
<b>ISDN G3 NUMERIC Param.</b>				
01:	90	90	90	90
02:	90	90	90	90

## 6. TEST FUNCTIONS

### 6.1 Service Test Functions

The fax functions for testing individual operations, such as below.

See *Page 3-36* for details of entering the test mode. To leave the test mode, press the *FUNCTION* button, and then > button.

#### 6.1.1 Test mode overview

Test mode can be executed by following the menu items from the display.

##### a) DRAM tests

Writes data to DRAM image storage areas and reads that data to check operations.

##### b) Print test

Prints ten different patterns within the print area.

##### c) Modem tests

These tests comprise the frequency test ,the G3 signal transmission test, and DTMF signals transmission test.

##### d) Faculty tests

These test check the operation of operation panel and sensor functions.

6.1.2 Test mode flowchart

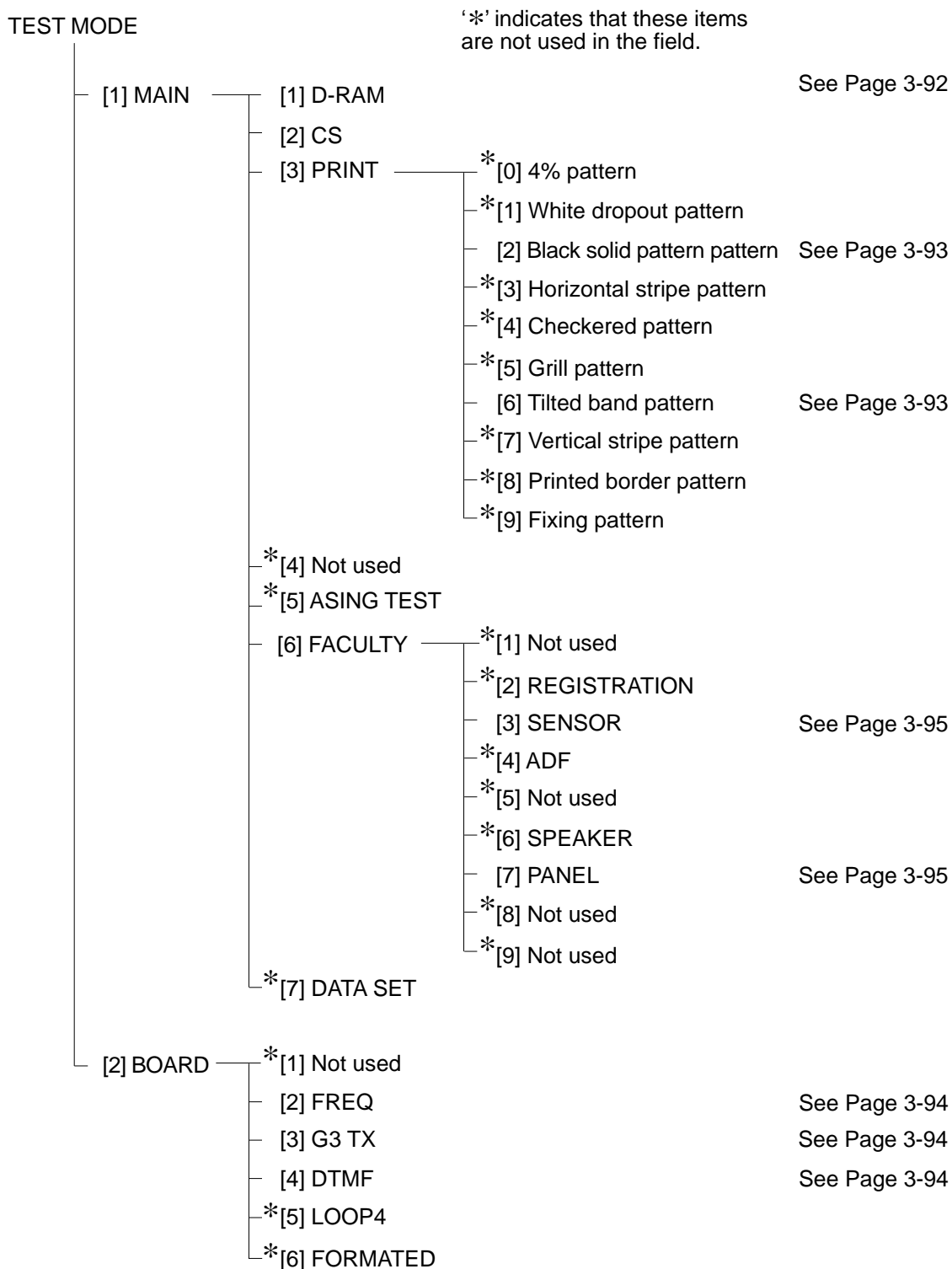

Figure 3-20 Test Mode

### 6.1.3 D-RAM tests

Pressing the 1 button from the main test mode menu selects the D-RAM tests. D-RAM Test 1 writes data to the entire D-RAM region and reads it out to check that operations are correct. D-RAM Test 2 just reads data at high speed.

**Operating**

```

1:D-RAM    3840K
-----
***. . . .***
    
```

3840K: D-RAM total memory capacity (bytes)

\* : Indicates an address for which write testing is complete.  
. : Indicates an address for which read testing is complete.

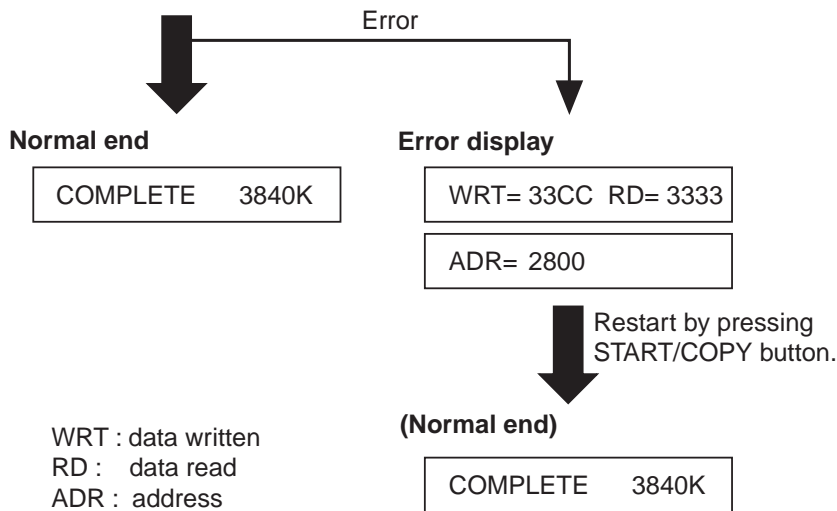

**Figure 3-21 D-RAM Test**

### 6.1.4 Print

The Print Test menu is selected by pressing the 3 key from the main test mode menu. In this test, various print patterns are output from the printer. As service print patterns, press numeric button 2 from the Print Test menu to select “3-2: Black” or press numeric button 6 to select “3-6: Endurance”. Do not use the other patterns. They are for development and factory use.

Check the following for the print pattern.

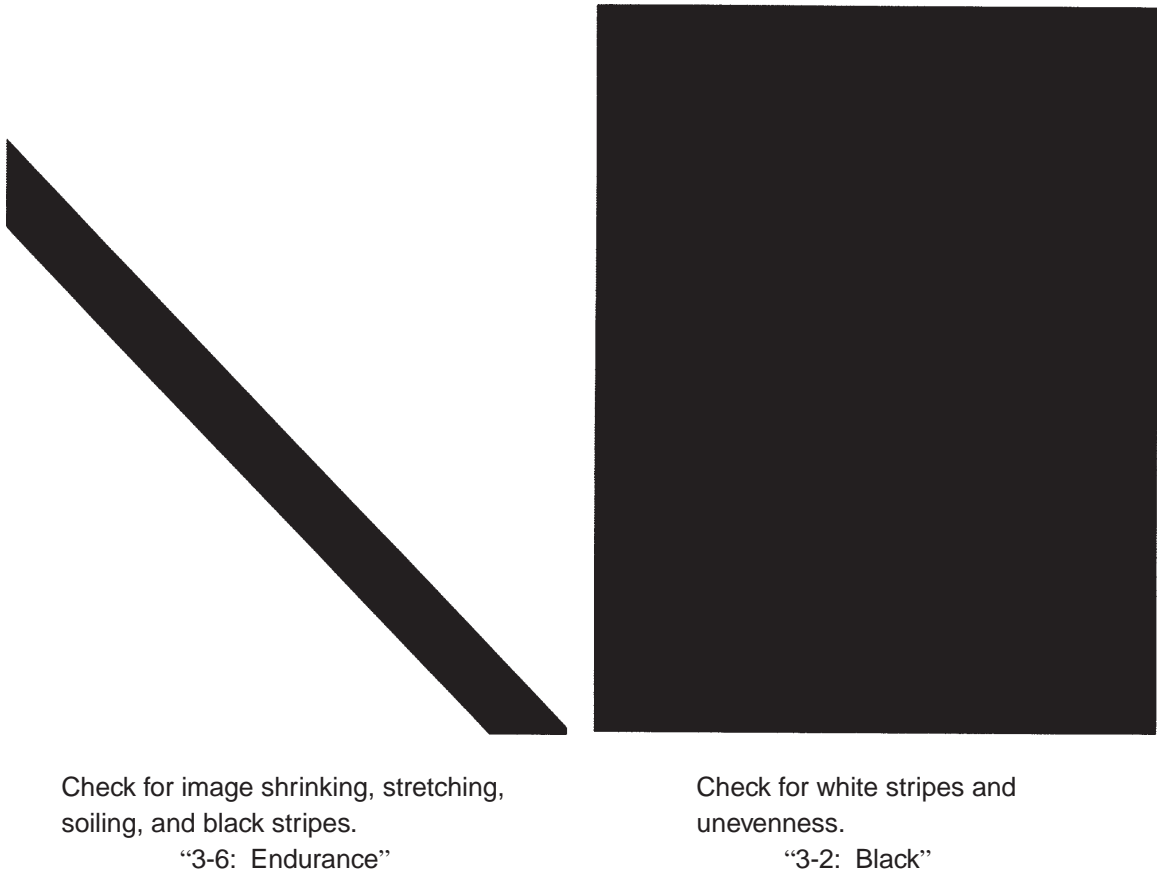

Figure 3-22 Print Pattern Check



**NOTE**

After completion of the print test, if the printing was normal, copy a document. If there is any defect in the copied image, there is a defect in the scan section.

### **6.1.5 Modem tests**

These tests test modem transmission. The modem tests check whether signals are sent correctly from the modem by comparing the sound of the signals from the speaker with the sounds from a normal modem. End this test by pressing the *STOP* button.

<b>Modem test type</b>	<b>Overview</b>
Frequency test	The modem sends tone signals from the ISDN jack and the speaker.
G3 signal transmission test	The modem sends G3 signals from the modular jack and the speaker.
DTMF signal transmission tests	The modem sends DTMF signals from the ISDN jack and the speaker.

#### **a) Frequency test**

The frequency test menu is selected by pressing numeric button 2 from the board test menu. Signals of the frequencies below are sent from the modem using the modular jack and the speaker. The frequency can be changed with the numeric buttons.

<b>Numeric button</b>	<b>Frequency</b>
1	462 Hz
2	1100 Hz
3	1300 Hz
4	1500 Hz
5	1650 Hz
6	1850 Hz
7	2100 Hz

**b) G3 signal transmission test**

The G3 signal transmission test menu is selected by pressing numeric button 3 from the board test menu. The G3 signals below are sent from the modem using the modular jack and the speaker. The frequency can be changed with the numeric buttons.

Numeric button	Frequency
0	300 bps
1	2400 bps
2	4800 bps
3	7200 bps
4	9600 bps
5	TC7200 bps
6	TC9600 bps
7	12000 bps
8	14400 bps



**NOTE**

The transmission level can be changed with the *FUNCTION* button then < and > button.

**c) DTMF signal transmission test**

The DTMF signal transmission test is selected by pressing the 4 button from the board test menu. This test checks whether the DTMF signals (0-9, \*, #) is correctly being sent across the ISDN line.

**6.1.6 Faculty tests**

The faculty tests are selected by pressing numeric button 6 from the main test mode menu. These tests check the following faculties of this fax.

Test type	Overview
Sensor tests	Test whether the sensors are operating correctly.
Operation panel test	Tests whether the button switches on the control panel are operating correctly.

**a) Sensor tests**

The sensor test is selected by pressing numeric button 3 from the faculty test menu. This test checks the status of each sensor of this fax in item 1 on the display.

Sensors that use actuators and microswitches can be checked by moving the actuator or microswitch.

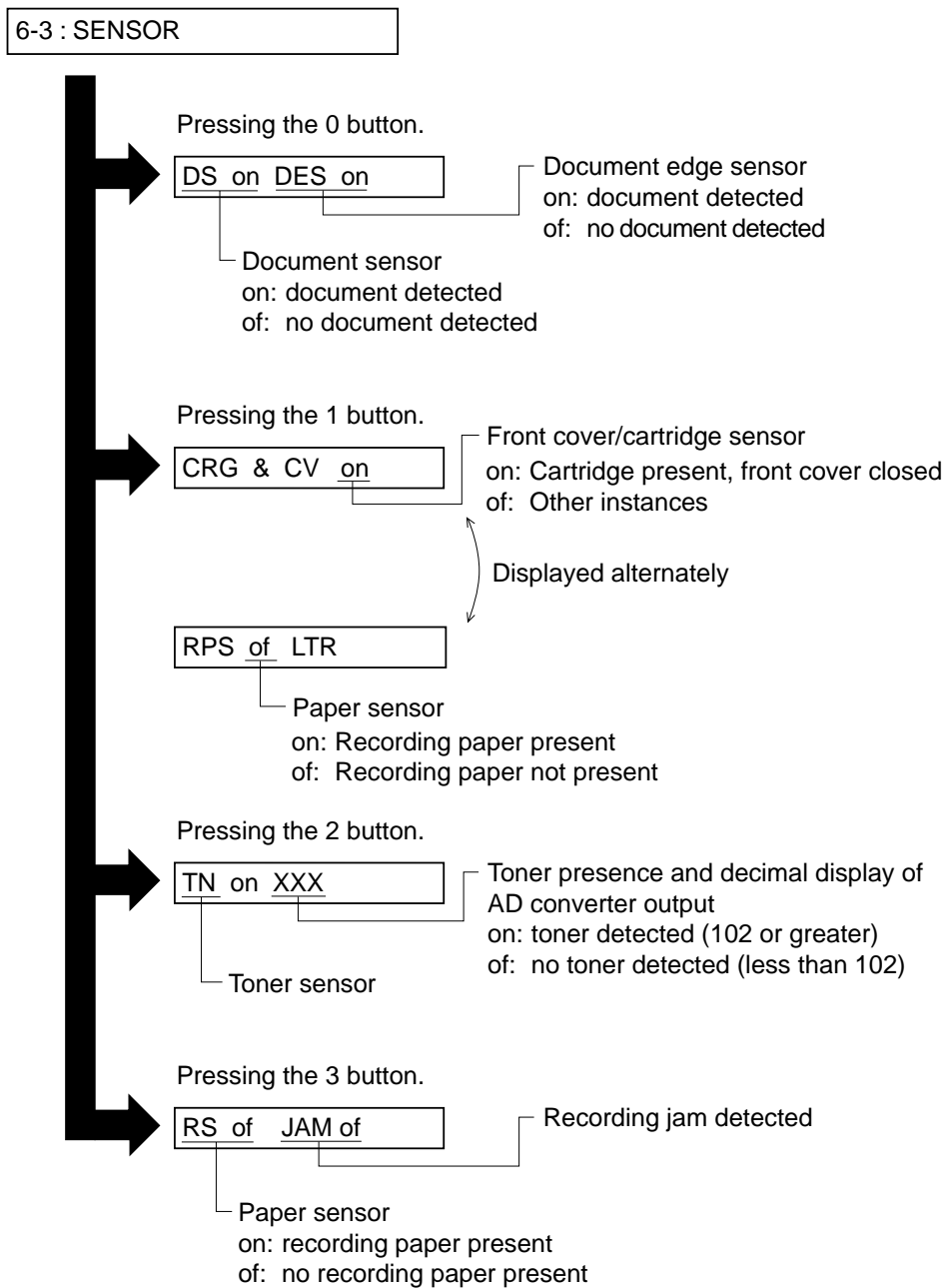

Figure 3-23 Sensor Tests



**b) Operation panel tests**

The operation panel test is selected by pressing numeric button 7 from the faculty test menu. This test checks that the display, LED lamps, and buttons on the control panel are operating correctly.

**b-1) Display test**

Pressing the *START/COPY* button from the control panel menu, "H" is displayed 16 characters by 1 line on the display. The next time the *START/COPY* button is pressed, all the LCD dots on the display are displayed. Check for any LCD dots in the display that are not displayed.

**b-2) LED lamp test**

The LED lamp test is selected by pressing the *START/COPY* button after the display test. When the *START/COPY* button is pressed, ALARM lamp on the control panel light. Check for any LED that does not light during the test.

**b-3) Operation button test**

The Operation button test is selected by pressing the *START/COPY* button after the LED lamp test. In this test, you press the button corresponding to the displayed character to put it out. The table giving the correspondence between the characters and the buttons is below.

Character	Operation button	Character	Operation button
1-#	Numeric buttons	\$	Resolution button
		&	ON-HOOK button
R	Redial button	F	Function button
D	Coded dial button		

When all the characters displayed have gone out, the system next starts the one-touch speed dialing button test. The letters a-f are displayed on the display, corresponding to one-touch speed dialing buttons 01-16. Each letter displayed on the display goes out when its corresponding one-touch speed dialing button is pressed.

In this test, check for operation buttons whose corresponding character or letter does not go out when the button is pressed.

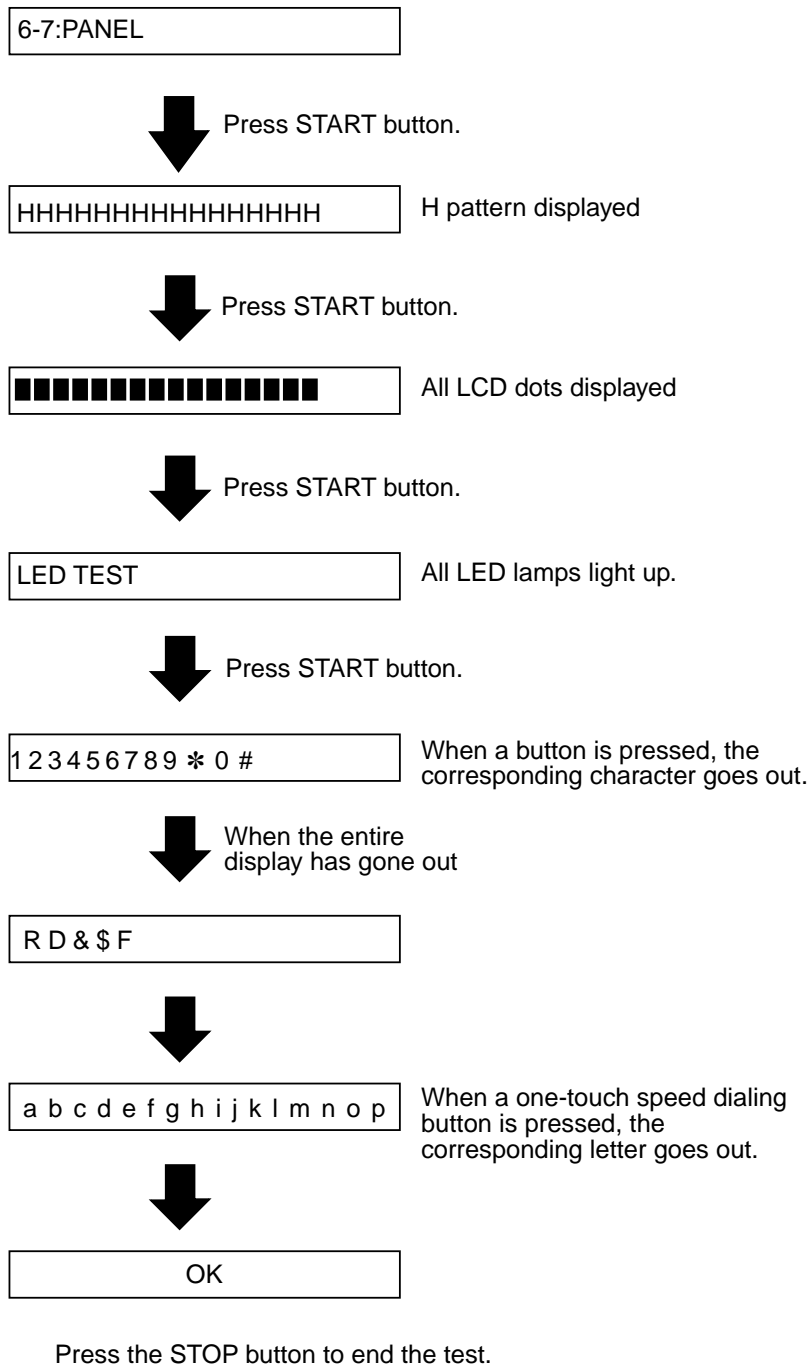

Figure 3-24 Operation Panel

## 7. SERVICE REPORT

### 7.1 Report Output Function

#### 7.1.1 User report output functions

The fax can output user reports manually, and some reports can be output automatically using the to user data settings.

##### a) Manual output of reports

<b>Report type</b>	<b>Operations</b>
Activity Report	After pressing the FUNCTION button, press the RE PORT button.
User's Data List	After pressing the FUNCTION button, use the <or> button to select "USER SETTING". After pressing the START/COPY button, press the REPORT button.
Speed Dialing Lists One-touch dial list Coded speed dial list Group dial list	Press the FUNCTION button, then use the <or> button to select "TEL REGISTRATION". After pressing the START/COPY button, press the REPORT button.
Document Memory List	After pressing the FUNCTION button, press the M E M O R Y REF button and use the <or> button to select "DOC MEMORY LIST". Then press the START/COPY button.



## 7.1.2 Service report output functions

The fax outputs current service data settings, and past communications history reports.

### a) List of service reports

The fax outputs the service reports shown below.

Report type	Operations
1. System data list	In the service mode, select the “ <b>#10 REPORT</b> ” and the desired numeric button 0 to 5. Press “1” to output the system data list. Press “2” to output the ISDN data list. Press “3” to output the system dump list. Press “4” to output the Dch dump list. Press “5” to output the Bch dump list. Press “0” to output the system data list, ISDN data list and system data list.
2. ISDN data list	
3. System dump list	
4. Dch dump list	
5. Bch dump list	
Service activity report (with service error code and dump list)	If you set bits 0 and 1 of #1 SSSW SW01 in the service mode, the service error code and dump list are indicated on the activity report (sending/receiving).



The Bch dump list cannot output in the condition it is shipped from the factory. Please change service data #4B ISDN G4 Bitswitch SW01 bit7 to “0” and then output. See *Page 3-76*.

### a-1) System data list

This list shows the current settings service data #1, #3, #5, #7, #9 and “START DATE”.



#### NOTE

“START DATE” records the date when the fax performs its first operation, after shipment from the factory.

### a-2) ISDN data list

This list shows the current settings service data #4A and #4B.



CLEAR DATE : Date on which data was initialized using service data #8 CLEAR, ALL  
 RX/TX : Total number of pages received/transmitted  
 DOC/MEM : Total number of pages directly/memory transmitted  
 A4/B4/A3/A5 : Total number of pages transmitted and received for each document size  
 14400 bps~2400 bps : Total number of pages transmitted and received for each modem speed  
 STD/FINE/  
 SUPER/ULTRA : Total number of pages transmitted and received for each mode  
 MH/MR/MMR : Total number of pages transmitted and received for each coding method  
 G4/G3/MF2/ECM : Total number of pages transmitted and received in each mode  
 PRINT/READ : Total number of pages printed/scanned

[Display example]

PRINT = 30\*/100\*\* READ = 30\*/100\*\*

\* Indicates the value input with Service Data #8 CLEAR, COUNTER.

\*\* Indicates the value counted since shipment from the factory.

#000~##750

[Display example] : Total number of occurrences for each error code

##280	1	7	3	0	0
	##280	##281	##282		
	errors	errors	errors		





**This page intentionally left blank**

a-4) Dch dump list

This list shows the D-channel communication history. Up to the latest 32 messages can be displayed.

*1	*2	*3	*4	*5
1999 01/14 THU 22:21 FAX +81 3 3758 2111	Canon Inc.			001
***** *** Dch DUMP LIST *** *****				
01/14 22:16:42	00192040	TX>	SETUP	08 01 06 05 04 03 80 90 A3 18 01 83 6C 08 00 80 33 38 34 37 32 30 70 07 80 33 38 34 37 34 30
01/14 22:16:42	00192130	<RX	CALL PROC	08 01 86 02 18 01 89
01/14 22:16:50	00200600	<RX	DISCONNECT	08 01 86 45 08 02 80 92 1E 02 82 88
01/14 22:16:50	00200690	TX>	RELEASE	08 01 06 4D
01/14 22:16:50	00200745	<RX	RELEASE COMP	08 01 86 5A
01/14 22:17:20	00230725	<RX	REL IND (L2)	
01/14 22:19:46	00376150	TX>	EST REQ (L2)	
01/14 22:19:46	00376190	<RX	EST CNF (L2)	
01/14 22:19:46	00376195	TX>	SETUP	08 01 07 05 04 02 88 90 18 01 83 6C 08 00 80 33 38 34 37 32 30 70 07 80 33 38 34 37 34 30 7C 02 88 90 7D 02 91 A1
01/14 22:19:46	00376290	<RX	CALL PROC	08 01 87 02 18 01 89
01/14 22:19:47	00377450	<RX	ALERTING	08 01 87 01
01/14 22:19:47	00377500	<RX	CONNECT	08 01 87 07 29 05 0A 00 17 0D 14 4C 08 00 81 33 38 34 37 34 30
01/14 22:19:47	00377505	TX>	CONNECT ACK	08 01 07 0F
01/14 22:19:51	00381645	TX>	DISCONNECT	08 01 07 45 08 02 80 90
01/14 22:19:51	00381750	<RX	RELEASE	08 01 87 4D 08 02 80 90 1C 15 91 A1 12 02 01 05 02 01 22 30 0A A1 05 30 03 02 01 02 82 01 01
01/14 22:19:51	00381755	TX>	RELEASE COMP	08 01 07 5A
01/14 22:20:22	00411715	<RX	REL IND (L2)	
01/14 22:20:57	00447595	TX>	EST REQ (L2)	
01/14 22:20:57	00447630	<RX	EST CNF (L2)	
01/14 22:20:57	00447635	TX>	SETUP	08 01 08 05 04 03 90 90 A3 18 01 83 1E 02 80 83 6C 08 00 80 33 38 34 37 32 30 70 07 80 33 38 34 37 34 30
01/14 22:20:57	00447730	<RX	CALL PROC	08 01 88 02 18 01 89
01/14 22:21:02	00452780	<RX	ALERTING	08 01 88 01
01/14 22:21:03	00452830	<RX	CONNECT	08 01 88 07 29 05 0A 00 17 0D 16 4C 08 00 81 33 38 34 37 34 30
01/14 22:21:03	00452835	TX>	CONNECT ACK	08 01 08 0F
01/14 22:21:08	00457850	<RX	FACILITY	08 01 88 62 1C 15 91 A1 12 02 01 05 02 01 22 30 0A A1 05 30 03 02 01 02 82 01 00
01/14 22:21:12	00462935	<RX	FACILITY	08 01 88 62 1C 15 91 A1 12 02 01 05 02 01 22 30 0A A1 05 30 03 02 01 03 82 01 00
01/14 22:21:18	00468045	<RX	FACILITY	08 01 88 62 1C 15 91 A1 12 02 01 05 02 01 22 30 0A A1 05 30 03 02 01 04 82 01 00
01/14 22:21:23	00473135	<RX	FACILITY	08 01 88 62 1C 15 91 A1 12 02 01 05 02 01 22 30 0A A1 05 30 03 02 01 05 82 01 00
01/14 22:21:28	00478235	<RX	FACILITY	08 01 88 62 1C 15 91 A1 12 02 01 05 02 01 22 30 0A A1 05 30 03 02 01 06 82 01 00
01/14 22:21:30	00480235	TX>	DISCONNECT	08 01 08 45 08 02 80 90
01/14 22:21:30	00480330	<RX	RELEASE	08 01 88 4D 08 02 80 90 1C 15 91 A1 12 02 01 05 02 01 22 30 0A A1 05 30 03 02 01 07 82 01 01
01/14 22:21:30	00480340	TX>	RELEASE COMP	08 01 08 5A

Figure 3-28 Dch Dump List

•How to View the Dch dump list

a) Title Column

- \*1: Date and Time.
- \*2: Elapsed time since the power was turned ON (msec.). Increases every 5 msec..
- \*3: Message direction.
  - TX>: The message the machine sent
  - <RX: The message the network sent
- \*4: Message Name. "(L2)" shows that the message is a Layer 2 message.
- \*5: Message's parameter. Displayed as hexadecimal numbers, 2 numbers of one octet each.

b) D-channel Layer 2 Messages

The D-channel Layer 2 message (SABME, UA, etc.) is not shown in the Dch dump list. It shows messages processed inside the machine.

- EST REQ: Machine sends SABME message
- EST CNF: The UA message is received from the network pertaining to the SABME message which was sent by the machine
- EST IND: The UA message is sent from the machine pertaining to the SABME message received by the network
- REL REQ: Machine sends a DISC message
- REL CNF: The UA message is received from the network pertaining to the DISC message sent by the machine
- REL IND: The UA message is sent from the machine pertaining to the DISC message received from the network. Additionally, depending on the cause for the removal of ISDN line, even when Layer 2 has been disconnected, the main message is still shown.

c) D-channel Layer 3 Message and Information Element

Normally, 4-octets of header information are attached to a D-channel Layer 3 message. (\*6)  
The length of the header information varies according to the value of the 2nd octet. For example, when the value of the 2nd octet is "00," the header information length is 3 octets, and when then value of the 2nd octet is "01," the header information length is 4 octets. The information elements will be displayed following the header information. (\*7)

There are 2 types of information element: single octet information element and variable length information element.

c-1) Single Octet Information Elements

The Sending Complete information element which is included in the SETUP message can be used by this machine. The service data #4B ISDN BASIC Bitswitch SW06 bit0 is set to "1," and when there is an outgoing call, on the Dch dump list right after the header information in the SETUP message sent by this machine, the main information is shown, and "A1" is set.



•Low Layer Compatibility (\*12)

Number 1 octet : "7C"

Number 3 octet : Information transfer capability

"88": Unrestricted digital

"90": 3.1kHz audio

"80": Speech

•High Layer Compatibility (\*13)

Number 1 octet : "7D"

Number 4 octet : High layer characteristics identification

"A1": G4

"84": G2/G3

"81": TEL

•Progress Indicator (\*14)

Number 1 octet : "1E"

Number 4 octet : Progress description

"81": Call is not end-to-end ISDN; further call progress information may be available in-band

"82": Destination address is non ISDN

"83": Origination address is non ISDN

"84": Call has returned to the ISDN

"85": Interworking has occurred and has resulted in a telecommunication service change

"88": In-band information or an appropriate pattern is now available

**c-4) Main information elements in the clearing message (DISC, REL, RELCOMP)**

•Cause (\*15)

Number 1 octet : "08"

Number 4 octet and on: Cause number



**NOTE**

---

**Cause number**

The "cause number" is the number which results when "80" is subtracted from the number displayed on the Dch dump list and the result is converted to decimal form. For example, in the case where the number displayed on the Dch dump list is "90," if "80" is subtracted from "90," "10" is the result. When this is converted to decimal form, "16" -the cause number - results.

**Information element description**

The actual information element description is regulated by the bit unit, but in the information descriptions in this manual assume a general situation and are shown by octet bit. If values outside of those shown in this manual appear on the Dch dump list, please check the ITU-T recommendations and the ETSI standards.

---

a-5) Bch dump list

This list shows the B-channel communication history. Up to the latest 3 communications can be displayed.



When the machine's power is turned OFF/ON, all of the information in the Bch dump list is cleared.

NOTE

```

16/01 1999 SAT 10:33 FAX +81 3 3758 2111          Canon Inc.          002

*****
***  Bch DUMP LIST  ***
*****

*1 TX/RX NO.   :   0006
*2 ERROR CODE  :  ##1336
*3 START TIME  : 16/01 10:28:16
*4 END TIME    : 16/01 10:28:20

*5 *6 *7 *8
00355355 TX> SABM 01 3F
00355365 <RX UA 01 73
00355370 TX> SQ 10 00 FB 00 00
00355395 <RX SF 10 00 FF
00355400 TX> CR 10 01 0B 00 06 42 0B 0B 43 07 07 02
00355430 <RX CC 10 01 0F 00 06 42 0B 0B 43 07 07
00355435 TX> TCR 09 E0 00 00 30 30 00 C0 01 0B
00355480 <RX TCA 09 D0 30 30 31 31 00 C0 01 0B
00355490 TX> CSS 0D 48 01 2A 0A 18 38 31 20 33 20 33 37 35 38 20
32 31 31 31 3D 43 61 6E 6F 6E 20 49 6E 63 0B 0E
39 39 2D 30 31 2D 31 36 2D 31 30 3A 32 38 02 03
0E 01 01 08 01 01 C1 08 A4 06 80 01 02 81 01 00
E8 08 00 01 11 00 01 01 00 01
00355655 <RX RSSP 0E 48 01 2A 09 18 33 38 34 37 34 31 3D 4C 47 58
69 20 47 45 52 4D 41 4E 20 20 20 20 20 20 0B 0E
39 39 2D 30 31 2D 31 36 2D 31 30 3A 32 38 02 03
0E 01 01 08 01 01 C1 08 A4 06 80 01 02 81 01 00
E8 08 00 01 11 00 01 01 00 01
00355675 TX> CDCL 01 00 3D 69 C1 4A A4 48 80 01 02 81 01 00 A2 39
A2 32 30 08 80 02 26 C0 81 02 36 CE 30 08 80 02
2E 23 81 02 41 25 30 08 80 02 2F 6D 81 02 43 2C
30 08 80 02 36 CE 81 02 4D 80 30 08 80 02 2F 6C
81 02 43 2C A4 03 8B 01 04 E4 05 E1 03 C0 01 01
E8 1B 00 01 11 00 01 01 00 01 F9 11 80 43 61 6E
6F 6E 20 49 6E 63 2E 20 20 20 20 20 20
00355780 <RX RDCLP 02 00 3E 41 C1 22 A4 20 80 01 02 81 01 00 A2 11
A2 0A 30 08 80 02 26 C0 81 02 36 CE A4 03 8B 01
04 E4 05 E1 03 C0 01 01 E8 1B 00 01 11 00 01 01
00 01 F9 11 80 4C 47 58 69 20 47 45 52 4D 41 4E
20 20 20 20 20
00355855 TX> CDS 01 00 2D 29 29 03 30 30 33 C1 22 A4 20 80 01 02
81 01 00 A2 11 A2 0A 30 08 80 02 26 C0 81 02 36
CE A4 03 8B 01 04 E4 05 E1 03 C0 01 01
00355910 TX> P-START 01 00 01 00 A2 03 02 01 00 A2 14 02 01 02 31 0F
A4 08 80 02 26 C0 81 02 36 CE E9 03 C0 01 01 A3
80 24 80
00357975 TX> P-END 01 00 01 00 00 00 00 00
00358085 TX> CDPB 01 00 31 05 2A 03 30 30 31
00358345 <RX CSA 19 03 11 01 01
00358355 TX> RSAP 1A 00
00358400 <RX CI 10 01 13 00 00
00358405 TX> CF 10 01 17
00358420 TX> RNR 01 F5
00358425 <RX RNR 03 F5
00358425 TX> RNR 03 F5
00358430 <RX RNR 01 F5
00358435 TX> DISC 01 53
00358435 <RX DISC 03 53
00358440 TX> UA 03 73
00358445 <RX UA 01 73
    
```

Figure 3-29 Bch Dump List (Erroneous Communication)

**•How to View the Bch dump list**

**a) Title Column**

- \*1: Communication Number.
- \*2: Error Code. "None" will be shown for normal communications.
- \*3: When B-channel communication has commenced.
- \*4: When B-channel communication has completed.
- \*5: Elapsed time since the power was turned ON (msec.). Increases every 5 msec.
- \*6: Message direction.
  - TX>: The message the machine sent
  - <RX: The message the network sent
- \*7: Message name.
- \*8: Message's parameter. Displayed as hexadecimal numbers, 2 numbers of one octet each.

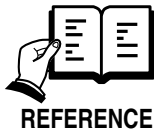

When shipped from the factory, the settings are such that only the history of errors which occur during B-channel communication are recorded. With service data settings, the full history of B-channel communication can be recorded. See page 3-76.

```

16/01 1999 SAT 10:26 FAX +81 3 3758 2111          Canon Inc.          002

*****
***  Bch DUMP LIST  ***
*****

TX/RX NO.   :    0005
ERROR CODE  :    NONE
START TIME  :   16/01 10:25:16
END TIME    :   16/01 10:25:21

00175445 TX> SABM      01 3F
00175460 <RX UA        01 73
00175460 TX> SQ        10 00 FB 00 00
00175490 <RX SF        10 00 FF
00175490 TX> CR        10 01 0B 00 06 42 0B 0B 43 07 07 02
00175520 <RX CC        10 01 0F 00 06 42 0B 0B 43 07 07
00175525 TX> TCR       09 E0 00 00 30 30 00 C0 01 0B
00175575 <RX TCA       09 D0 30 30 31 31 00 C0 01 0B
00175590 TX> CSS       0D 48 01 2A 0A 18 38 31 20 33 20 33 37 35 38 20
32 31 31 31 3D 43 61 6E 6F 6E 20 49 6E 63 0B 0E
39 39 2D 30 31 2D 31 36 2D 31 30 3A 32 35 02 03
0E 01 01 08 01 01 C1 08 A4 06 80 01 02 81 01 00
E8 08 00 01 11 00 01 01 00 01

00175765 <RX RSSP      0E 48 01 2A 09 18 33 38 34 37 34 31 3D 4C 47 58
69 20 47 45 52 4D 41 4E 20 20 20 20 20 20 0B 0E
39 39 2D 30 31 2D 31 36 2D 31 30 3A 32 35 02 03
0E 01 01 08 01 01 C1 08 A4 06 80 01 02 81 01 00
E8 08 00 01 11 00 01 01 00 01

00175780 TX> CDCL      01 00 3D 69 C1 4A A4 48 80 01 02 81 01 00 A2 39
A2 32 30 08 80 02 26 C0 81 02 36 CE 30 08 80 02
2E 23 81 02 41 25 30 08 80 02 2F 6D 81 02 43 2C
30 08 80 02 36 CE 81 02 4D 80 30 08 80 02 2F 6C
81 02 43 2C A4 03 8B 01 04 E4 05 E1 03 C0 01 01
E8 1B 00 01 11 00 01 01 00 01 F9 11 80 43 61 6E
6F 6E 20 49 6E 63 2E 20 20 20 20 20 20

00175890 <RX RDCLP     02 00 3E 41 C1 22 A4 20 80 01 02 81 01 00 A2 11
A2 0A 30 08 80 02 26 C0 81 02 36 CE A4 03 8B 01
04 E4 05 E1 03 C0 01 01 E8 1B 00 01 11 00 01 01
00 01 F9 11 80 4C 47 58 69 20 47 45 52 4D 41 4E
20 20 20 20 20

00175985 TX> CDS       01 00 2D 29 29 03 30 30 32 C1 22 A4 20 80 01 02
81 01 00 A2 11 A2 0A 30 08 80 02 26 C0 81 02 36
CE A4 03 8B 01 04 E4 05 E1 03 C0 01 01

00176045 TX> P-START  01 00 01 00 A2 03 02 01 00 A2 14 02 01 02 31 0F
A4 08 80 02 26 C0 81 02 36 CE E9 03 C0 01 01 A3
80 24 80

00177490 TX> P-END     01 00 01 00 00 00 00 00
00177610 TX> CDE       01 00 29 05 2A 03 30 30 31
00179270 <RX RDEP      02 00 2A 05 2A 03 30 30 31
00179280 TX> CSE       09 03 11 01 01
00179340 <RX RSEP      0A 00
00179345 TX> CQ        10 01 13 00 00
00179375 <RX CF        10 01 17
00179380 TX> RNR       01 35
00179390 <RX RR        01 31
00179390 TX> DISC      01 53
00179400 <RX UA        01 73
    
```

Figure 3-30 Bch Dump List (Normal Communication)







## 8. WIRING DIAGRAM

Refer to “CIRCUIT DIAGRAM” (supplied separately) for details of the connector signals.

8.2 Connector Name and Signal Descriptions on following page, contains a brief description of the input/output signals.

Refer to this description when troubleshooting.

### 8.1 Wiring Diagram

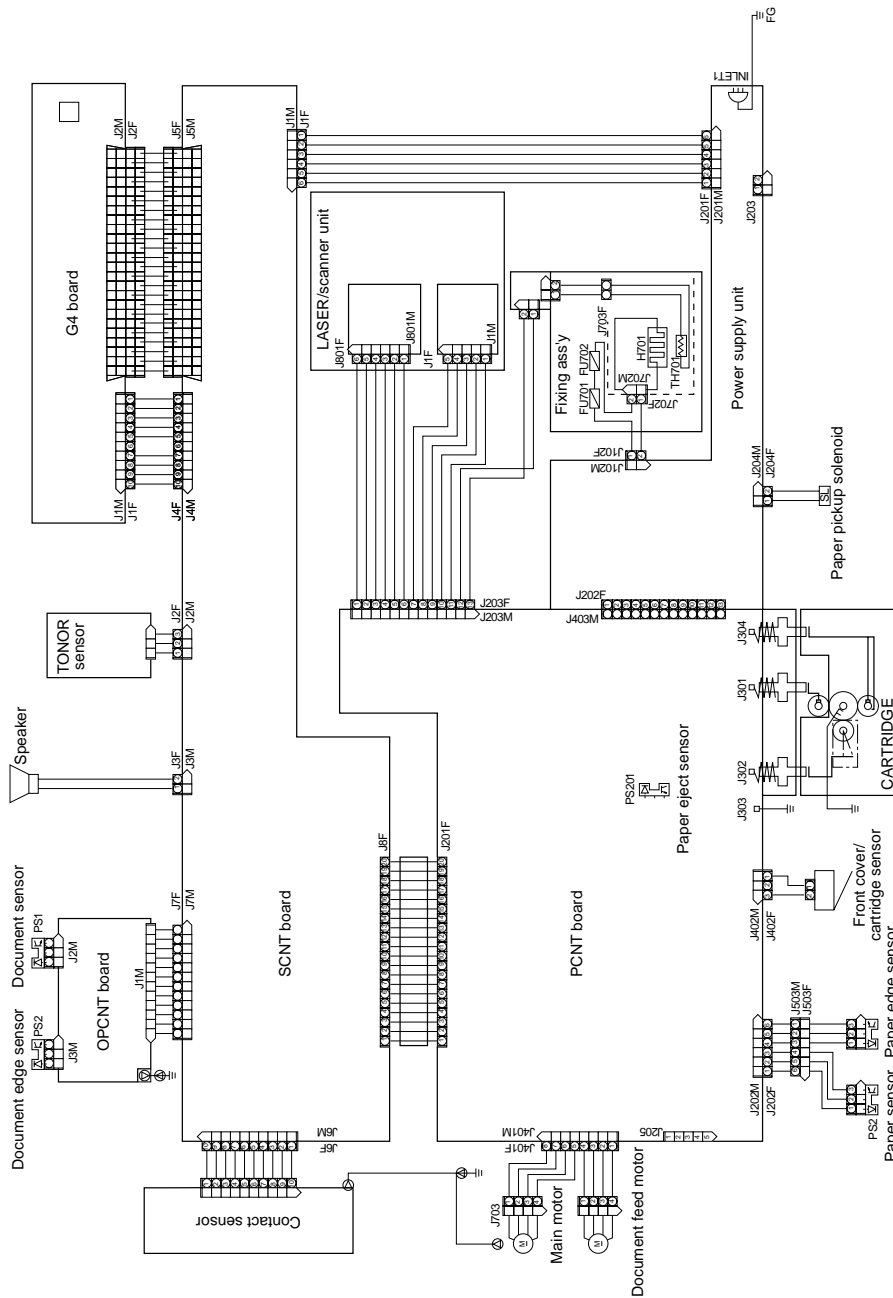

Figure 3-33 Wiring Diagram

## 8.2 Connector Name and Signal Descriptions

### SCNT board

Connector name	Connected to	Description
J1	Power supply unit (J201)	Input connector for +5V and +12V DC voltage converted by the PSU.
J2	Toner sensor	Receives detection signals from the toner sensor.
J3	Speaker	Connects to speaker.
J4	G4 board (J1)	The +5V DC from the power supply unit is supplied to the G4 board via the SCNT board. Also, the G3 communication signal sent from the G4 board to the SCNT board.
J5	G4 board (J2)	Image data is exchanged between the SCNT board and the G4 board through the centronics interface.
J6	Contact sensor	Connects between scanning section and contact sensor. Its purpose is to drive voltage for the contact sensor, and to receive image signals.
J7	Operation panel ass'y	Connects to Operation panel ass'y. Performs keyinput data exchange and LCD data exchange. This also includes document sensor and document edge sensor signals.
J8	PCNT board (J201)	Conducts data exchange of the document feed motor control signal, the printer image data and the printer commands and status.

### G4 board

Connector name	Connected to	Description
J1	SCNT board (J4)	See SCNT board (J4)
J2	SCNT board (J5)	See SCNT board (J5)

### PCNT board

Connector name	Connected to	Description
J201	SCNT board (J8)	See SCNT board (J8)
J202	Paper sensor	Receives detection signals from the paper sensor.
J203	Paper edge sensor	Receives detection signals from the paper edge sensor.
	Fixing heater	The signals for the fixing ass'y temperature controller, and the LASER and scanner motor controllers are being exchanged.
J401	Scanner unit	
	Main motor	Supplies drive voltage for the main motor.
J402	Document feed motor	Supplies drive voltage for the document feed motor.
	Front cover/ cartridge sensor	Receives detection signals from the front cover/ cartridge sensor.
J403	Power supply unit	Input connector for +5V and +12V DC voltage converted by the PSU.

**Power supply unit**

<b>Connector name</b>	<b>Connected to</b>	<b>Description</b>
J102	Fixing heater	The drive signal for the fixing heater is being exchanged.
J201	SCNT board (J1)	See SCNT board (J1)
J202	PCNT board (J403)	See PCNT board (J403)
J204	Pickup solenoid	Supplies drive voltage for the pickup solenoid.

**This page intentionally left blank**

# ***Chapter 4***

## ***Appendix***





# 1. INSTALLING THE FAX-L260i



## REFERENCE

This machine has been designed for user installation. Therefore, this manual contains only an outline description of the procedures. For details of the installation, see the *USER'S GUIDE*.

## 1.1 Setting Up

- Choosing a Location for Your FAX-L260i  
Before you set up Your FAX-L260i, make sure you have read cautions of setting up FAX-L260i.
- Unpacking Your FAX-L260i  
Check that nothing is missing when the unit is unpacked.
- Assembling the FAX-L260i
- Making Connections  
Connect the ISDN line and the power cord.
- Service Data Setting (#5 TYPE)  
Set the country type to suit the communication standard used in your country.
- The Toner Cartridge
- Loading Recording Paper  
Set paper in the auto sheet feeder, set the size of paper that is to be used.
- Entering user information  
Enter user information, such as **DATE & TIME, ENTER ISDN NO. , UNIT TELEPHONE #, UNIT NAME.**

## 1.2 Checking Operations

- Copy operation  
Make a copy, and check that the operation is normal.
- Communication test  
Transmit to, and receive from other facsimiles, and check that images are sent normally when transmitted, and are printed normally when received. Additionally, please conduct the communication test in both G4 and G3 modes.



### What to do when trouble occurs

Very rarely, during use, the display may go out, all the buttons may stop working, or some other trouble may occur because of strong electrical noise or a large amount of static. If such trouble occurs, initialize the RAM. During installation, we recommend that you perform the all clear operation after the power on. Refer to *NOTE: "ALL clear" when nothing works on Page 1-39*.

## 2. USER DATA FLOW

### 2.1 User Data Flow

The flowchart shows the default values for Europe.

For other type default, see the *User's Guide*.

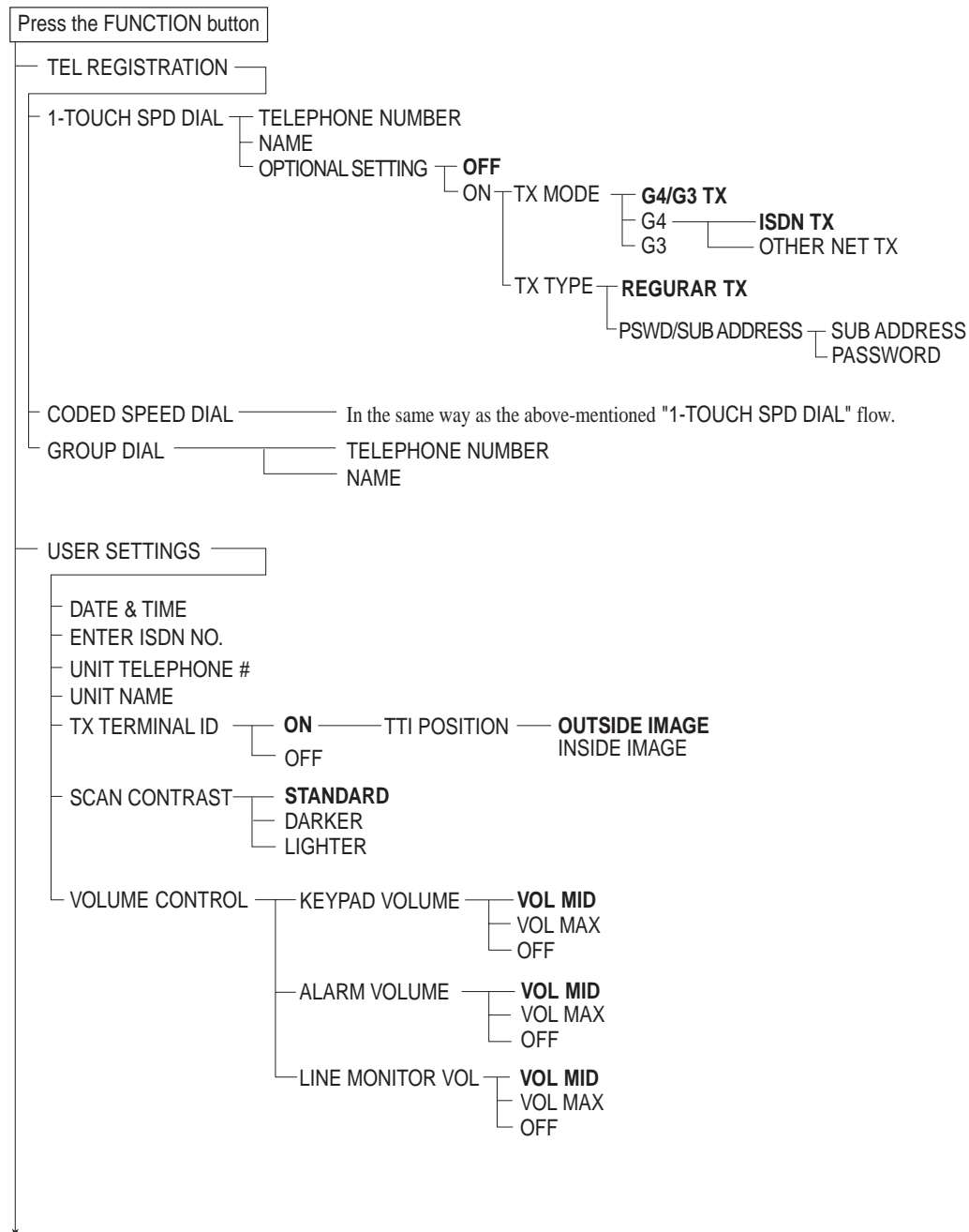

Figure 4-1 User Data Flow (1/3)

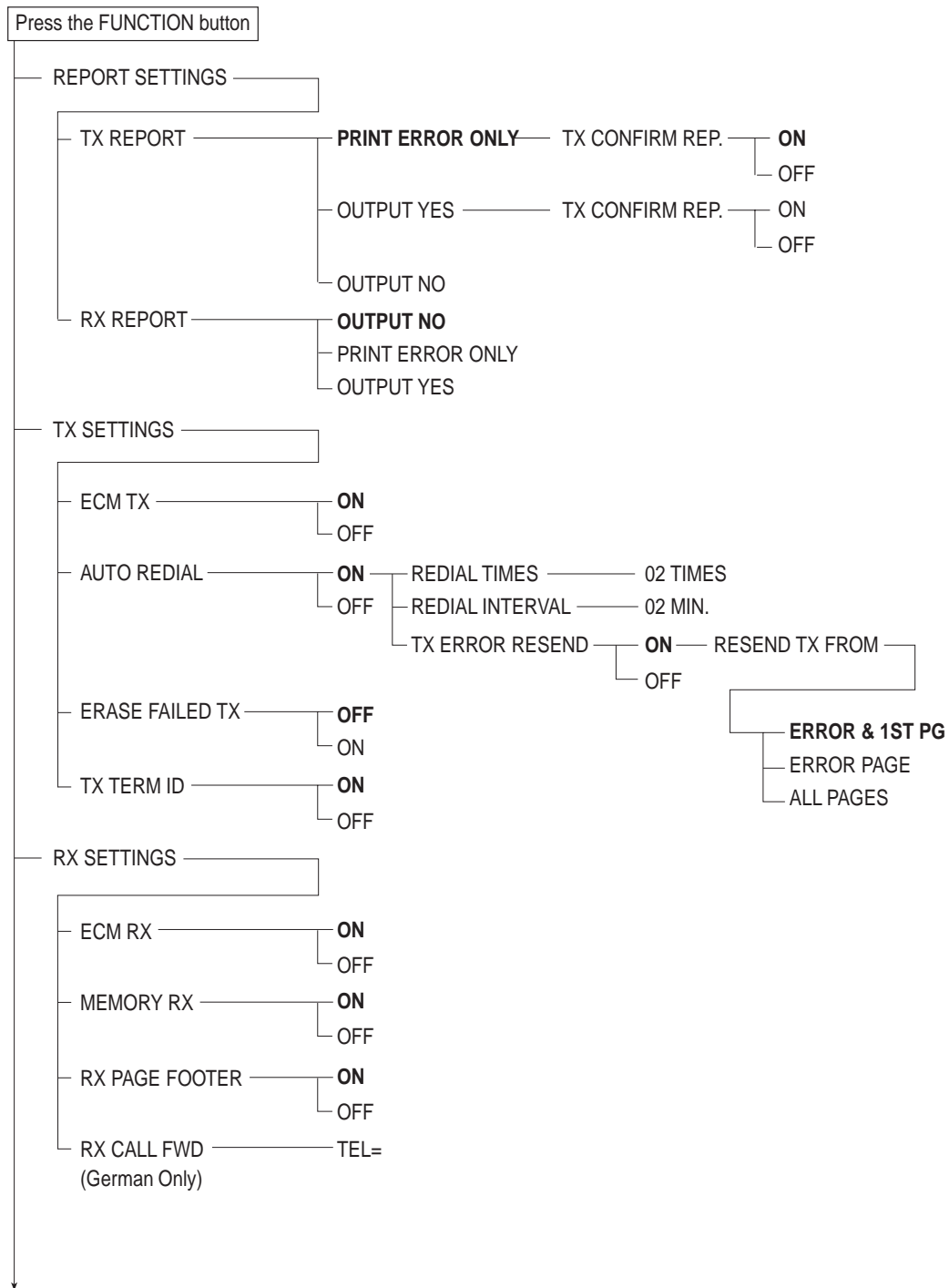

Figure 4-2 User Data Flow (2/3)

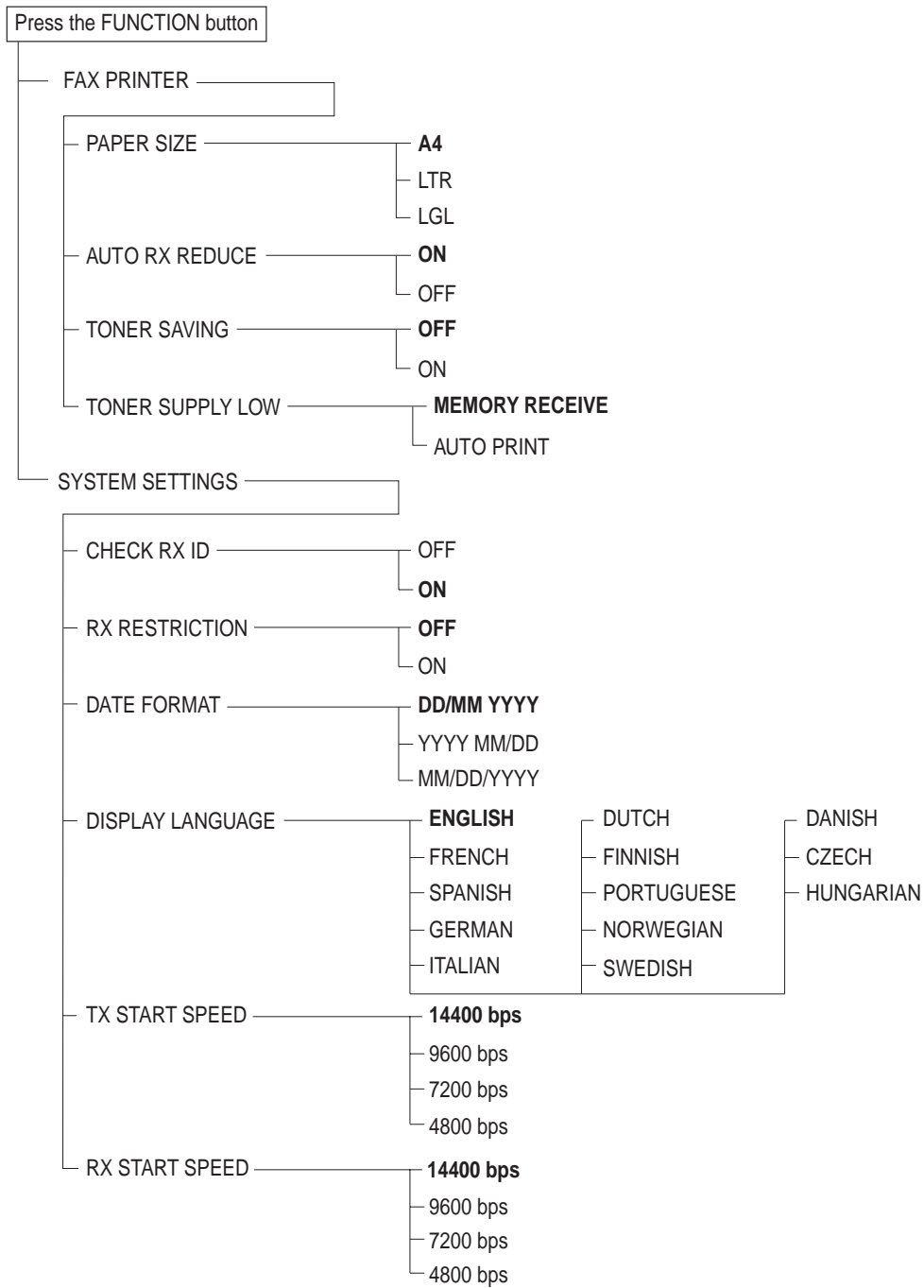

Figure 4-3 User Data Flow (3/3)

### 3. SPECIAL MODE FLOW



NOTE

#### SPECIAL MODE

The User's Guide does not contain any mention of the SPECIAL MODE. This mode is to allow user complaints to be handled by giving instructions over the telephone, without using service mode. The functions of this mode are as follows.



Using **SPECIAL MODE** while this machine is operating (faxing, or printing, etc.) will result in faulty operation.

Press the FUNCTION button then 0 button

#1 MEMORY CLEAR

SERVICE DATA  
IMAGE MEMORY  
ALL CLEAR

Figure 4-4 Special Mode Flow

#### #1 MEMORY CLEAR

**SERVICE DATA:** User data and service data #1 to #3 , #4A and #4B, #6 to #7, and system dump list contents and D-channel message log initialization.(except #5 TYPE SETTING)

**IMAGE MEMORY:** Image data initialization.

**ALL CLEAR:** All user data, service data, activity management data, and image data initialization (except #5 TYPE SETTING, COUNTER)

# 4. MAKER CODE

The 1-byte maker code displayed on the error dump list corresponds to the list of makers shown below.

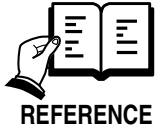

For a sample of a dump list containing maker codes, see pages 3-113-3-114

	0	1	2	3	4	5	6	7	8	9	A	B	C	D	E	F
0	0000	0001	0010	0011	0100	0101	0110	0111	1000	1001	1010	1011	1100	1101	1110	1111
1	○	○	○	○	○	○	○	○	○	○	○	○	○	○	○	○
2	○	○	○	○	○	○	○	○	○	○	○	○	○	○	○	○
3	○	○	○	○	○	○	○	○	○	○	○	○	○	○	○	○
4	△	△	△	△	△	△	△	△	△	△	△	△	△	△	△	△
5	□	□	□	□	□	□	□	□	□	□	□	□	□	□	□	□
6	MASTER NET				KONICA		MITA <sup>M</sup>				BROTHER					
7																
8	ANRITSU		IWASAKI (DEX)		OKI		CASIO		<b>Canon</b>		SANYO		SHARP		TAMURA	
9	TOSHIBA		NEC		JRC		HITACHI		FUJIEROX		FUJITSU		MATSUSHITA ELECTRIC		PANASONIC (MATSUSHITA)	
A	mitsubishi LOGIC SYSTE INTER.		MURATA		RICHO		OMRON		TOYO		NITTSUKO		MATSUSHITA COMMUNICATION		TEC	
B			OKURA		SONY		HITACHI TELECOM TECH.		HITACHI SOFTWARE		KUONI		IBM JAPAN		SILVER	
C																
D																
E																
F																

○ : National organization    △ : NTT    □ : KDD

Figure 4-5 Maker Code



Dch dump list.....	3-101	3-2
	3-106	3-6
Direct mail preventive .....	1-10	Front cover/cartridge sensor .....
DISC .....	2-28	2-2
Document Edge Sensor (DES) .....	2-2	
	2-5	<b>G</b>
Document Eject Roller .....	1-21	G3 signal transmission test .....
	2-5	3-95
	3-2	G4 board .....
	3-6	1-20
Document Feed Lever .....	2-5	2-2
	2-6	2-24
Document Feed Motor .....	1-20	3-116
	1-21	G4 Board Block Diagram .....
	1-40	2-20
	2-5	G4/G3 Fallback .....
	3-51	3-74
Document Feed Roller .....	1-21	General errors .....
	2-5	3-44
	3-2	Group dial list .....
	3-6	3-99
Document Memory List.....	3-99	
Document Sensor (DS) .....	2-2	<b>H</b>
	2-5	High Layer Compatibility .....
Document Stopper .....	2-5	2-33
DRAM .....	1-34	3-109
	2-18	High Voltage Terminal .....
	2-21	3-1
DRAM tests .....	3-90	3-6
<b>F</b>		<b>I</b>
Faculty tests .....	3-90	IF-20 .....
File No. of reservation .....	1-10	3-3
Fixing Ass'y .....	1-20	Image memory .....
	1-31	1-10
	1-40	ISDN data list .....
	3-2	3-101
	3-6	ISDN LINE .....
Fixing Entrance Guide .....	3-2	1-13
	3-6	Isopropyl alcohol .....
Fixing Section .....	1-20	3-3
	2-13	3-4
Flapper .....	2-14	
		<b>L</b>
		LASER/Scanner Section .....
		2-13
		LASER/Scanner unit .....
		1-32
		Lifting Plate .....
		2-9
		Lithium battery .....
		1-10
		1-20
		1-34
		1-36
		Low Layer Compatibility .....
		2-33
		3-109
		Lubrication points .....
		1-30
		1-31



<b>M</b>	
Main Motor .....	1-20 1-21 1-40 2-9 3-45
Maker code .....	4-6
Memory clear list .....	3-100
Modem tests .....	3-90 3-94
MOLYKOTE EM-50L .....	3-3
MSN (Multiple Subscriber Number) .....	1-5
<b>N</b>	
No-toner detection .....	2-14
<b>O</b>	
ON-HOOK button .....	1-15
ON-HOOK Dial Function .....	1-1
One-touch dial list .....	3-99
OPCNT board .....	2-2
<b>P</b>	
Paper Edge Sensor (PES) .....	2-2 2-9 2-14
Paper eject sensor .....	2-2
Paper face-down eject roller .....	1-21 2-16
Paper face-up eject roller .....	1-21 2-16 3-2 3-6
Paper Feed Guide .....	3-1 3-4
Paper feed roller .....	1-21
Paper Feed/Eject Section .....	2-14
Paper Guide .....	2-5 2-9
Paper Pickup Roller .....	3-1 3-6
Paper Sensor (PS) .....	2-2 2-9
Paper size error .....	2-10
PCNT board .....	1-20 2-2 3-116
Personnel Hazards .....	1-20
Pickup Roller .....	1-32 2-9
Pickup Solenoid .....	2-9
Polling Receiving Function .....	1-2
POLLING RX button .....	1-16
Power supply unit .....	1-20 1-22 1-33 1-40 2-2 3-117
Pressure Roller .....	1-20 3-2 3-6
Print test .....	3-90 3-93
Printing problems .....	3-45
Printing range .....	1-8
Printing speed .....	1-7
Progress Indicator .....	2-33 3-109
PWD/SUBADD button .....	1-16
<b>R</b>	
Reception footer .....	1-10
Reception image data .....	1-34
Reception image data transfer .....	1-35
Reception Image Signal .....	2-26
Recommended paper .....	1-7
Redial .....	3-76
REL .....	2-28
REL COMP .....	2-28
ROM .....	1-37 2-18 2-21 3-62 3-100

<b>S</b>		
SABME .....	2-28	
Scanning range .....	1-6	
SCNT board .....	1-20	
	1-33	
	1-37	
	2-2	
	2-24	
	3-116	
Sending Complete .....	2-33	
sensor .....	2-2	
Sensor tests .....	3-95	
Separation Guide .....	2-5	
	3-1	
	3-2	
	3-4	
Separation Pad .....	3-2	
	3-6	
Separation Roller .....	1-21	
	2-5	
	3-1	
	3-4	
Service activity report .....	3-101	
	3-113	
Service Data Settings .....	3-54	
	3-56	
Service error code .....	3-14	
Service report .....	1-10	
SETUP .....	2-28	
	2-33	
SPECIAL MODE .....	4-5	
Speech Fallback .....	3-74	
SRAM .....	1-36	
	2-18	
SSSW .....	3-64	
	3-79	
Static Charge Eliminator .....	3-1	
	3-6	
Static Eliminator Brush .....	2-5	
Subaddress/Password Communications		
Function .....	1-1	
Supplementary service .....	1-5	
System data list .....	3-101	
		3-101
		3-102
		<b>T</b>
TEST MODE .....	3-62	
	3-90	
	3-91	
Toner Cartridge .....	1-29	
	2-13	
Toner sensor: .....	2-2	
Toner Transfer Section .....	2-13	
Transfer Charging Roller .....	1-31	
	3-1	
	3-6	
Transmission Image Signal .....	2-24	
Transmission time .....	1-4	
Troubleshooting .....	3-9	
		<b>U</b>
Upper Document Eject Roller .....	2-5	
Upper Document Feed Roller .....	2-5	
UA .....	2-28	
User Data Flow .....	4-2	
User error code .....	3-14	
User error message .....	3-10	
User report .....	1-10	
	3-99	
User's Data List .....	3-99	
		<b>W</b>
White Sheet .....	2-5	
	3-1	
	3-4	
Wiring Diagram .....	3-115	

0299AB0.30-0  
0699AB0.30-0



Printed on paper that  
contains 60% reused paper.

**Canon**

# FAX-L260i

## PARTS CATALOG

REVISION 1

[ FAX-L260i

H12-1413 230V EC ]

**Canon**

JUNE 1999

**HY8-30AG-010**

## **Application**

This manual has been issued by Canon Inc. for qualified persons to learn technical theory, installation, maintenance, and repair of products. This manual covers all localities where the products are sold. For this reason, there may be information in this manual that does not apply to your locality.

## **Corrections**

This manual may contain technical inaccuracies or typographical errors due to improvements or changes in products. When changes occur in applicable products or in the content of this manual, Canon will release technical information as the need arises. In the event of major changes in the contents of this manual over a long or short period, Canon will issue a new editions of this manual.

**The following paragraph does not apply to any countries where such provisions are inconsistent with local law.**

## **Trademarks**

The product names and company names described in this manual are the registered trademarks of the individual companies.

## **Copyright**

This manual is copyrighted with all rights reserved. Under the copyright laws, this manual may not be copied, reproduced or translated into another language, in whole or in part, without the written consent of Canon Inc.

**Copyright © 1999 by Canon Inc.**

**CANON INC.**

**Office Imaging Products Technical Support Dept. 3**

**5-1 Hakusan 7-Chome, Toride-city, Ibaraki 302-8501, Japan**

## **DTP System**

The data contained on this manual were created using Apple Macintosh® computers.

Document creation and page layout were performed using Adobe® PageMaker® 6.5J.

Logos and illustrations were created using Macromedia® FreeHand 8.0J.

# I. CONTENTS

1. ILLUSTRATION INDEX
2. PARTS LAYOUT & PARTS LIST
3. TOOL
4. LUBRICATIONS
5. GUIDE TO REPLACEMENT
6. NUMERICAL INDEX

## II. ABOUT THIS MANUAL

### 1. ILLUSTRATION INDEX

For illustration index, the parts layout illustrations in this parts catalog are listed in abbreviated form in order of illustration number to identify the pages they appear on. To find an illustration of a part, see the ILLUSTRATION INDEX.

### 2. PARTS LAYOUT & PARTS LIST

#### Parts layout illustration

##### a) Parts search

Find a part from the parts layout illustration and find its key number from the parts list to identify the part number and name.

Further, screws, nuts, washers, grip rings, pins and spacers are mentioned in the parts list.

**Note:** If parts have the same or similar shape but different specifications, their key number is assigned to several part numbers and names in the parts list.

##### b) Parts replacement procedure

The parts layout illustrations are arranged according to the disassembly procedure of the product.

When a unit in the illustration can be disassemble further, a reference illustration page of the disassembly will be included.

Parts where grease is to be applied are displayed as "Lubrication". When replacing parts, or if grease has accidentally been wiped off, refer to "4". (Lubrications), and reapply the grease.

The parts require carefully work are marked "See page 5-x". So refer to the corresponded page "5". (GUIDE TO REPLACEMENT).

The letters (A), (B) etc.) in the illustration indicate the connection locations of cables and screws.

#### Parts list

##### a) FIGURE & KEY No.

The FIGURE & KEY No. column corresponds to the key numbers assigned to the parts in the parts layout illustration.

It also corresponds to the part locations printed on the PC board.

##### b) PART NUMBER

The PART NUMBER column gives the part numbers corresponding to the key numbers. To order a part, indicate the part number clearly.

**Note:** Parts marked NPN are not service parts.

##### c) RANK

The service parts with N in the RANK column are order parts.

##### d) QTY

The QTY column gives the number of parts in the corresponding components layout illustration.

##### e) DESCRIPTION

The DESCRIPTION column gives the part names in English.

To order a part, indicate the part name, too.

### 3. TOOL

This is a list of tools used for servicing products.

### 4. LUBRICATIONS

Where grease is to be applied in order to allow moving parts to work smoothly, and to increase conductivity, the type and amount of grease to be used will be mentioned.

### 5. GUIDE TO REPLACEMENT

Explains the special cares and cautions for the parts replacement.

### 6. NUMERICAL INDEX

All the parts listed in this parts catalog are arranged in order of part number. You can identify part locations and names from the NUMERICAL INDEX.



### III. REVISION HISTORY

REVISION	CONTENT
0	Original
1	Updates to Service Information HS-E5E-9014-01, as issued by Canon Inc.

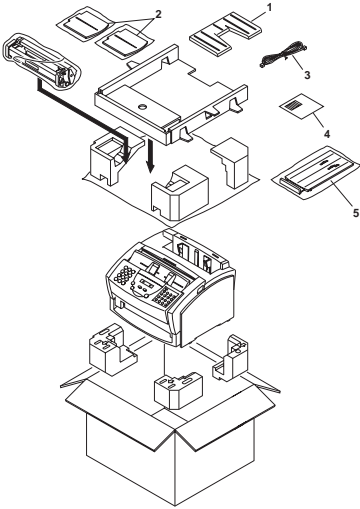
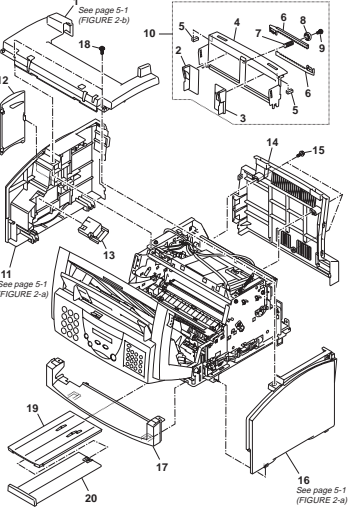
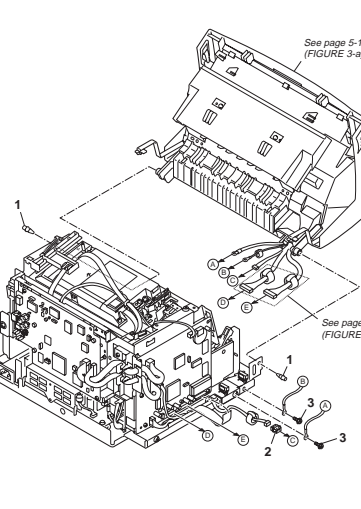
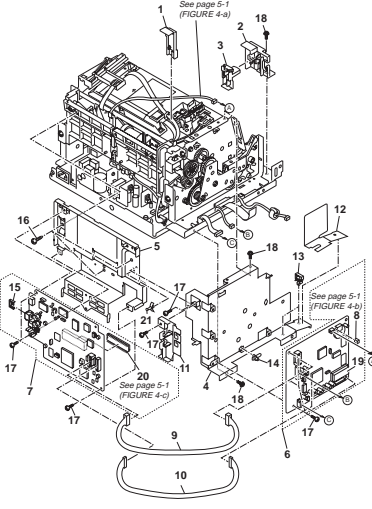
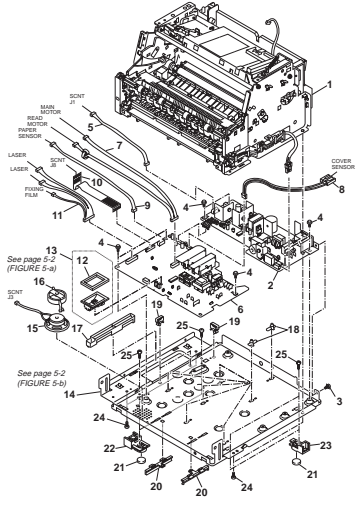
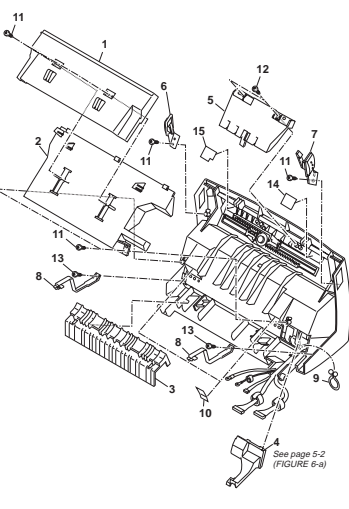
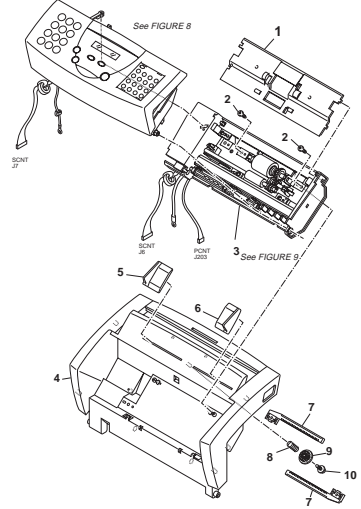
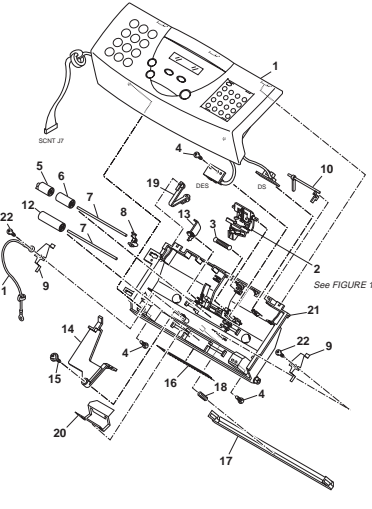

# 1. ILLUSTRATION INDEX

<p><b>FIGURE 1</b> FAX-L260i PACKAGE CONTENTS</p>	<p>See Page 2-1</p>	<p><b>FIGURE 2</b> COVERS &amp; TRAY ASSY</p>	<p>See Page 2-2</p>	<p><b>FIGURE 3</b> READING ASS'Y &amp; MAIN FRAME</p>	<p>See Page 2-3</p>	<p><b>FIGURE 4</b> CIRCUIT BOARDS &amp; MAIN FRAME</p>	<p>See Page 2-4</p>
							
<p><b>FIGURE 5</b> CIRCUIT BOARDS &amp; BOTTOM PLATE</p>	<p>See Page 2-5</p>	<p><b>FIGURE 6</b> READING ASS'Y 1</p>	<p>See Page 2-6</p>	<p><b>FIGURE 7</b> READING ASS'Y 2</p>	<p>See Page 2-7</p>	<p><b>FIGURE 8</b> OPERATION PANEL ASS'Y &amp; ADF UPPER</p>	<p>See Page 2-8</p>
							

<p><b>FIGURE 9</b> ADF LOWER</p>	<p>See Page 2-9</p>	<p><b>FIGURE 10</b> SCANNER ASS'Y</p>	<p>See Page 2-10</p>	<p><b>FIGURE 11</b> FIXING SECTION 1</p>	<p>See Page 2-11</p>	<p><b>FIGURE 12</b> DRIVE GEARS</p>	<p>See Page 2-12</p>
<p><b>FIGURE 13</b> FIXING SECTION 2</p>	<p>See Page 2-13</p>	<p><b>FIGURE 14</b> PAPER FEED SECTION</p>	<p>See Page 2-14</p>	<p><b>FIGURE 15</b> PICK-UP ROLLER ASS'Y</p>	<p>See Page 2-15</p>	<p><b>FIGURE 16</b> SEPARATION GUIDE ASS'Y (READING)</p>	<p>See Page 2-16</p>

FIGURE 17 FEEDER ASS'Y

See Page 2-17

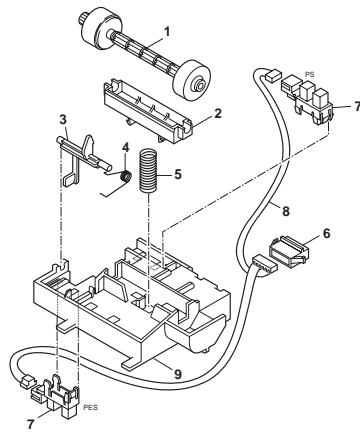

FIGURE 18 DELIEVRY ASS'Y

See Page 2-18

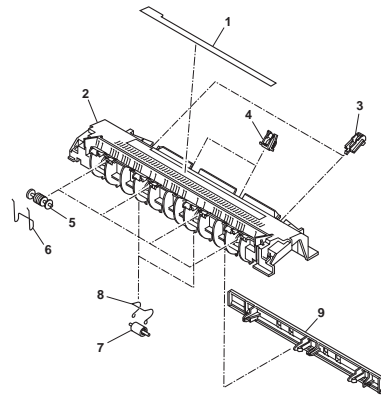

FIGURE 19 TRANSFER BLOCK ASS'Y

See Page 2-19

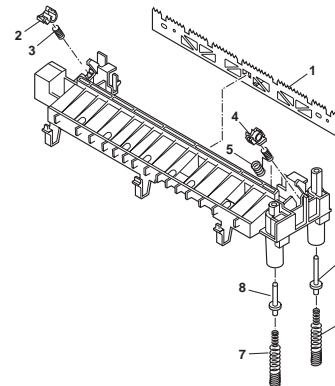

FIGURE 20 SEPARATION GUIDE ASS'Y (RECORDING)

See Page 2-20

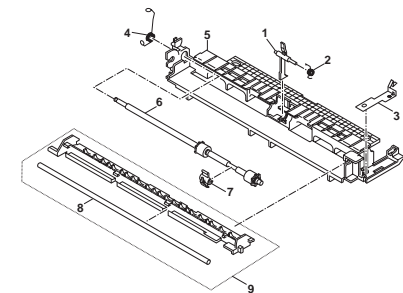

FIGURE 21 TOOLS

See Page 3-1

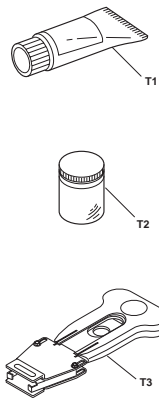





FIGURE 2 COVERS & TRAY ASS'Y

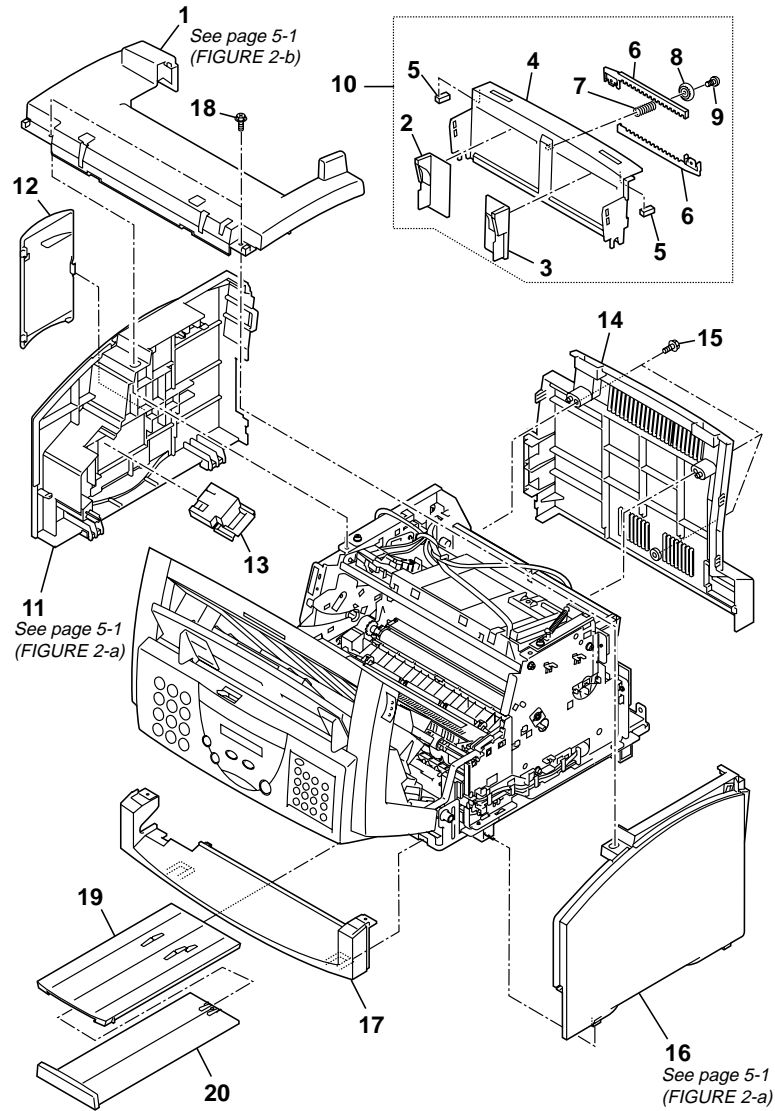

FIGURE & KEY No.	PART No.	RANK	QTY	DESCRIPTION	REMARKS
2 - 1	HB1-2980-000		1	COVER, UPPER	
2	HB1-3003-000		1	GUIDE, AUTO PAPER FEED, LEFT	
3	HB1-3004-000		1	GUIDE, AUTO PAPER FEED, RIGHT	
4	HB1-3002-000		1	TRAY, AUTO PAPER FEED	
5	HB1-3211-000		1	SHEET, TRAY	
6	HB1-3008-000		2	RACK	
7	HS5-2141-020		1	SPRING, SLIDER	
8	HS5-0254-000		1	GEAR, Z16	
9	XA9-0476-000		1	SCREW, TP M3X8	
10	HG5-1292-020		1	AUTO PAPER FEED ASS'Y	
11	HB1-3688-000		1	COVER, LEFT	
12	HB1-2992-000		1	COVER, ROM	
13	HB1-3049-000		1	SUPPORT, STOPPER	
14	HB1-3689-000		1	COVER, REAR	
15	XB6-7300-807		3	SCREW, TP, M3X8	
16	HB1-2982-040		1	COVER, RIGHT	
17	HB1-2984-030		1	COVER, FRONT	
18	XA9-0879-000		2	SCREW, RS M3X10	
19	HB1-2987-000		1	TRAY, PAPER OUTPUT	
20	HB1-1230-000		1	PAPER OUT PUT EXTENSION	





FIGURE 4 CIRCUIT BOARDS & MAIN FRAME

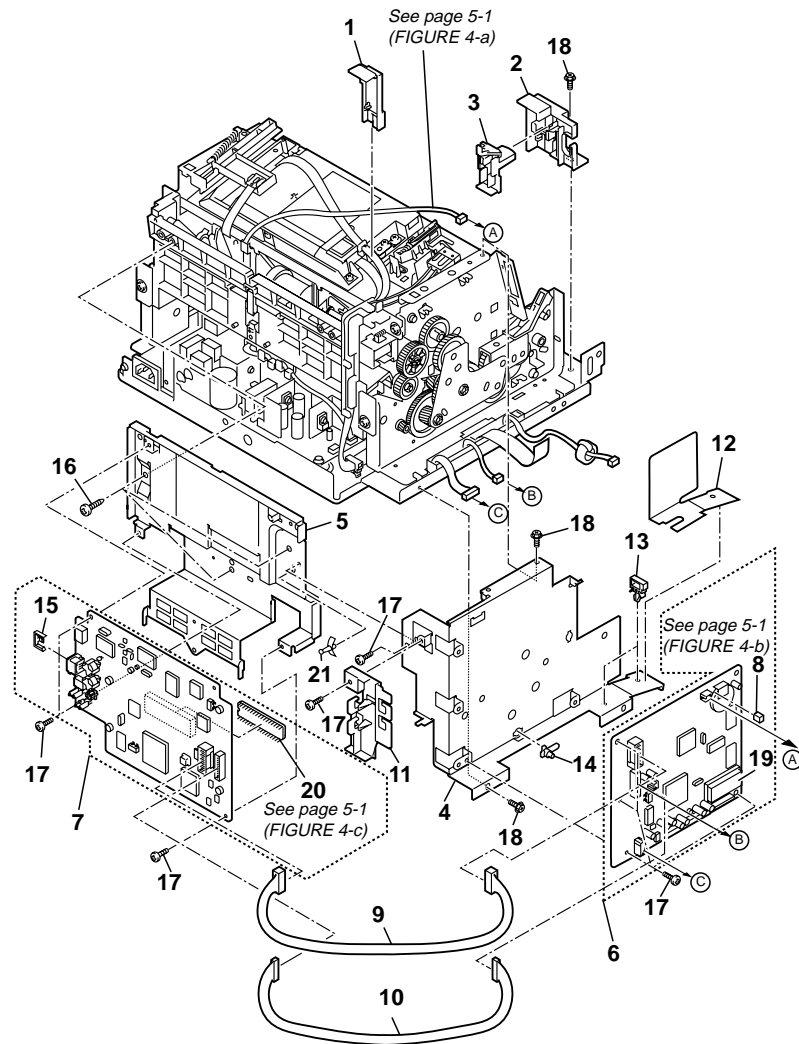

FIGURE & KEY No.	PART No.	RANK	QTY	DESCRIPTION	REMARKS
4 - 1	HB1-3043-000		1	COVER, FIXING SECTION, RIGHT	
2	HB1-3042-000		1	COVER, FIXING SECTION, LEFT	
3	HB1-2985-000		1	LEVER, SWITCHING	
4	HB1-3027-030	N	1	HOLDER, SCNT BOARD	
5	HB1-3690-000	N	1	HOLDER, G4 BOARD	
<hr/>					
6	HG5-1830-000		1	SCNT BOARD ASS'Y	
7	HG5-1831-000		1	G4 BOARD ASS'Y	
8	WS1-5397-000	N	1	PLUG, JUMPER	
9	HH2-2852-000		1	CABLE WITH CONNECTOR, 24P	
10	HH2-2853-000		1	CABLE WITH CONNECTOR, 10P	
<hr/>					
11	HB1-3691-000		1	GUIDE, CABLE	
12	HB1-3028-000		1	SHEET, CORE GARD	
13	WT2-0317-000		2	CLIP, CABLE	
14	HB1-3022-000		1	SPACER	
15	HB1-3692-000		1	SPACER, MODULAR JACK	
<hr/>					
16	XB4-7401-007		3	SCREW, PAN HEAD SELF-TAPPING	
17	XB1-2300-807		9	SCREW, CROSS-RECESS, FCH	
18	XA9-0724-000		3	SCREW, M3X8	
19	HH4-3211-000		1	IC, LH538N3D, MASK-ROM	
20	HH4-3213-000		1	IC,UPD23C8000XCZ-224,MASK-ROM	
21	VT2-0002-000	N	1	SPACER, SUPPORT	
<hr/>					

**FIGURE 5 CIRCUIT BOARDS & BOTTOM PLATE**

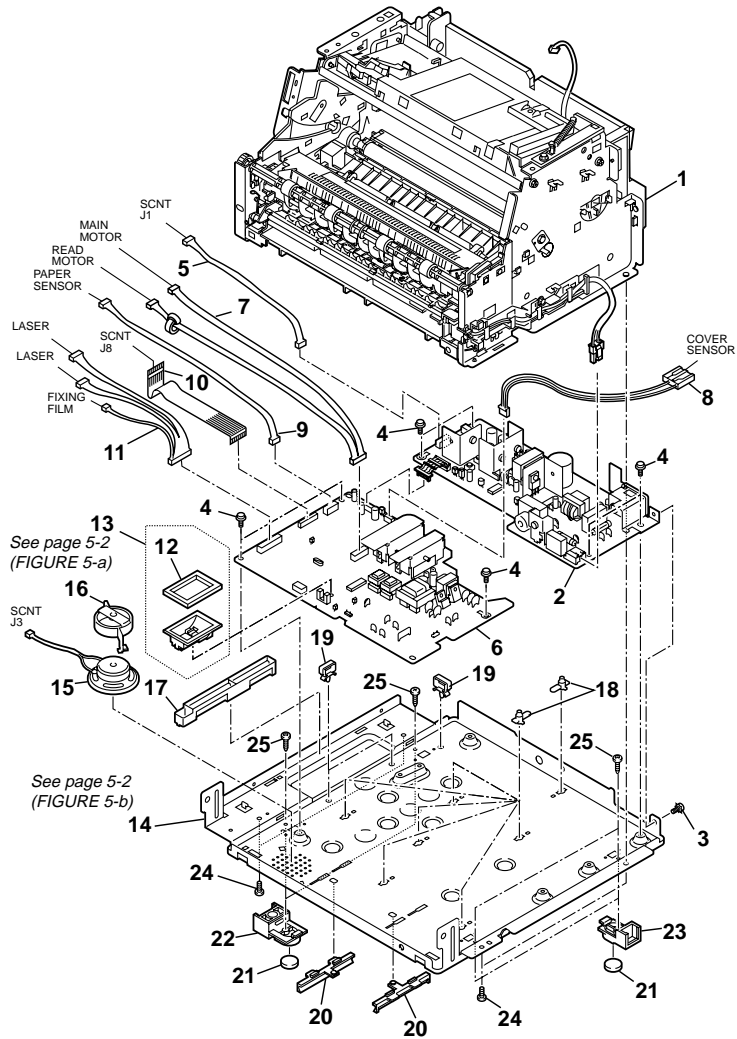

FIGURE & KEY No.	PART No.	RANK	QTY	DESCRIPTION	REMARKS
5 - 1	NPN		1	FRAME UNIT	
2	HH3-5332-000		1	POWER SUPPLY UNIT	
3	XB2-7300-607		1	SCREW, M3X6	
4	XA9-0863-000		7	SCREW, TAP M3X6	
5	HH2-2762-000		1	CABLE ASSEMBLY	
6	HG5-1304-000		1	PCNT BOARD ASS'Y	
7	HH2-2870-000		1	CABLE ASSEMBLY	
8	HH2-2768-000		1	CABLE WITH CONNECTOR, 2P	
9	HH2-2760-000		1	CABLE WITH CONNECTOR, 6P	
10	HH2-2758-000		1	FLAT CABLE	
11	HH2-2759-000		1	CABLE ASSEMBLY	
12	RB1-7270-000		1	CUSHION	
13	RF5-2382-000		1	COVER, WATERPROOF	
14	HB1-3020-030	N	1	PLATE, BOTTOM	
15	HH7-2287-000		1	SPEAKER UNIT	
16	HB1-3023-000		1	HOLDER, SPEAKER	
17	HB1-3021-000		1	GUIDE, CABLE	
18	HB1-3022-000		7	SPACER	
19	WT2-0317-000		3	CLIP, CABLE	
20	HB1-3026-050		2	RAIL, OUTPUT TRAY	
21	HB1-3212-000		4	FOOT, RUBBER	
22	HB1-3024-040		2	FOOT, LEFT	
23	HB1-3025-040		2	FOOT, RIGHT	
24	XA9-0724-000		4	SCREW, M3X8	
25	XB4-7300-607		4	SCREW, TAP TIGHT, BINDING HEAD	

FIGURE 6 READING ASS'Y 1

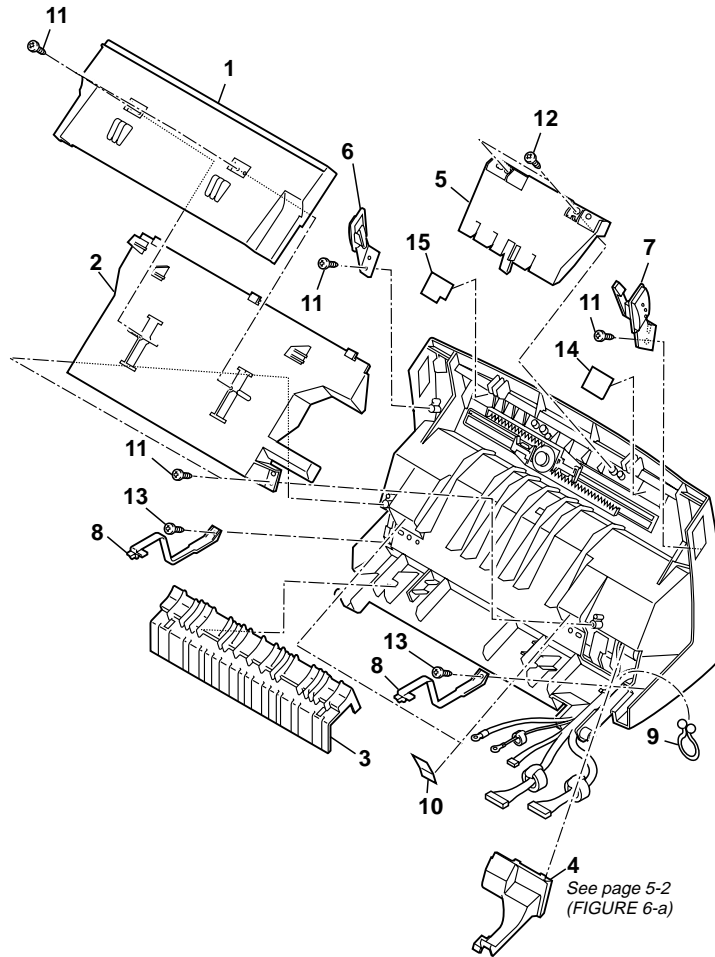

FIGURE & KEY No.	PART No.	RANK	QTY	DESCRIPTION	REMARKS
6-1	HB1-3001-000		1	AIR DUCT	
2	HB1-2996-000		1	AIR DUCT	
3	HB1-2997-000		1	GUIDE, FACE DOWN	
4	HB1-3105-000		1	COVER, CABLE	
5	HB1-3010-030		1	SUPPORT, TRAY	
6	HB1-3009-050		1	RELEASE BUTTON, RIGHT	
7	HB1-3000-050		1	RELEASE BUTTON, LEFT	
8	HB1-3109-020		2	STOPPER, CRG	
9	WT2-5569-000		1	CLIP, CABLE	
10	HB1-1870-000		1	SHEET	
11	XB4-7301-007		6	SCREW, TAP TIGHT BH3X10	
12	XB4-7300-809		2	SCREW, TAP, BINDING HEAD, M3X8	
13	XB4-7301-409		2	SCREW, TAPPING M3X14	
14	HB1-3044-000		1	SHEET, PAPER EJECT (L)	
15	HB1-3045-000		1	SHEET, PAPER EJECT (R)	



FIGURE 8 OPERATION PANEL ASS'Y & ADF UPPER

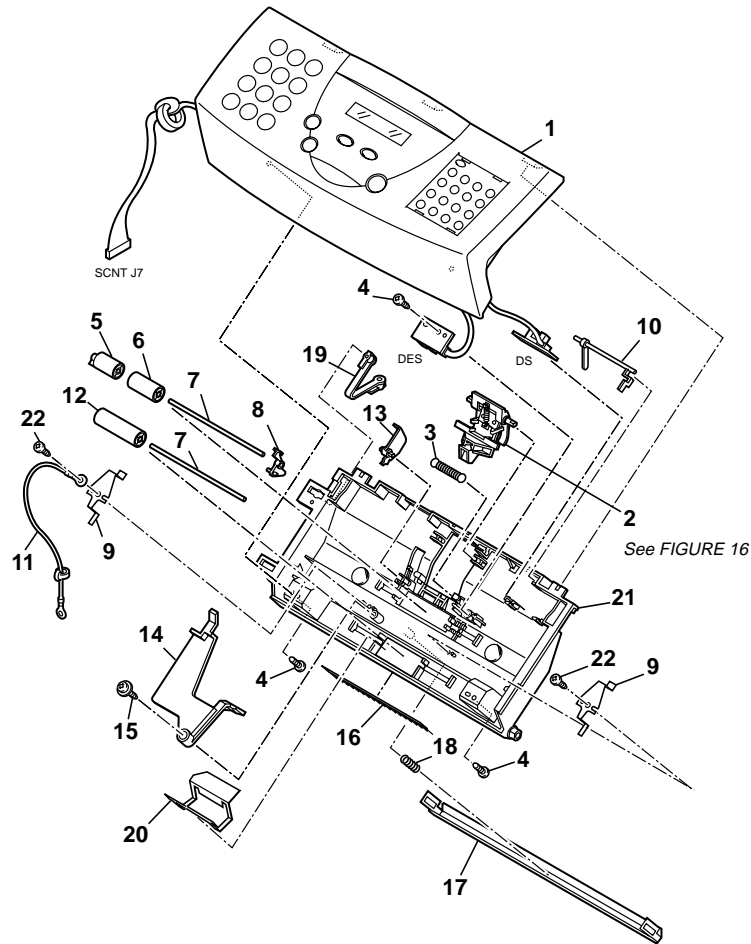
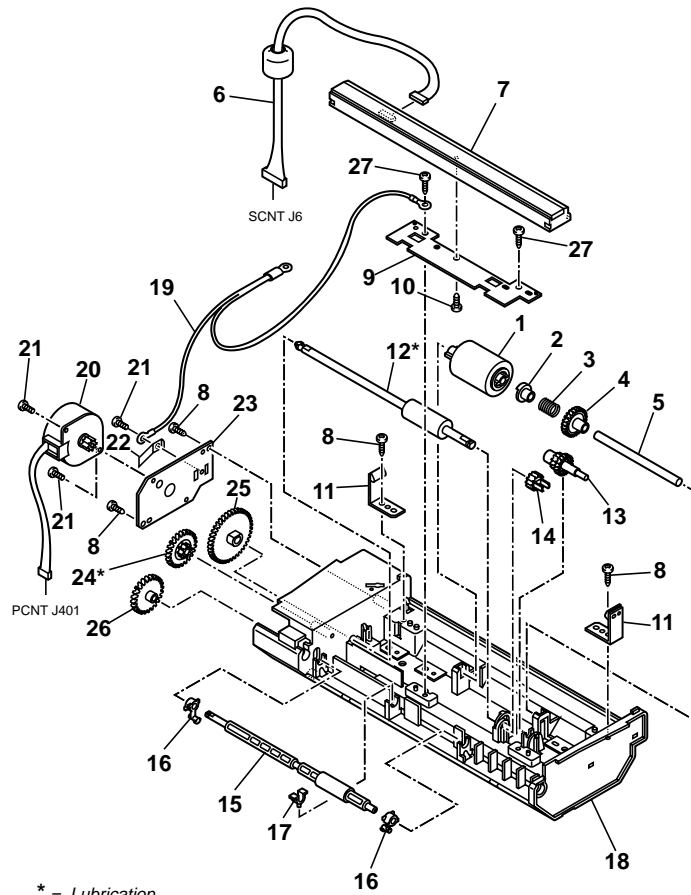

FIGURE & KEY No.	PART No.	RANK	QTY	DESCRIPTION	REMARKS
8 - 1	HH7-2303-000		1	OPERATION PANEL ASS'Y	
2	HG5-1308-000		1	SEPARATION GUIDE ASS'Y	
3	HS5-2078-000		1	SPRING	
4	XB4-7301-007		3	SCREW, TAP TIGHT BH3X10	
5	HB1-2864-000		1	ROLLER, BACK UP	
6	HS5-6023-030		1	ROLLER, BACK UP	
7	HB1-2865-000		2	SHAFT, BACK UP ROLLER	
8	HB1-2861-000		1	ARM, DETECTION (DES)	
9	HB1-2866-000		2	PLATE, PRESSURE	
10	HB1-2862-000		1	ARM, DETECTION (DS)	
11	HH2-2814-000		1	WIRE, GROUNDING	
12	HS5-6042-000		1	ROLLER, DELIVERY, 2	
13	HB1-2863-000		1	STOPPER, DOCUMENT	
14	HB1-3041-000		1	LEVER, DOCUMENT RELEASE	
15	XA9-0476-000		1	SCREW, TP M3X8	
16	HB1-1784-000		1	BRUSH, STATIC DISCHARGE	
17	HF5-0362-030		1	WHITE SHEET UNIT	
18	HS5-2129-000		1	SPRING, WHITE SHEET	
19	HB1-3257-000		1	STOPPER, OPERATION PANEL	
20	HB1-2875-000		1	SHEET, DOCUMENT STOP	
21	HB1-2860-030		1	COVER, ADF, UPPER	
22	XB4-7300-807		2	SCREW, TAP TIGHT, BINDING HEAD	

FIGURE 9 ADF LOWER



\* = Lubrication  
See page 4-1

FIGURE & KEY No.	PART No.	RANK	QTY	DESCRIPTION	REMARKS
9 - 1	HB1-3034-000		1	ROLLER, SEPARATION	
2	HB1-1779-000		1	SPACER	
3	HS5-2077-000		1	SPRING, CLUTCH	
4	HS5-0152-020		1	GEAR, Z40B	
5	HB1-2881-000		1	SHAFT, SEPARATION ROLLER	
6	HH2-2813-020		1	CABLE, CS	
7	HH7-2285-000		1	CONTACT SENSOR UNIT	
8	XB4-7300-807		4	SCREW, TAP TIGHT, BINDING HEAD	
9	HB1-3037-000	N	1	PLATE, CONTACT SENSOR	
10	XB4-7260-607		1	SCREW, TAP TIGHT, BINDING HEAD	
11	HF5-0375-000		2	LOCK, OPERATION PANEL	
12	HB1-3033-000		1	ROLLER, DOCUMENT FEED	
13	HS5-0253-030		1	GEAR, Z21/28B	
14	HS5-0155-000		1	GEAR, Z21D	
15	HF5-0328-000		1	ROLLER, DOCUMENT EJECT	
16	HS5-1070-030		2	BUSHING	
17	HS5-1069-030		1	BUSHING	
18	HB1-3031-000		1	FRAME, ADF LOWER	
19	HH2-2765-000		1	WIRE, GROUNDING	
20	HH7-2290-000		1	MOTOR, DOCUMENT FEED	
21	XB1-2300-407		3	SCREW, BH3X4 (S)	
22	HB1-3036-000		1	PLATE, GROUNDING	
23	HB1-3038-000		1	PLATE, DOCUMENT FEED MOTOR	
24	HS5-0252-030		1	GEAR, Z21/Z54	
25	HS5-0250-030		1	GEAR, Z82D	
26	HS5-0251-030		1	GEAR, Z59D	
27	XB4-7301-007		2	SCREW, TAP TIGHT BH3X10	

FIGURE 10 SCANNER ASS'Y

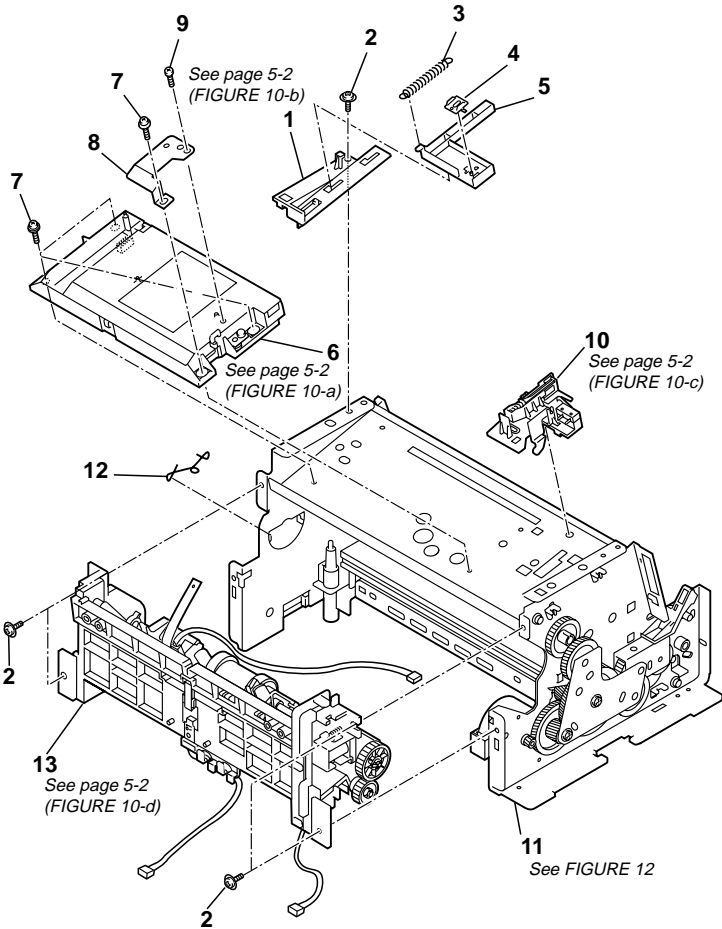

FIGURE & KEY No.	PART No.	RANK	QTY	DESCRIPTION
10 - 1	HB1-3016-000		1	BASE, ACTUATER
2	XA9-0724-000		5	SCREW, M3X8
3	HS5-2140-000		1	SPRING, ACTUATER
4	HB1-3018-000		1	STOPPER, TAPE
5	HB1-3017-030		1	ACTUATER, TONER SENSOR
6	RG9-1281-000		1	SCANNER ASS'Y
7	XB6-7300-807		4	SCREW, TP, M3X8
8	HB1-3418-000		1	SPRING, GROUNDING
9	XB4-7300-809		1	SCREW, TAP, BINDING HEAD, M3X8
10	RG5-3453-000		1	SWITCH LEVER ASS'Y
11	NPN		1	FRAME
12	RB1-7223-000		1	SPRING, GROUNDING
13	NPN		1	PAPER FEED UNIT



**FIGURE 11 FIXING SECTION 1**

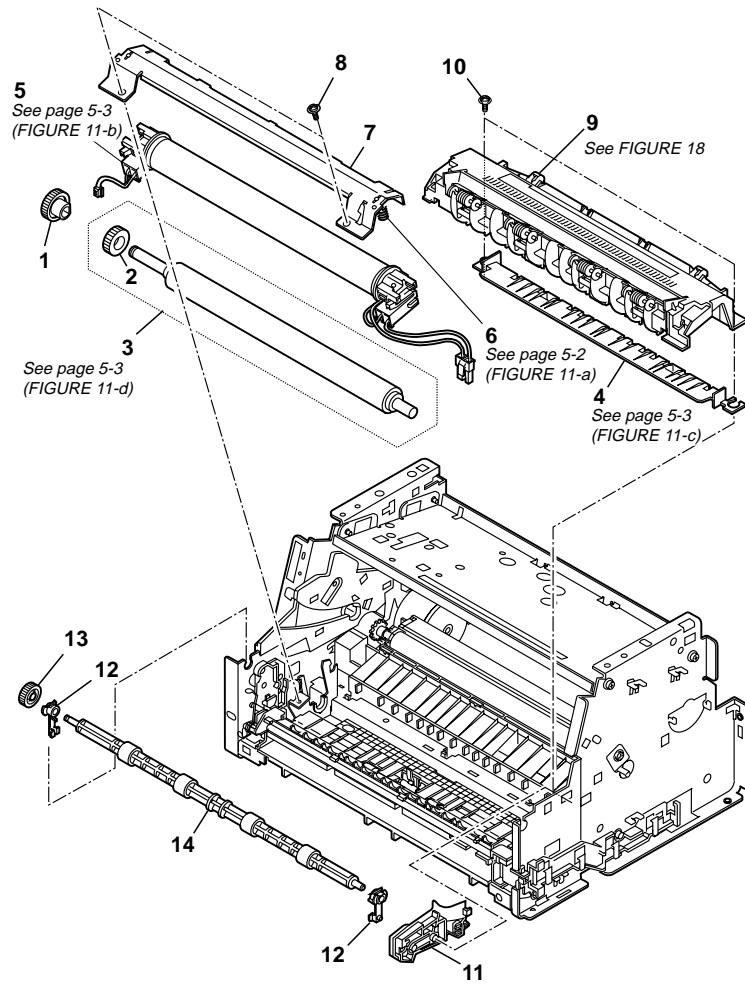

FIGURE & KEY No.	PART No.	RANK	QTY	DESCRIPTION	REMARKS
11-1	RS5-0796-000		1	GEAR, 27T	
2	RB2-1668-000		1	RUBBER, CONTINUITY	
3	RF5-2364-000		1	ROLLER, PRESSURE	
4	RB1-7247-000		1	GUIDE, PAPER	
5	RG5-3463-000		1	FIXING ASS'Y	
6	RS5-2508-000		2	SPRING, COMPRESSION	
7	RF5-1517-020	N	1	PLATE, PRESSURE	
8	XB6-7300-807		2	SCREW, TP, M3X8	
9	RG5-3474-020		1	DELIVERY ASS'Y	
10	XA9-0724-000		2	SCREW, M3X8	
11	RB1-7341-020		1	GUIDE, SUB, CARTRIDGE, RIGHT	
12	RB1-7288-020		2	BUSHING	
13	RS5-0797-000		1	GEAR, 18T	
14	RF5-2367-000		1	ROLLER, FEEDER	

FIGURE 12 DRIVE GEARS

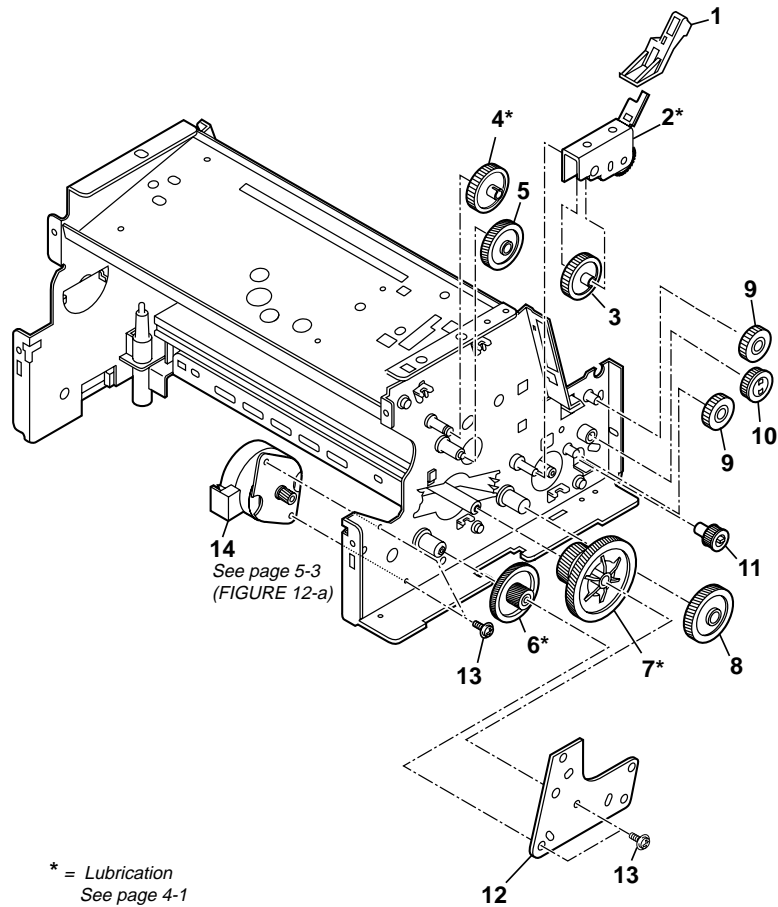

FIGURE & KEY No.	PART No.	RANK	QTY	DESCRIPTION	REMARKS
12 - 1	RB1-8170-000		1	LEVER, RELEASE, D	
2	RF5-1513-000		1	ARM, SWING	
3	RS5-0791-000		1	GEAR, 36T	
4	RS5-0789-000		1	GEAR, 37T	
5	RS5-0799-000		1	GEAR, 51T/17T	
6	RS6-0380-000		1	GEAR, 23T/98T	
7	RS5-0788-000		1	GEAR, 32T/93T	
8	RS5-0790-000		1	GEAR, 54T/19T	
9	RS5-0793-000		2	GEAR, 22T	
10	RS5-0794-000		1	GEAR, 24T	
11	RS5-0798-000		1	GEAR, 15T	
12	RB2-1632-000	N	1	PLATE, GEAR SUPPORT	
13	XA9-0267-000		4	SCREW, TP, M3X6	
14	RH7-1320-000		1	MOTOR, DC 12V 24W	

**FIGURE 13 FIXING SECTION 2**

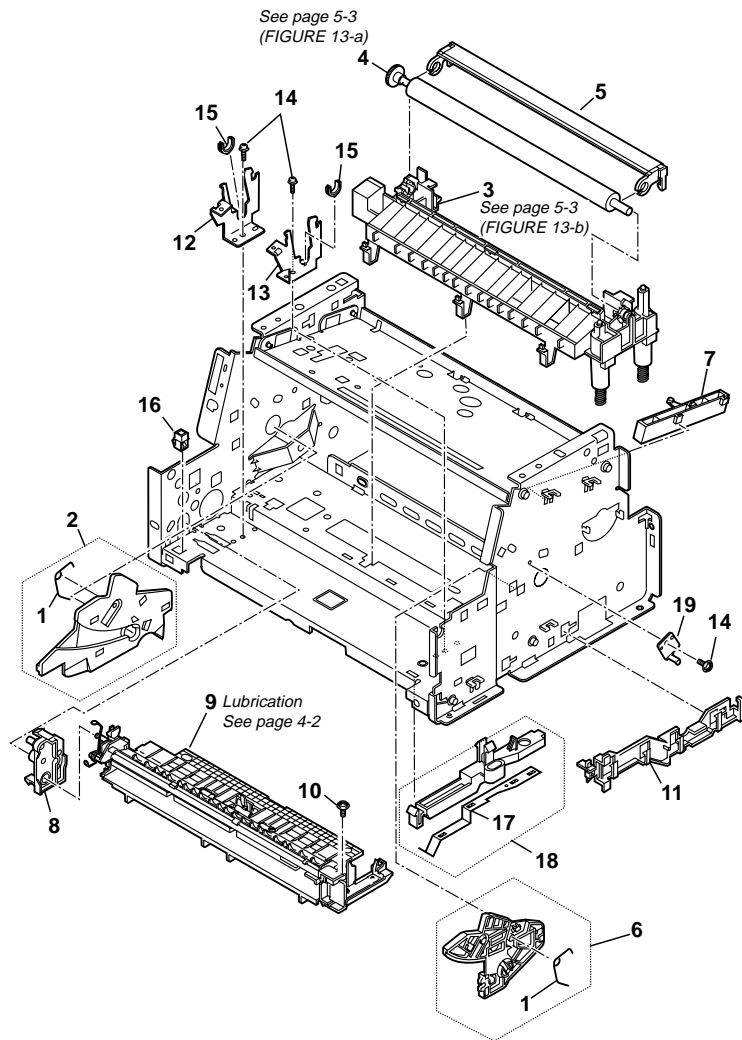

FIGURE & KEY No.	PART No.	RANK	QTY	DESCRIPTION
13- 1	RS5-2506-000		2	SPRING, TORSION
2	RF5-1514-020		1	GUIDE, CARTRIDGE,LEFT
3	RG5-3452-000		1	TRANSFER BLOCK ASS'Y
4	RF5-1534-000		1	ROLLER, TRANSFER
5	RF5-2358-000		1	GUIDE, TRANSFER
6	RF5-1515-020		1	GUIDE, CARTRIDGE
7	HB1-3019-000		1	STOPPER, CARTRIDGE
8	RB1-7107-000		1	HOLDER, GEAR
9	RG5-3475-040		1	SEPARATION GUIDE ASS'Y
10	XA9-0724-000		1	SCREW, M3X8
11	RB1-7130-020		1	GUIDE, CABLE
12	RB1-7255-000	N	1	SIDE PLATE, LEFT
13	RB1-7256-000	N	1	SIDE PLATE, RIGHT
14	XA9-0724-000		3	SCREW, M3X8
15	RB1-7246-000		2	BUSHING
16	VS1-5057-002		1	CONNECTOR, 2P
17	RB1-7238-000		1	SPRING, LEAF
18	RF5-1533-000		1	PLATE, COMMUNITY
19	RB1-7129-000		1	SPRING, GROUNDING

FIGURE 14 PAPER FEED SECTION

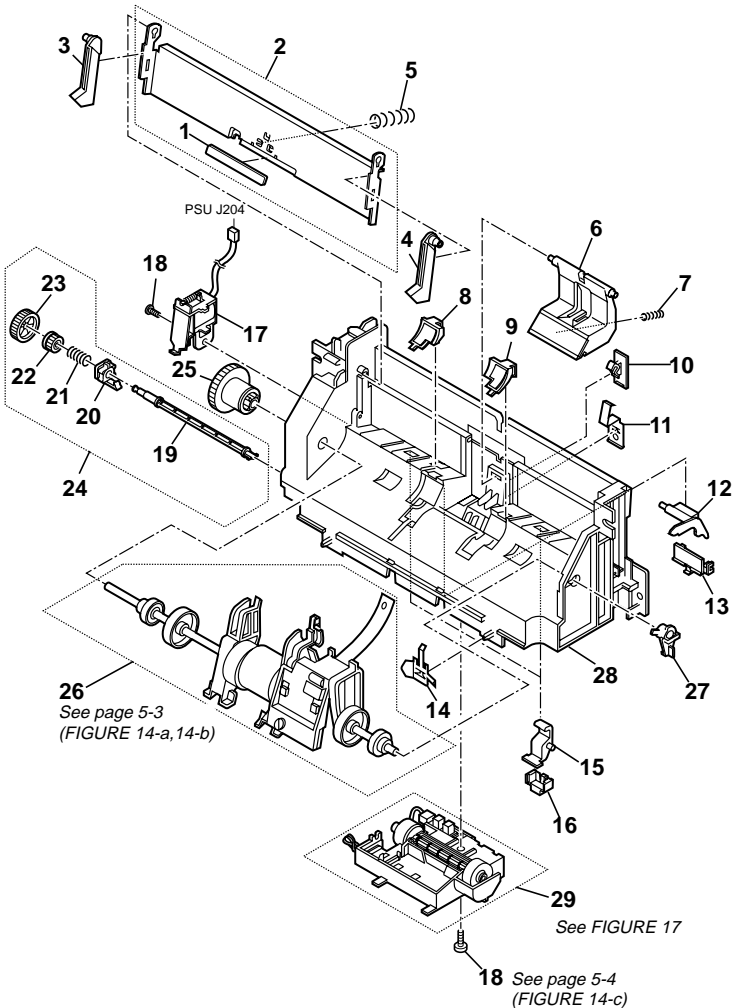

FIGURE & KEY No.	PART No.	RANK	QTY	DESCRIPTION	REMARKS
14- 1	RB2-1706-000		1	SHEET, SEPARATION	
2	RF5-2372-000		1	PLATE, MIDDLE	
3	RB1-7185-000		1	ARM, PLATE, LEFT	
4	RB1-7186-000		1	ARM, PLATE, RIGHT	
5	RS5-2501-000		1	SPRING, COMPRESSION	
6	RB1-7181-000		1	ARM, SEPARATION	
7	RS5-2502-000		1	SPRING, COMPRESSION	
8	RF5-1492-000		1	PAD, LEFT	
9	RF5-1493-000		1	PAD, RIGHT	
10	RB1-7206-000		1	HOLDER, ARM	
11	RB1-7199-000		1	SPRING, GROUNDING	
12	RB1-7182-000		1	LEVER, SENSOR	
13	RB1-7183-000		1	HOLDER, LEVER	
14	RB1-7172-000		1	SPRING, GROUNDING	
15	RB1-7219-000		2	STOPPER	
16	RB1-7220-000		2	HOLDER, STOPPER	
17	RH7-5139-030		1	SOLENOID	
18	XB4-7401-007		2	SCREW, PAN HEAD SELF-TAPPING	
19	RB1-7221-000		1	SHAFT, DRIVE	
20	RB1-7222-000		1	BUSHING	
21	RS5-2510-000		1	SPRING, COMPRESSION	
22	RB1-7224-000		1	RATCHET	
23	RS5-0786-000		1	GEAR, 24T	
24	RG5-1947-000		1	FEEDER DRIVE ASS'Y	
25	RB1-7197-020		1	CLUTCH	
26	HG5-1288-000		1	PICKUP ROLLER ASS'Y	
27	RB1-7184-000		1	BUSHING	
28	RB1-7177-000	N	1	FRAME, PAPER FEED	
29	RG5-3485-030		1	FEEDER ASS'Y	

**FIGURE 15 PICK-UP ROLLER ASS'Y**

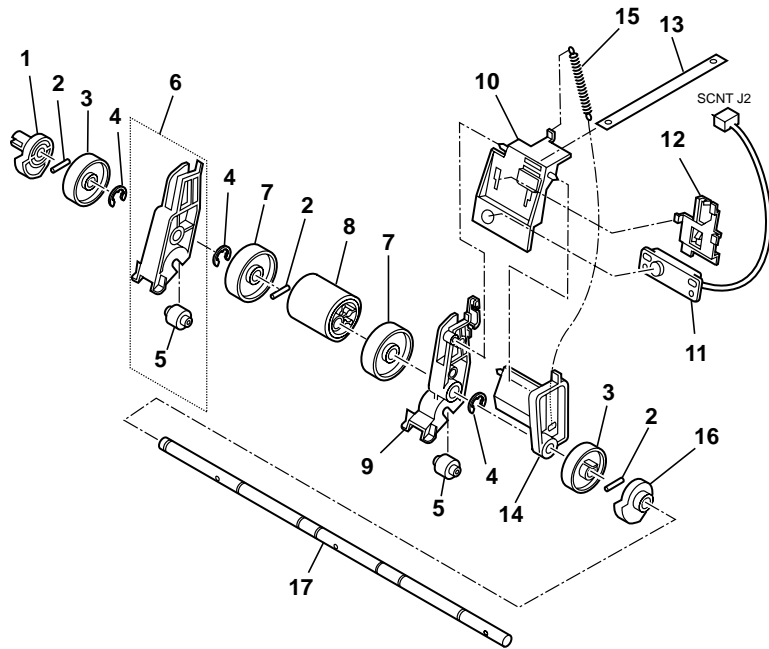

FIGURE & KEY No.	PART No.	RANK	QTY	DESCRIPTION	REMARKS
15 - 1	RB1-7193-000		1	CAM, LEFT	
2	XD9-0159-000		3	PIN, DOWEL	
3	RB2-1703-000		2	ROLLER, SUB	
4	XD9-0131-000		4	RING,E	
5	RB2-1701-000		2	ROLLER, FEED	
6	RG5-3492-000		1	FEED ROLLER ASS'Y, LEFT	
7	RB2-1633-000		2	ROLLER, SUB	
8	RB2-1634-000		1	ROLLER, PAPER PICK-UP	
9	HB1-3013-000		1	HOLDER, ROLLER	
10	HB1-3011-000		1	HOLDER, TONER SENSOR	
11	HH7-2291-000		1	TONER SENSOR ASS'Y	
12	HB1-3012-000		1	SUPPORTER, TONER SENSOR	
13	HB1-3015-000		1	BELT, TONER SENSOR	
14	HB1-3014-000		1	SUB HOLDER, ROLLER	
15	HS5-2139-000		1	SPRING, TONER SENSOR	
16	RB1-7194-000		1	CAM, RIGHT	
17	RB2-1707-000	N	1	SHAFT, PAPER PICK-UP	



**FIGURE 17 FEEDER ASS'Y**

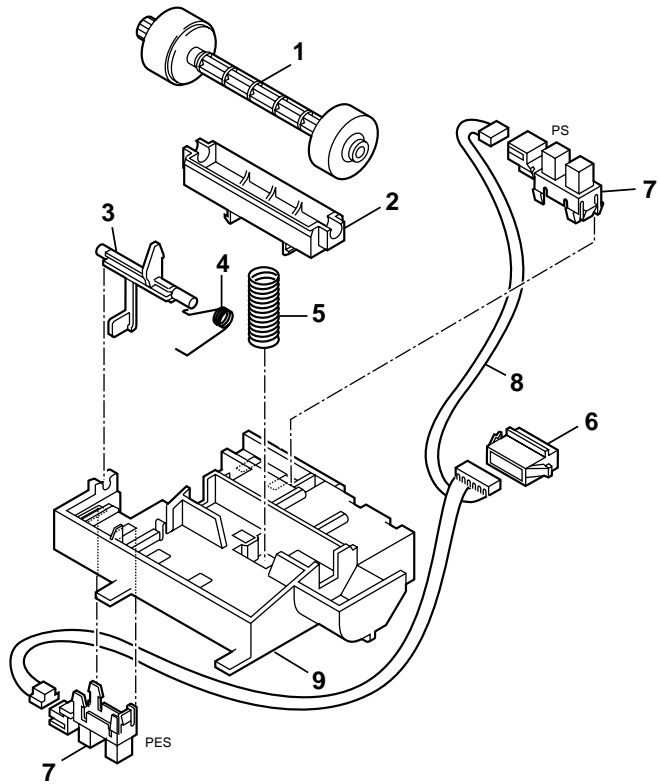

FIGURE & KEY No.	PART No.	RANK	QTY	DESCRIPTION	REMARKS
17 - 1	RB2-1699-000			ROLLER	
2	RB1-7203-000			ARM, PRESSURE	
3	RB2-1700-030			LEVER, REGISTRATION SENSOR	
4	RB1-7205-000			SPRING, TORSION	
5	RS5-2503-000			SPRING, COMPRESSION	
6	VS1-5057-006			CONNECTOR, 6P	
7	WG8-5362-000			IC, TLP1241 PHOTO INTERRUPTER	
8	RG9-1946-000			PICK-UP SENSOR CABLE 2	
9	RB1-7200-030			HOLDER	









# 3. TOOL

FIGURE 21 TOOLS

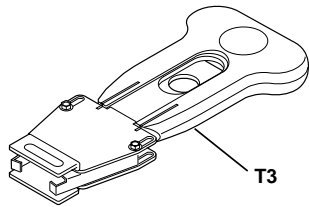
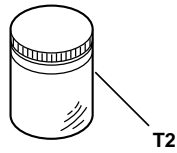
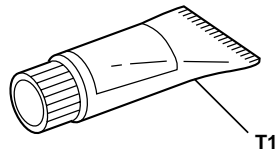

FIGURE & KEY No.	PART No.	RANK	QTY	DESCRIPTION	REMARKS
21 - T1	HY9-0007-000		1	LUBE, MOLYKOTE EM-50L	
T2	CK-8006-000		1	ELECTRICITY GREASE (IF-20)	
T3	HY9-0022-000		1	IC-REMOVING TOOL (24-64P)	



## 4. LUBRICATIONS

### 4.1 Locations

Some parts are lubricated with grease to ensure smooth operation and to increase conductivity. If lubricated parts are replaced or grease is removed, grease must be reapplied.

#### 4.1.1 DOCUMENT FEED ROLLER

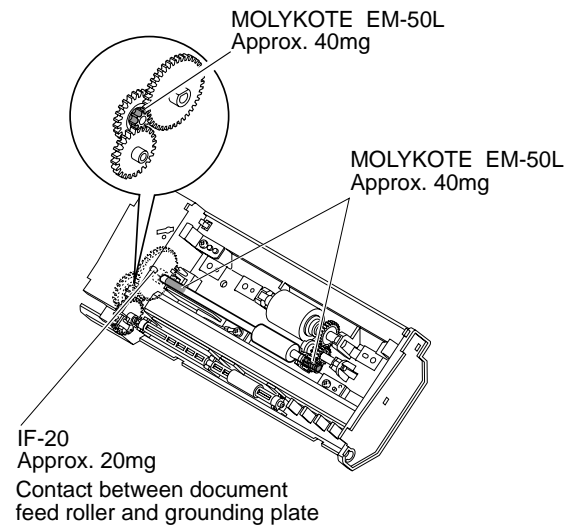

See Fig.9 for the assembly

#### 4.1.2 DRIVE GEARS

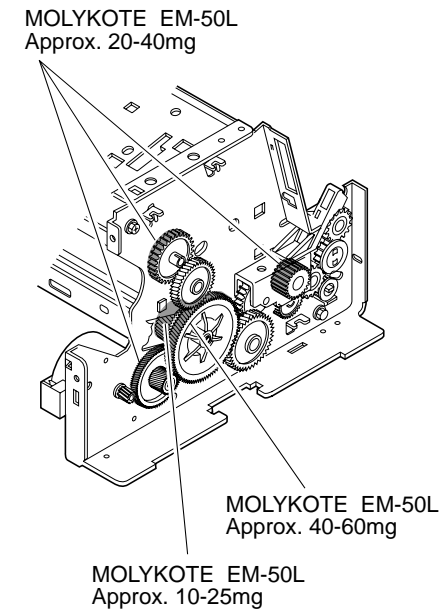

See Fig.12 for the assembly

4.1.3 PRESSURE ROLLER & SEPARATION GUIDE ASS'Y

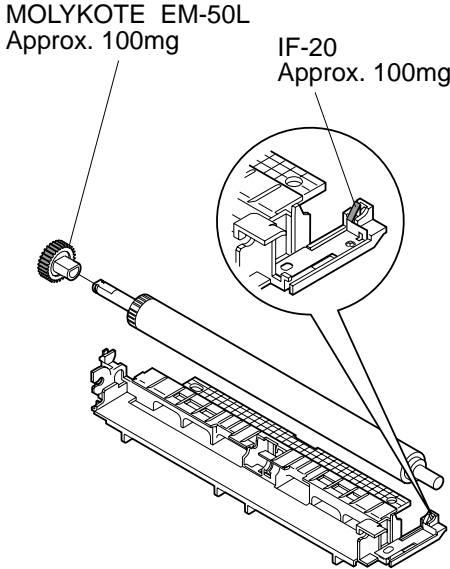

See Fig.13 for the assembly

# 5. GUIDE TO REPLACEMENT

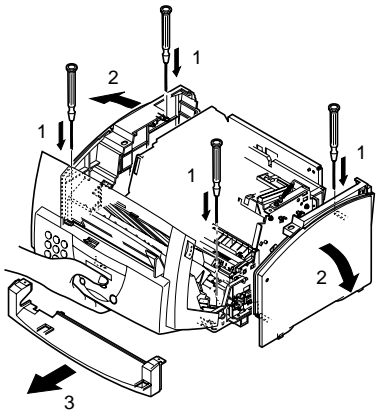
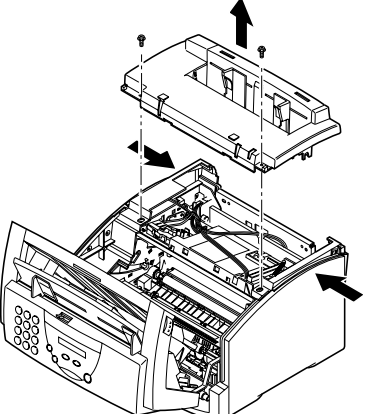
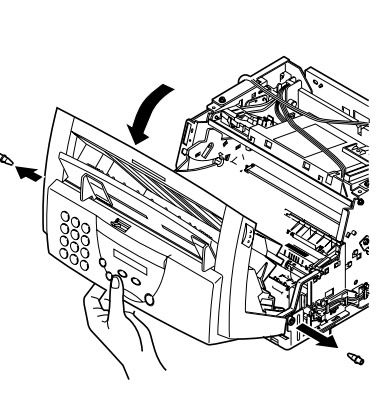
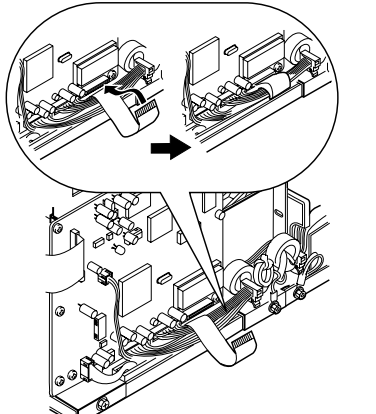
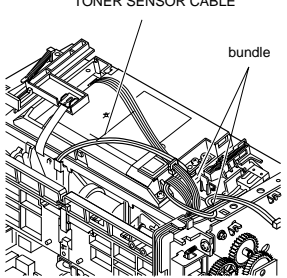
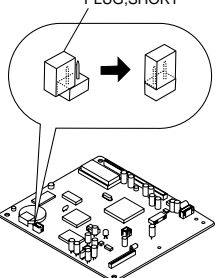
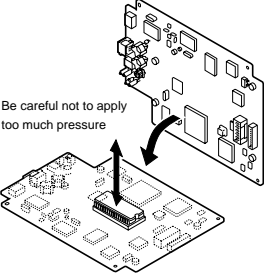
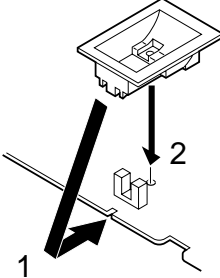
<p><b>FIGURE 2-a</b></p>	<p>See Page 2-2</p>	<p><b>FIGURE 2-b</b></p>	<p>See Page 2-2</p>	<p><b>FIGURE 3-a</b></p>	<p>See Page 2-3</p>	<p><b>FIGURE 3-b</b></p>	<p>See Page 2-3</p>
 <p>To remove the left and right side covers, use a fine screwdriver or your finger to unhook the retaining clips.</p>	 <p>While pressing either the left or right side cover in the direction shown, lift off the upper cover.</p>	 <p>When removing the READING ASS'Y, use one hand to support, the READING ASS'Y while removing the TAPER PIN.</p>	 <p>Use a FLAT CABLE to gather and contain the cables coming from the READ ASS'Y.</p>				
<p><b>FIGURE 4-a</b></p>	<p>See Page 2-4</p>	<p><b>FIGURE 4-b</b></p>	<p>See Page 2-4</p>	<p><b>FIGURE 4-c</b></p>	<p>See Page 2-4</p>	<p><b>FIGURE 5-a</b></p>	<p>See Page 2-5</p>
 <p>Route the TONER SENSOR CABLE as shown in the figure to anchor the LASER CABLE and DOOR SENSOR CABLE.</p>	 <p>The service part version of the SCNT board has a SHORT PLUG on one of the pins. When replacing the SCNT board, cover both pins with the plug. If both pins of the SCNT board service part are already by the plug, DO NOT INSTALL THE PART; the backup battery may be significantly depleted. When installing, be careful to avoid electrostatic damage to board components.</p>	 <p>When exchanging the ROM on the G4 board, please work on a table or stand which has an electrically resistant rubber mat. When removing the ROM, first remove the G4 board from the machine, and then use the special tool (part No.HY9-0022-000) to remove the ROM. Also, when attaching the ROM to the G4 board, if the ROM is pressed into place from the top too firmly, the patterns or elements on the board may be damaged, so please be careful.</p>	 <p>To attach the WATER PROOF COVER to the PCNT board, slide it into position (1) and press down to secure (2).</p>				

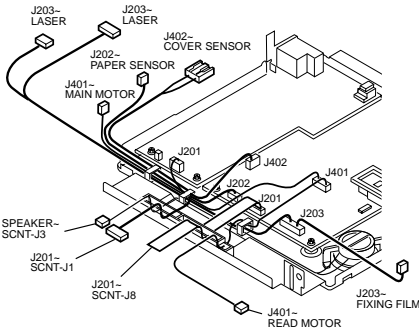
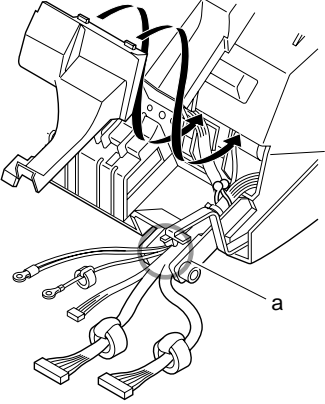
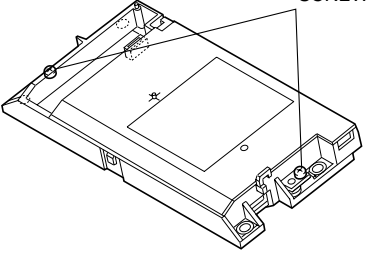
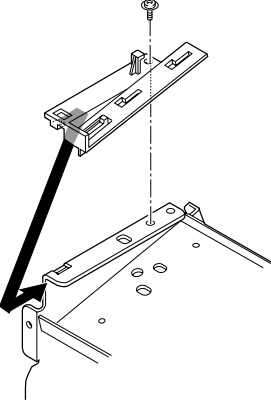
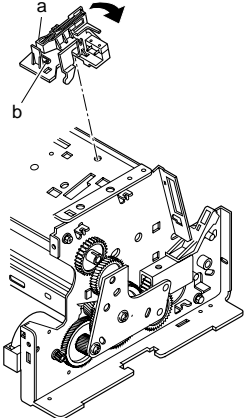
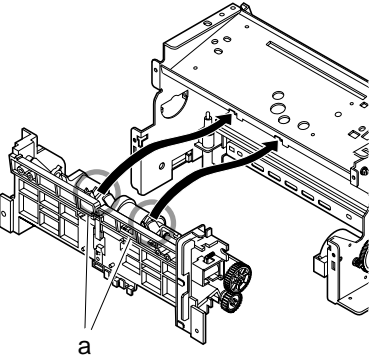
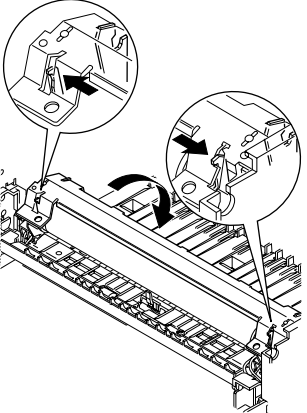
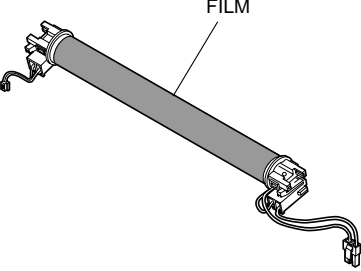
<p><b>FIGURE 5-b</b></p>	<p>See Page 2-5</p>	<p><b>FIGURE 6-a</b></p>	<p>See Page 2-6</p>	<p><b>FIGURE 10-a</b></p>	<p>See Page 2-10</p>	<p><b>FIGURE 10-b</b></p>	<p>See Page 2-10</p>
 <p>Route the cables on the PCNT and PSU boards as shown in the figure.</p>		 <p>Attach the CABLE COVER by hooking the projections into the slots as shown by the arrows. Be careful not to pinch the cables (a).</p>		 <p>Do not loosen or remove the two black screws on the SCANNER ASS'Y.</p>		 <p>Attach the ACTUATOR BASE retaining clip to the frame as shown by the arrow.</p>	
<p><b>FIGURE 10-c</b></p>	<p>See Page 2-10</p>	<p><b>FIGURE 10-d</b></p>	<p>See Page 2-10</p>	<p><b>FIGURE 11-a</b></p>	<p>See Page 2-11</p>	<p><b>FIGURE 11-b</b></p>	<p>See Page 2-11</p>
 <p>To attach the SWITCH LEVER ASS'Y: with portion (a) lifted up, and while continuing to press upward on pin (b), rotate the ass'y in the arrow's direction.</p>		 <p>After attaching the PAPER FEED UNIT to the frame, hook portions (a) into the slots as shown by the arrows.</p>		 <p>When removing the PRESSURE PLATE, use a fine screwdriver to press the clips outward and unhook them.</p>		 <p>Be careful not to touch the film on the FIXING ASS'Y with your hands.</p>	

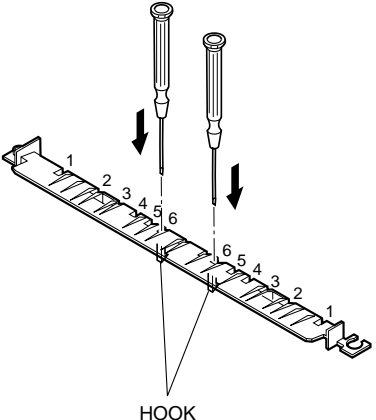
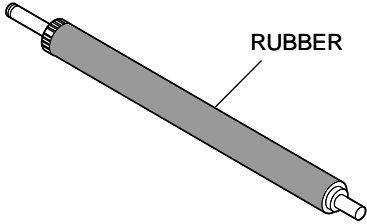
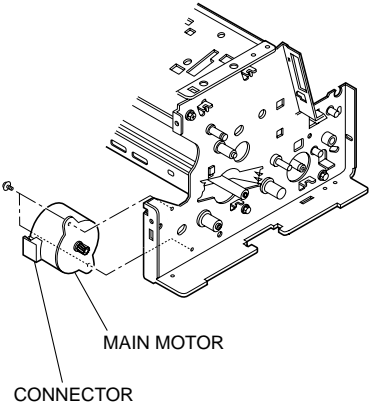
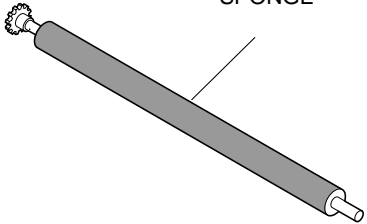
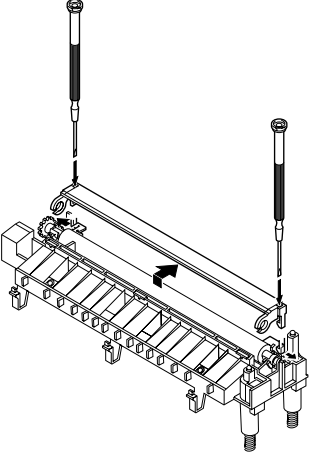
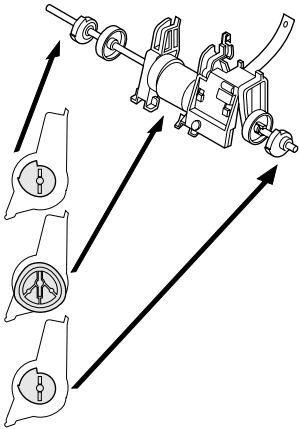
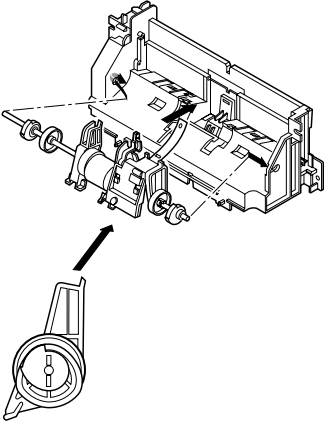
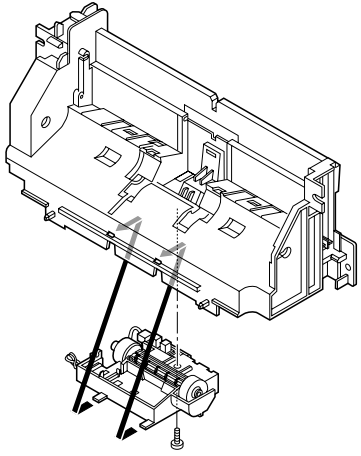

<p><b>FIGURE 11-c</b></p>	<p>See Page 2-11</p>	<p><b>FIGURE 11-d</b></p>	<p>See Page 2-11</p>	<p><b>FIGURE 12-a</b></p>	<p>See Page 2-12</p>	<p><b>FIGURE 13-a</b></p>	<p>See Page 2-13</p>
 <p>HOOK</p> <p>Insert a fine screwdriver into the sixth holes from both left and right ends to unhook the retaining clips.</p>	 <p>RUBBER</p> <p>Do not touch the rubber portion of the PRESSURE ROLLER with your hands.</p>	 <p>MAIN MOTOR</p> <p>CONNECTOR</p> <p>When attaching the MAIN MOTOR, position it as shown in the figure.</p>	 <p>SPONGE</p> <p>Do not touch the sponge portion of the TRANSFER ROLLER with your hands.</p>				
<p><b>FIGURE 13-b</b></p>	<p>See Page 2-13</p>	<p><b>FIGURE 14-a</b></p>	<p>See Page 2-14</p>	<p><b>FIGURE 14-b</b></p>	<p>See Page 2-14</p>	<p><b>FIGURE 14-c</b></p>	<p>See Page 2-14</p>
 <p>When removing the TRANSFER GUIDE, use a fine screwdriver to unhook the retaining clips.</p>	 <p>When assembling the PICKUP ROLLER ASS'Y, be careful that the cams and roller are correctly aligned.</p>	 <p>When attaching the PICKUP ROLLER ASS'Y, be sure it is faced in the direction shown in the figure.</p>	 <p>Slide the projections on the FEEDER ASS'Y into the slots on the PAPER FEED FRAME.</p>				

# 6. NUMERICAL INDEX

PART NUMBER	FIGURE & KEY NO.	DESCRIPTION	PART NUMBER	FIGURE & KEY NO.	DESCRIPTION	PART NUMBER	FIGURE & KEY NO.	DESCRIPTION	PART NUMBER	FIGURE & KEY NO.	DESCRIPTION
CK-8006-000	21 - T2	ELECTRICITY GREASE (IF-20)	HB1-3023-000	5 - 16	HOLDER, SPEAKER	HH9-5332-000	5 - 2	POWER SUPPLY UNIT	RB1-7223-000	10 - 12	SPRING, GROUNDING
HB1-1230-000	2 - 20	PAPER OUT PUT EXTENSION	HB1-3024-040	5 - 22	FOOT, LEFT	HH4-3211-000	4 - 19	IC, LH538N3D, MASK-ROM	RB1-7224-000	14 - 22	RATCHET
HB1-1779-000	9 - 2	SPACER	HB1-3025-040	5 - 23	FOOT, RIGHT	HH4-3213-000	4 - 20	IC, UPD23C8000XCZ-224, MASK-ROM	RB1-7236-000	19 - 8	PIN, CONTACT
HB1-1784-000	8 - 16	BRUSH, STATIC DISCHARGE	HB1-3026-050	5 - 20	RAIL, OUTPUT TRAY	HH7-2285-000	9 - 7	CONTACT SENSOR UNIT	RB1-7237-000	19 - 6	PIN, CONTACT
HB1-1870-000	6 - 10	SHEET	HB1-3027-030	4 - 4	HOLDER, SCNT BOARD	HH7-2287-000	5 - 15	SPEAKER UNIT	RB1-7238-000	13 - 17	SPRING, LEAF
HB1-2860-030	8 - 21	COVER, ADF, UPPER	HB1-3028-000	4 - 12	SHEET, CORE GARD	HH7-2290-000	9 - 20	MOTOR, DOCUMENT FEED	RB1-7246-000	13 - 15	BUSHING
HB1-2861-000	8 - 8	ARM, DETECTION (DES)	HB1-3031-000	9 - 18	FRAME,ADF LOWER	HH7-2291-000	15 - 11	TONER SENSOR ASS'Y	RB1-7247-000	11 - 4	GUIDE, PAPER
HB1-2862-000	8 - 10	ARM, DETECTION (DS)	HB1-3032-000	7 - 1	COVER, DOCUMENT GUIDE, LOWER	HH7-2303-000	8 - 1	OPERATION PANEL ASS'Y	RB1-7255-000	13 - 12	SIDE PLATE, LEFT
HB1-2863-000	8 - 13	STOPPER, DOCUMENT	HB1-3033-000	9 - 12	ROLLER, DOCUMENT FEED	HS5-0152-020	9 - 4	GEAR, Z40B	RB1-7256-000	13 - 13	SIDE PLATE, RIGHT
HB1-2864-000	8 - 5	ROLLER, BACK UP	HB1-3034-000	9 - 1	ROLLER, SEPARATION	HS5-0155-000	9 - 14	GEAR, Z21D	RB1-7270-000	5 - 12	CUSHION
HB1-2865-000	8 - 7	SHAFT, BACK UP ROLLER	HB1-3035-000	16 - 4	PAD, SEPARATION	HS5-0238-020	7 - 9	GEAR, Z16	RB1-7277-000	20 - 4	SPRING, TORSION
HB1-2866-000	8 - 9	PLATE, PRESSURE	HB1-3036-000	9 - 22	PLATE, GROUNDING	HS5-0250-030	9 - 25	GEAR, Z82D	RB1-7284-020	18 - 5	ROLLER, FACE DOWN
HB1-2871-030	16 - 3	PLATE, PRESSURE	HB1-3037-000	9 - 9	PLATE, CONTACT SENSOR	HS5-0251-030	9 - 26	GEAR, Z59D	RB1-7286-000	18 - 6	SPRING, WIRE
HB1-2873-030	16 - 2	HOLDER, SEPARATION GUIDE	HB1-3038-000	9 - 23	PLATE, DOCUMENT FEED MOTOR	HS5-0252-030	9 - 24	GEAR, Z21Z54	RB1-7287-000	18 - 8	SPRING, WIRE
HB1-2875-000	8 - 20	SHEET, DOCUMENT STOP	HB1-3041-000	8 - 14	LEVER, DOCUMENT RELEASE	HS5-0253-030	9 - 13	GEAR, Z2128B	RB1-7288-020	11 - 12	BUSHING
HB1-2881-000	9 - 5	SHAFT, SEPARATION ROLLER	HB1-3042-000	4 - 2	COVER, FIXING SECTION, LEFT	HS5-0254-000	2 - 8	GEAR, Z16	RB1-7293-020	20 - 1	LEVER, SENSOR
HB1-2883-000	7 - 7	SLIDER, RACK	HB1-3043-000	4 - 1	COVER, FIXING SECTION, RIGHT	HS5-1069-030	9 - 17	BUSHING	RB1-7294-000	20 - 2	SPRING, TORSION
HB1-2885-000	16 - 5	HOLDER, SEPARATION	HB1-3044-000	6 - 14	SHEET, PAPER EJECT (L)	HS5-1070-030	9 - 16	BUSHING	RB1-7334-000	18 - 9	GUIDE, JAMMED PAPER REMOVAL
HB1-2980-000	2 - 1	COVER, UPPER	HB1-3045-000	6 - 15	SHEET, PAPER EJECT (R)	HS5-2077-000	9 - 3	SPRING, CLUTCH	RB1-7341-020	11 - 11	GUIDE, SUB, CARTRIDGE, RIGHT
HB1-2982-040	2 - 16	COVER, RIGHT	HB1-3049-000	2 - 13	SUPPORT, STOPPER	HS5-2078-000	8 - 3	SPRING	RB1-8170-000	12 - 1	LEVER, RELEASE, D
HB1-2984-030	2 - 17	COVER, FRONT	HB1-3105-000	6 - 4	COVER, CABLE	HS5-2079-000	16 - 1	SPRING, SEPARATION GUIDE	RB2-1632-000	12 - 12	PLATE, GEAR SUPPORT
HB1-2985-000	4 - 3	LEVER, SWITCHING	HB1-3109-020	6 - 8	STOPPER, CRG	HS5-2129-000	8 - 18	SPRING, WHITE SHEET	RB2-1633-000	15 - 7	ROLLER, SUB
HB1-2987-000	2 - 19	TRAY, PAPER OUTPUT	HB1-3210-000	1 - 4	LABEL, CAUTION	HS5-2130-000	7 - 8	SPRING, SLIDER	RB2-1634-000	15 - 8	ROLLER, PAPER PICK-UP
HB1-2988-060	1 - 2	TRAY, SUPPORT	HB1-3211-000	2 - 5	SHEET, TRAY	HS5-2139-000	15 - 15	SPRING, TONER SENSOR	RB2-1655-000	19 - 2	BUSHING
HB1-2989-000	1 - 1	TRAY, PAPER REST	HB1-3212-000	5 - 21	FOOT, RUBBER	HS5-2140-000	10 - 3	SPRING, ACTUATER	RB2-1656-000	19 - 4	BUSHING
HB1-2991-000	3 - 1	PIN, TAPER	HB1-3257-000	8 - 19	STOPPER, OPERATION PANEL	HS5-2141-020	2 - 7	SPRING, SLIDER	RB2-1657-000	19 - 1	ELIMINATOR, STATIC CHARGE
HB1-2992-000	2 - 12	COVER, ROM	HB1-3418-000	10 - 8	SPRING, GROUNDING	HS5-6023-030	8 - 6	ROLLER, BACK UP	RB2-1668-000	11 - 2	ROLLER, CONTINUITY
HB1-2995-080	7 - 4	COVER, CARTRIDGE	HB1-3688-000	2 - 11	COVER, LEFT	HS5-6042-000	8 - 12	ROLLER, DELIVERY, 2	RB2-1685-000	18 - 7	ROLLER, FACE UP
HB1-2996-000	6 - 2	AIR DUCT	HB1-3689-000	2 - 14	COVER, REAR	HY9-0007-000	21 - T1	LUBE, MOLYKOTE EM-50L	RB2-1686-000	18 - 2	FRAME
HB1-2997-000	6 - 3	GUIDE, FACE DOWN	HB1-3690-000	4 - 5	HOLDER, G4 BOARD	HY9-0022-000	21 - T3	IC-REMOVING TOOL (24-64P)	RB2-1687-000	20 - 5	GUIDE, SEPARATION
HB1-2998-030	7 - 5	GUIDE, DOCUMENT FEED, LEFT	HB1-3691-000	4 - 11	GUIDE, CABLE	RB1-7107-000	13 - 8	HOLDER, GEAR	RB2-1689-000	20 - 8	ROD, REINFORCEMENT
HB1-2999-030	7 - 6	GUIDE, DOCUMENT FEED, RIGHT	HB1-3692-000	4 - 15	SPACER, MODULAR JACK	RB1-7129-000	13 - 19	SPRING, GROUNDING	RB2-1690-000	20 - 7	BUSHING
HB1-3000-050	6 - 7	RELEASE BUTTON, LEFT	HF5-0328-000	9 - 15	ROLLER, DOCUMENT EJECT	RB1-7130-020	13 - 11	GUIDE, CABLE	RB2-1691-000	20 - 3	SPRING, LEAF
HB1-3001-000	6 - 1	AIR DUCT	HF5-0362-030	8 - 17	WHITE SHEET UNIT	RB1-7172-000	14 - 14	SPRING, GROUNDING	RB2-1699-000	17 - 1	ROLLER
HB1-3002-000	2 - 4	TRAY, AUTO PAPER FEED	HF5-0375-000	9 - 11	LOCK, OPERATION PANEL	RB1-7177-000	14 - 28	FRAME, PAPER FEED	RB2-1700-030	17 - 3	LEVER, REGISTRATION SENSOR
HB1-3003-000	2 - 2	GUIDE, AUTO PAPER FEED, LEFT	HG5-1288-000	14 - 26	PICKUP ROLLER ASS'Y	RB1-7181-000	14 - 6	ARM, SEPARATION	RB2-1701-000	15 - 5	ROLLER, FEED
HB1-3004-000	2 - 3	GUIDE, AUTO PAPER FEED, RIGHT	HG5-1292-020	2 - 10	AUTO PAPER FEED ASS'Y	RB1-7182-000	14 - 12	LEVER, SENSOR	RB2-1703-000	15 - 3	ROLLER, SUB
HB1-3008-000	2 - 6	RACK	HG5-1304-000	5 - 6	PCNT BOARD ASS'Y	RB1-7183-000	14 - 13	HOLDER, LEVER	RB2-1706-000	14 - 1	SHEET, SEPARATION
HB1-3009-050	6 - 6	RELEASE BUTTON, RIGHT	HG5-1308-000	8 - 2	SEPARATION GUIDE ASS'Y	RB1-7184-000	14 - 27	BUSHING	RB2-1707-000	15 - 17	SHAFT, PAPER PICK-UP
HB1-3010-030	6 - 5	SUPPORT, TRAY	HG5-1830-000	4 - 6	SCNT BOARD ASS'Y	RB1-7185-000	14 - 3	ARM, PLATE, LEFT	RF5-1492-000	14 - 8	PAD, LEFT
HB1-3011-000	15 - 10	HOLDER, TONER SENSOR	HG5-1831-000	4 - 7	G4 BOARD ASS'Y	RB1-7186-000	14 - 4	ARM, PLATE, RIGHT	RF5-1493-000	14 - 9	PAD, RIGHT
HB1-3012-000	15 - 12	SUPPORTER, TONER SENSOR	HH2-2758-000	5 - 10	FLAT CABLE	RB1-7193-000	15 - 1	CAM, LEFT	RF5-1513-000	12 - 2	ARM, SWING
HB1-3013-000	15 - 9	HOLDER, ROLLER	HH2-2759-000	5 - 11	CABLE ASSEMBLY	RB1-7194-000	15 - 16	CAM, RIGHT	RF5-1514-020	13 - 2	GUIDE, CARTRIDGE, LEFT
HB1-3014-000	15 - 14	SUB HOLDER, ROLLER	HH2-2760-000	5 - 9	CABLE WITH CONNECTOR, 6P	RB1-7197-020	14 - 25	CLUTCH	RF5-1515-020	13 - 6	GUIDE, CARTRIDGE
HB1-3015-000	15 - 13	BELT, TONER SENSOR	HH2-2762-000	5 - 5	CABLE ASSEMBLY	RB1-7199-000	14 - 11	SPRING, GROUNDING	RF5-1517-020	11 - 7	PLATE, PRESSURE
HB1-3016-000	10 - 1	BASE, ACTUATER	HH2-2765-000	9 - 19	WIRE, GROUNDING	RB1-7200-030	17 - 9	HOLDER	RF5-1533-000	13 - 18	PLATE, COMMUNITY
HB1-3017-030	10 - 5	ACTUATER, TONER SENSOR	HH2-2768-000	5 - 8	CABLE WITH CONNECTOR, 2P	RB1-7203-000	17 - 2	ARM, PRESSURE	RF5-1534-000	13 - 4	ROLLER, TRANSFER
HB1-3018-000	10 - 4	STOPPER, TAPE	HH2-2785-000	1 - 3	CORD, MODULAR	RB1-7205-000	17 - 4	SPRING, TORSION	RF5-2358-000	13 - 5	GUIDE, TRANSFER
HB1-3019-000	13 - 7	STOPPER, CARTRIDGE	HH2-2813-020	9 - 6	CABLE, CS	RB1-7206-000	14 - 10	HOLDER, ARM	RF5-2364-000	11 - 3	ROLLER, PRESSURE
HB1-3020-030	5 - 14	PLATE, BOTTOM	HH2-2814-000	8 - 11	WIRE, GROUNDING	RB1-7219-000	14 - 15	STOPPER	RF5-2367-000	11 - 14	ROLLER, FEEDER
HB1-3021-000	5 - 17	GUIDE, CABLE	HH2-2852-000	4 - 9	CABLE WITH CONNECTOR, 24P	RB1-7220-000	14 - 16	HOLDER, STOPPER	RF5-2368-000	20 - 6	ROLLER, FACE UP
HB1-3022-000	4 - 14	SPACER	HH2-2853-000	4 - 10	CABLE WITH CONNECTOR, 10P	RB1-7221-000	14 - 19	SHAFT, DRIVE	RF5-2372-000	14 - 2	PLATE, MIDDLE
	5 - 18		HH2-2870-000	5 - 7	CABLE ASSEMBLY	RB1-7222-000	14 - 20	BUSHING	RF5-2382-000	5 - 13	COVER, WATERPROOF

PART NUMBER	FIGURE & KEY NO.	DESCRIPTION	PART NUMBER	FIGURE & KEY NO.	DESCRIPTION
RG5-1947-000	14 - 24	FEEDER DRIVE ASS'Y		10 - 2	
RG5-3452-000	13 - 3	TRANSFER BLOCK ASS'Y		11 - 10	
RG5-3453-000	10 - 10	SWITCH LEVER ASS'Y		13 - 10	
RG5-3463-000	11 - 5	FIXING ASS'Y		13 - 14	
RG5-3474-020	11 - 9	DELIVERY ASS'Y	XA9-0863-000	5 - 4	SCREW, TAP M3X6
RG5-3475-040	13 - 9	SEPARATION GUIDE ASS'Y	XA9-0879-000	2 - 18	SCREW, RS M3X10
RG5-3476-030	20 - 9	FLAPPER	XB1-2300-407	9 - 21	SCREW, BH3X4 (S)
RG5-3478-000	18 - 4	SPUR ASS'Y	XB1-2300-807	4 - 17	SCREW, CROSS-RECESS, FCH
RG5-3479-000	18 - 3	SPUR ASS'Y	XB2-7300-607	5 - 3	SCREW, M3X6
RG5-3485-030	14 - 29	FEEDER ASS'Y	XB4-7260-607	9 - 10	SCREW, TAP TIGHT, BINDING HEAD
RG5-3492-000	15 - 6	FEED ROLLER ASS'Y, LEFT	XB4-7300-607	5 - 25	SCREW, TAP TIGHT, BINDING HEAD
RG9-1281-000	10 - 6	SCANNER ASS'Y	XB4-7300-807	8 - 22	SCREW, TAP TIGHT, BINDING HEAD
RG9-1946-000	17 - 8	PICK-UP SENSOR CABLE 2		9 - 8	
RH7-1320-000	12 - 14	MOTOR, DC 12V 24W	XB4-7300-809	6 - 12	SCREW, TAP, BINDING HEAD, M3X8
RH7-5139-030	14 - 17	SOLENOID		10 - 9	
RS5-0786-000	14 - 23	GEAR, 24T	XB4-7301-007	6 - 11	SCREW, TAP TIGHT BH3X10
RS5-0788-000	12 - 7	GEAR, 32T/93T		7 - 2	
RS5-0789-000	12 - 4	GEAR, 37T		8 - 4	
RS5-0790-000	12 - 8	GEAR, 54T/19T		9 - 27	
RS5-0791-000	12 - 3	GEAR, 36T	XB4-7301-409	6 - 13	SCREW, TAPPING M3X14
RS5-0793-000	12 - 9	GEAR, 22T	XB4-7401-007	4 - 16	SCREW, PAN HEAD SELF-TAPPING
RS5-0794-000	12 - 10	GEAR, 24T		14 - 18	
RS5-0796-000	11 - 1	GEAR, 27T	XB6-7300-807	2 - 15	SCREW, TP, M3X8
RS5-0797-000	11 - 13	GEAR, 18T		10 - 7	
RS5-0798-000	12 - 11	GEAR, 15T		11 - 8	
RS5-0799-000	12 - 5	GEAR, 51T/17T		15 - 4	RING,E
RS5-2501-000	14 - 5	SPRING, COMPRESSION	XD9-0131-000	15 - 4	
RS5-2502-000	14 - 7	SPRING, COMPRESSION	XD9-0159-000	15 - 2	PIN, DOWEL
RS5-2503-000	17 - 5	SPRING, COMPRESSION			
RS5-2504-000	19 - 3	SPRING, COMPRESSION			
RS5-2505-000	19 - 5	SPRING, COMPRESSION			
RS5-2506-000	13 - 1	SPRING, TORSION			
RS5-2508-000	11 - 6	SPRING, COMPRESSION			
RS5-2510-000	14 - 21	SPRING, COMPRESSION			
RS5-2512-000	19 - 7	SPRING, COMPRESSION			
RS5-8543-020	18 - 1	LABEL, "WARNING HIGH TEMP"			
RS6-0380-000	12 - 6	GEAR, 23T/98T			
VS1-5057-002	13 - 16	CONNECTOR, 2P			
VS1-5057-004	3 - 2	CONNECTOR, 4P			
VS1-5057-006	17 - 6	CONNECTOR, 6P			
VT2-0002-000	4 - 21	SPACER, SUPPORT			
WG8-5362-000	17 - 7	IC, TLP1241 PHOTO INTERRUPTER			
WS1-5397-000	4 - 8	PLUG, JUMPER			
WT2-0317-000	4 - 13	CLIP, CABLE			
	5 - 19				
WT2-5569-000	6 - 9	CLIP, CABLE			
XA9-0267-000	12 - 13	SCREW, TP, M3X6			
XA9-0476-000	2 - 9	SCREW, TP M3X8			
	7 - 10				
	8 - 15				
XA9-0724-000	3 - 3	SCREW, M3X8			
	4 - 18				
	5 - 24				



0299 SE 0.50-0  
0699 SE 0.30-0



Printed on paper that  
contains 60% reused paper.

# Canon